

DYNAMIC APERTURE MEASUREMENT AT THE VEPP-4M STORAGE RING

V. KISELEV, E. LEVICHEV, V. SAJAEV* and V. SMALUK

Budker Institute of Nuclear Physics, Novosibirsk 630090, Russia

(Received 10 November 1996; In final form 11 February 1997)

Dynamic aperture has been studied experimentally at the VEPP-4M electron–positron collider. A transverse bunch motion was excited by fast kickers. The beam intensity and the amplitude of the coherent oscillations were measured turn-by-turn by the BPM. In this paper the technique of determining the dynamic/physical aperture is described. Several methods of increasing the dynamic aperture are discussed. The results of computer simulation and simple model analytic prediction explaining the experimental data are presented.

Keywords: Particle dynamics; Storage rings; Dynamic aperture

1 INTRODUCTION

In Ref. 1 the results of the measurements of nonlinear phase trajectories and amplitude-dependent tune shift at VEPP-4M are discussed. Here we concentrate on the aperture limitation study due to the nonlinear magnetic field.

The measurements were performed at the injection energy of 1.8 GeV with the following beam parameters:² horizontal emittance $\epsilon_x = 35$ nm, betatron tunes $\nu_x = 8.620$ and $\nu_z = 7.572$, natural chromaticity $\xi_x = -13.6$ and $\xi_z = -20.6$, revolution period $\tau = 1.2$ μ s. Large contribution of the final focus quadrupoles to the natural chromaticity ($\simeq 50\%$ in the horizontal direction and $\simeq 60\%$ in the vertical direction) is compensated by the near-by sextupoles of SES2 and NES2 families (6 lenses). The residual chromaticity is corrected

* Corresponding author. E-mail: sajaev@tulip.inp.nsk.su.

in the arcs by 32 sextupole corrections distributed along the dipole magnets (*DS* and *FS* families). Besides, there is quadratic nonlinearity produced by the magnet pole shape and cubic nonlinearity generated by the octupole field correction winding incorporated inside the bending magnet coils.

The dynamic aperture is measured by the coherent beam motion excitation.^{3–5} Coherent betatron motion is excited by fast electro-magnet kickers in the horizontal or vertical planes. The electron/positron separator *TU9* is used as the horizontal kicker. It has a half-sine pulse with duration of 50 ns and maximum amplitude of 30 kV. In the vertical direction the beam is kicked by the positron beam inflector with the pulse of 150 ns duration and 25 kV amplitude.

To measure the beam displacement and the intensity of every revolution BPM *SRP3* in the turn-by-turn mode is used.⁶ There are four digitising channels equipped with fast 10-bit ADCs with 100 ns sampling time and 4K words memory. The ADCs are triggered by the *VEPP-4M* kicker magnet trigger. The measured BPM resolution (rms) in this mode for the beam current range of 1–5 mA equals $\simeq 70 \mu\text{m}$ for both directions.

The kicked beam displacement versus the turn number is shown in Figure 1. One can see that during several thousands of revolutions when the measurements are made, coherent and radiation damping are quite negligible for the horizontal motion. But for the vertical one, where strong electro-magnetic beam interaction with the inflector electrodes exists, fast damping is significant and should be taken into account when the vertical aperture is measured.

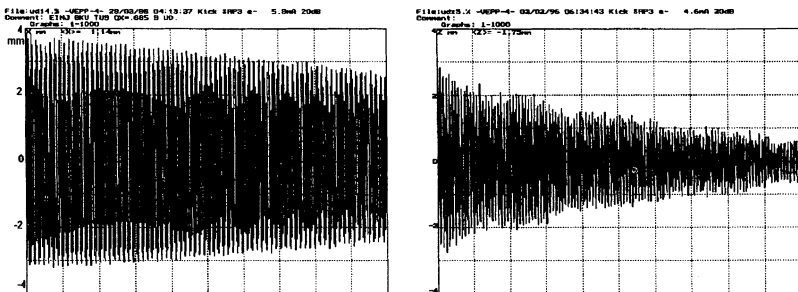

FIGURE 1 Horizontal (left) and vertical (right) beam displacement versus the turn number.

2 DYNAMIC APERTURE MEASUREMENT TECHNIQUE

The measurement of the coherent beam motion allows to determine dynamic or physical aperture as a displacement at which the beam intensity loss occurs – the same way it does in the computer tracking. But contrary to simulation where a single particle is tracked, in experiment we deal with a beam of a finite size and current. The latter can cause many effects (coherent and incoherent) which obscure the precise aperture measurement. Hence, the beam loss study has been carried out before performing a dynamic aperture measurement. We expected that the particles would be lost very fast outside the stable motion boundary because their amplitude grows exponentially when the nonlinear motion becomes unstable.

This study shows that:

1. When the kick amplitude is low, the BPM does not indicate the intensity reduction: all particles move inside the acceptance along the stable trajectories.
2. At some intermediate kick amplitude a long-term beam loss appears. The typical time interval for this loss is about 10 ms, and it occurs because of the particle distribution cut off by the aperture limitation. During this time many other effects (including damping) can take place, so it is difficult to extract the information about the dynamic aperture from this measurements.
3. And only starting with the high enough amplitude of the kick, a short time (20–50 turns) beam loss is observed (Figure 2). Only this loss corresponds to the dynamic aperture limitation because of the fast growth of the particle displacement outside the stable region.

The total intensity decreases include both long- and short-term parts but only the last one defines the aperture limitation unambiguously.

Apart from the beam intensity, the BPM also measures the position of the beam centre of mass. The initial amplitude of the coherent oscillations is computed for the first 30 turns to cancel all damping effects. For low amplitudes, the BPM coordinate reading X_p linearly depends on the kick voltage $X_p = KU$. However, when the fast beam loss is observed, this dependence drastically declines from the linear one (Figure 3). To explain this fact we have assumed that the beam centre of mass $X_p(U)$ differs from the actual kick amplitude X_0 just

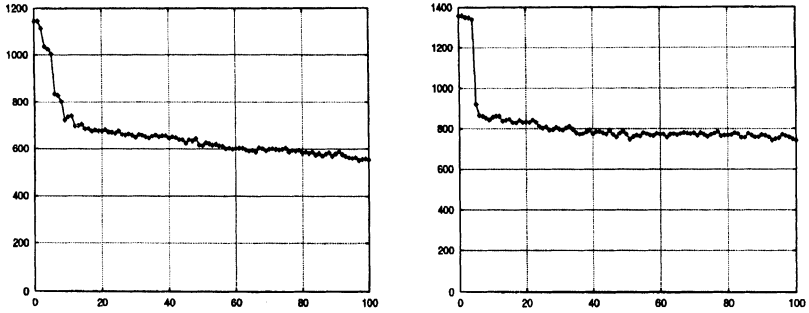

FIGURE 2 A fast beam loss onto the dynamic (left) and physical (right) aperture. The first 100 revolutions are shown.

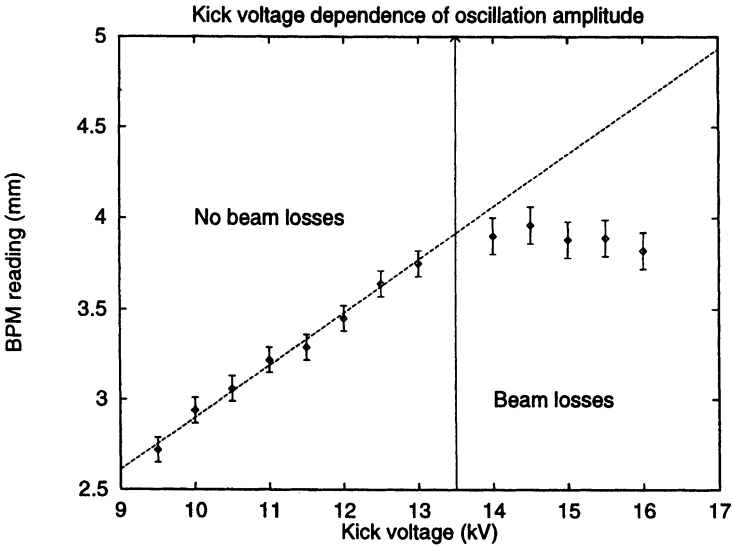

FIGURE 3 BPM coordinate reading as a function of the kick voltage.

after the kick because some beam portion is lost and several dozens revolutions are not enough for the quantum effects to restore the initial beam distribution. This fact should be taken into account when the dynamic aperture is measured by BPM.

To verify our assumption, we consider the beam kicked onto the boundary of the dynamic or physical acceptance $A_x = a_x + X_0$ (see Figure 4). For the Gaussian distribution $\mathcal{P}(x, x')$,⁷ with the rms beam

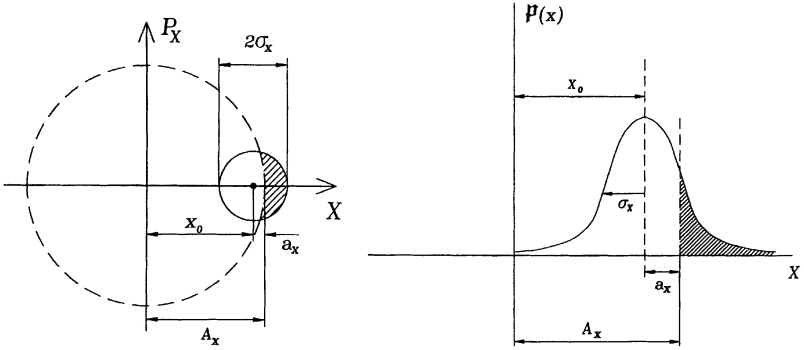

FIGURE 4 Beam is kicked onto the boundary of the dynamic or physical acceptance (left – phase space, right – beam distribution).

size σ_x , the ratio of the beam intensity inside the stable phase area to the initial one $\kappa = I_1/I_0$ is given by the error function⁸

$$\kappa = \frac{1}{2} \pm \Phi(a_x/\sigma_x),$$

$$\Phi(A_x/\sigma_x) = \frac{1}{2} \operatorname{erf}\left(\frac{a_x}{\sqrt{2}\sigma_x}\right),$$

where “+” (“–”) is taken when $\kappa > \frac{1}{2}$ ($\kappa < \frac{1}{2}$). Assuming that $A_x \gg \sigma_x$, we can integrate $\mathcal{P}(x, x')$ over x' from $-\infty$ to $+\infty$. After the beam distribution tail is lost outside the stable acceptance, the BPM coordinate is written as

$$Mx = \frac{\int_{-\infty}^{A_x} x \mathcal{P}(x) dx}{\int_{-\infty}^{A_x} \mathcal{P}(x) dx}.$$

The latter after some manipulations gives

$$X_p = X_0 - \sigma_x \frac{1}{\kappa \sqrt{2\pi}} \exp\left(-\frac{a_x^2}{2\sigma_x^2}\right) = X_0 - \sigma_x F(\kappa),$$

where $X_0 = KU$ is the linear kick amplitude. Knowing the value of κ , one can find $F(\kappa)$. In the reasonable range of $\kappa = 0.2-1$, $F(\kappa)$ can be approximated as

$$F(\kappa) \simeq 1.6(1 - \kappa).$$

FIGURE 5 Measured dependence of $\Delta X(\kappa)$.

Figure 5 shows the measured value of $\Delta X(\kappa) = X_0 - X_p(\kappa) = \sigma_x F(\kappa)$. The horizontal rms beam size extracted from these data $\sigma_x = 0.5 \pm 0.12$ mm corresponds quite well to that obtained by the beam lifetime measurements with a movable scraper ($\sigma_x = 0.55$ mm). The accuracy of the BPM position measurement from kick to kick is determined mostly by the kicker stability and equals 5–7%.

From these measurements we can conclude that the fast beam loss (for 20–50 beam revolutions) actually relates to the aperture limitation, while the long-term beam intensity measurements can include many different effects. For the dynamic aperture measurement we proceed as follows:

1. The coefficient $K = X_p/U$ is found at the low kick amplitude.
2. The kick voltage is increased till the half-beam is lost after the first 20 revolutions, $\kappa = I_{20}/I_0 \simeq 0.5$.
3. The dynamic aperture is defined according to $A_x = KU_{0.5}$.

For a typical VEPP-4M lattice at the injection energy, the measured aperture limitations at the azimuth of BPM station *SRP3* are:

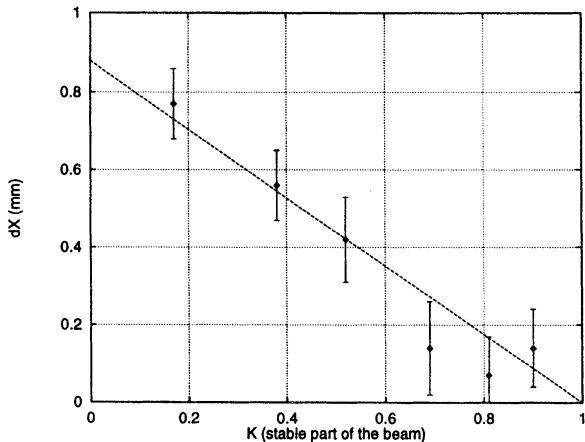
$$\begin{aligned}
 A_x &= 4.5 \text{ mm}, & A_z &= 5.1 \text{ mm}, \\
 \sigma_x &= 0.55 \text{ mm}, & \sigma_z &= 0.42 \text{ mm}, \\
 \beta_x &= 4 \text{ m}, & \beta_z &= 12 \text{ m}.
 \end{aligned}$$

Now the question is how to distinguish which one aperture, dynamic or physical, limits the stable area? To answer this question we have measured the beam loss at the movable scraper. The scraper moves toward the beam orbit with a step as small as 0.1 mm and the fast beam loss is studied. Figure 2 shows the beam loss without scraper and when the latter is inserted into the vacuum chamber. One can see that if the boundary of the motion is determined by the scraper, the beam intensity drops sharply during the first revolution, while for the dynamic aperture limitation several dozens turns are required to get particles out of the stable area.

In case of VEPP-4M, we have the dynamic aperture for the horizontal plane and the physical aperture for the vertical plane.

3 THEORY ANALYSIS

The VEPP-4M model lattice tracking demonstrates the horizontal dynamic aperture twice as large as the measured one.

The sextupole-induced horizontal resonance that is easily reached from the nominal tune $\nu_x = 8.62$ is $3\nu_x = 26$, and the phase space measurement shows typical triangle shape of the phase trajectories.¹ That is why to explain the discrepancy between the tracking and experiment, we consider analytically the horizontal dynamic aperture in the vicinity of the resonance $3\nu = m$. This isolated resonance can be described with the following Hamiltonian:

$$H_r = \delta J_x + \alpha J_x^2 + f J_x^{3/2} \cos 3\phi_x,$$

where J_x and ϕ_x is the action and angle variables, $\delta = \nu_x - m/3$ is the distance from the resonance, α is the nonlinearity, and f is the resonance driving term corresponding to the azimuthal Fourier harmonic of the sextupole perturbation A_3 as

$$f = 2\sqrt{2}A_3 = \frac{1}{12\pi\sqrt{2}} \int_0^{2\pi} \beta_x^{3/2} \frac{B''}{B\rho} \cos[3(\psi_x - \nu_x\theta) + m\theta] d\theta.$$

The action variable relates to the transverse displacement as $x(s) = \sqrt{2\beta_x(s)J_x}$. The contours of constant H_r are shown in Figure 6 in

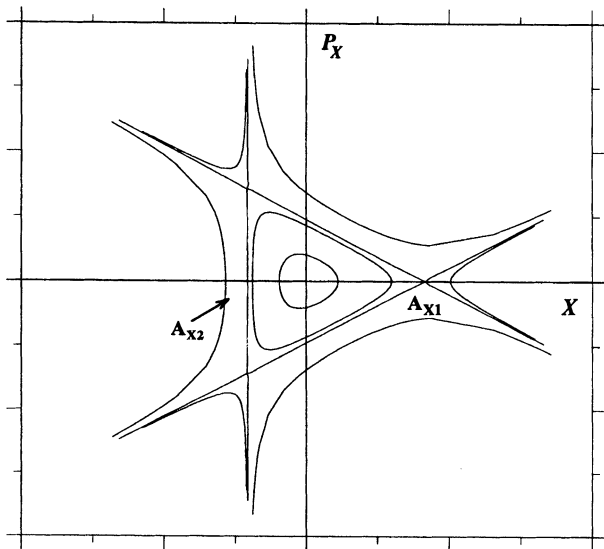
FIGURE 6 Phase space near the resonance $3\nu_x = m$.

the (x, p_x) space. The stable motion is limited by two points which correspond to the action J_{x1} ($\phi_x = 0$) and J_{x2} ($\phi_x = \pi$). The first point is a resonance fixed point and can be found from

$$\frac{\partial H_r}{\partial J_x} = 0, \quad \frac{\partial H_r}{\partial \phi_x} = 0,$$

which yields

$$J_{x1} = \frac{3f}{8\alpha} \left[\left(1 + \frac{32}{9} \frac{\delta\alpha}{f^2} \right)^{1/2} - 1 \right]. \quad (1)$$

The second point J_{x2} is defined by the invariant Hamiltonian $H_r(J_{x1}, 0) = H_r(J_{x2}, \pi)$ that gives a fourth power equation which can be solved numerically.

To calculate the horizontal dynamic aperture from (1) we will use the experimental results presented in Ref. 1:

1. For our tune point $\nu_x = 8.620$ the measured sextupole perturbation harmonic equals $A_3 \simeq -3.1 \text{ m}^{-1/2}$. This value reasonably corresponds to the model one.

2. On the contrary, the measured nonlinearity is much more large than that obtained from the VEPP-4M model lattice. The experimental data show $\Delta\nu_x/a_x^2 = \alpha/\beta_x = 8 \times 10^{-4} \text{ mm}^{-2}$ which corresponds to $\alpha = 3200 \text{ m}^{-1}$ for $\beta_x = 4 \text{ m}$. The study indicates the octupole field errors in the final focus quadrupoles (where the betatron functions reach the value more than 100 m) as a possible source of this nonlinearity.

Substituting these values in (1), we can obtain the following dynamic aperture at the azimuth of BPM *SRP3* ($\beta_x = 4 \text{ m}$):

$$A_x = (+5.1, -3.3). \quad (2)$$

The measured dynamic aperture ($A_x = 4.5 \text{ mm}$) is obtained from the oscillations amplitude averaged over several dozens turns, hence to compare it with the theory result we need to take from (2) the mean

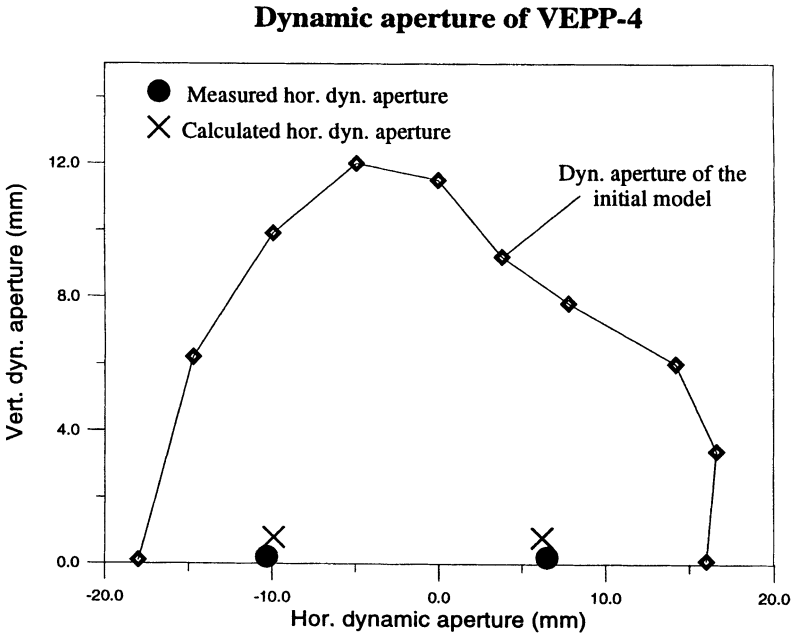

FIGURE 7 Dynamic aperture of the VEPP-4M (ideal lattice, tracking). Measured and estimated (using measured nonlinearity) horizontal dynamic apertures are also shown.

absolute value which equals $A_x = 4.2$ mm. The ideal VEPP-4M lattice gives the aperture of $A_x = (+10, -5)$ that is significantly larger than the measured one.

Apart from the analytic estimation, computer tracking of the realistic lattice has been performed with the octupole field incorporated into the final focus quadrupoles to provide the measured detuning effect. The tracking results agree with the theoretical results.

In Figure 7 the ideal dynamic aperture is shown together with the measured and calculated values of the horizontal aperture. All data are presented for the centre of the straight section where $\beta_x = 14$ m and $\beta_z = 3$ m.

4 DYNAMIC APERTURE INCREASE

According to (1), we need to reduce either the resonance driving term $f = 2\sqrt{2}A_3$ or nonlinearity α to open the dynamic aperture. We have verified each of these ways as well as combined both of them.

As the strong final focus sextupoles *SES2* and *NES2* strongly contribute to the harmonic A_3 , we have decreased their excitation current from 8.4 to 4.3 A. The residual chromaticity was compensated by the distributed sextupole correctors in the arcs.

As was shown in Ref. 1, in our case the horizontal nonlinearity is defined by the octupole perturbation. So, we have used the octupole coils in the arcs (which are not energised in the routine operation mode) to decrease the nonlinearity by a factor of 1.7.

The first way (sextupole harmonic reduction) results in the horizontal aperture enhancing up to 7 mm, which is more than 1.5 times larger than the initial one. On the contrary, the octupole corrections do not provide significant aperture increase (5.4 mm). Measurements done after combining the two approaches indicate that the aperture increased up to 5.9 mm which is less than that obtained with the sextupole correction only.

The latter seems to be rather strange because the tracking for all three cases shows that the best result (up to 10 mm) is obtained in case when two kinds of corrections are used simultaneously. A possible explanation is that the octupole perturbation excites additional high-order resonances which create obstacles to the aperture

increasing. This discrepancy is the topic of the continuing investigation. The simulation of the sextupole harmonic reduction corresponds quite well to the measurement results.

5 CONCLUSION

In conclusion, we have experimentally measured the dynamic aperture of the VEPP-4M storage ring. The measurements have been made by the turn-by-turn particle tracking system. As it was found for VEPP-4M, the horizontal aperture is limited by the nonlinear fields, while the vertical one is defined by the physical limitation.

The Hamiltonian for the particle motion was derived using the experimental data. The stable motion boundary, obtained with the single resonance approximation, shows good agreement with the measurement results.

We have increased the horizontal aperture by the sextupole resonance driving term reduction. But we failed to do the same by the detuning compensation with the octupole field corrections. We suspect that this might be due to the additional higher-order resonances excited by the octupole corrector.

Acknowledgement

We wish to thank I.Ya. Protopopov, the head of VEPP-4M, for providing us with the opportunity to perform the nonlinear experiments, G. Kulipanov and V. Korchuganov for their valuable discussions, A. Kalinin for the turn-by-turn measurement assistance.

References

- [1] V. Kiselev, E. Levichev, V. Sajaev and V. Smaluk. Nonlinear beam dynamics study at VEPP-4M. *The Proc. of the EPAC'96*, Vol. 2, pp. 896–898, 1996.
- [2] V. Anashin *et al.* Status of the VEPP-4M storage ring. *The Proc. of the XII Russian Part. Acc. Conf.*, Dubna, Vol. 1, p. 369, 1993 (in Russian).
- [3] P.L. Morton *et al.* A diagnostic for dynamic aperture. SLAC-PUB-3627, 1985.
- [4] J. Bridges *et al.* Dynamic aperture measurement on Aladdin. *Particle Accelerators*, **28**, 1–9, 1990.
- [5] S.Y. Lee *et al.* Experimental determination of a nonlinear Hamiltonian in a synchrotron. *Phys. Rev. Lett.* **67**(27), 3768–3771, 1991.

- [6] A. Dubrovin *et al.* Applications of beam diagnostic system at the VEPP-4 complex. *The Proceedings of the EPAC'96*, Vol. 2, pp. 1585–1587, 1996.
- [7] M. Sands. The physics of electron storage rings (An Introduction). SLAC Report No. 121, 1970.
- [8] G.A. Korn. *Mathematical Handbook for Scientists and Engineers*. McGraw-Hill Book Co., New York, 1961.