

THE USE OF MULTIWIRE PROPORTIONAL COUNTERS
TO SELECT AND LOCALIZE CHARGED PARTICLES

G. Charpak, R. Bouclier, T. Bressani, J. Favier
and Č. Zupančič

CERN, Geneva, Switzerland.

ABSTRACT

Properties of chambers made of planes of independent wires placed between two plane electrodes have been investigated. A direct voltage is applied to the wires. It has been checked that each wire works as an independent proportional counter down to separation of 0.1 cm between wires.

- Counting rates of 10^5 /wire are easily reached.
- Time resolutions of the order of 100 nsec have been obtained in some gases.
- It is possible to measure the position of the tracks between the wires using the time delay of the pulses.
- Energy resolution comparable to the one obtained with the best cylindrical chambers is observed.
- The chambers can be operated in strong magnetic fields.

Geneva - 23 February, 1968

(Submitted to Nucl. Instrum. and Methods)



THE USE OF MULTIWIRE PROPORTIONAL COUNTERS
TO SELECT AND LOCALIZE CHARGED PARTICLES

G. Charpak, R. Bouclier, T. Bressani, J. Favier
and Č. Zupančič

CERN, Geneva, Switzerland.

Proportional counters with electrodes consisting of many parallel wires connected in parallel have been used for some years, for special applications. We have investigated the properties of chambers made up of a plane of independent wires placed between two plane electrodes. Our observations show that such chambers offer properties that can make them more advantageous than wire chambers or scintillation hodoscopes for many applications.

1. CONSTRUCTION

Wires of stainless steel, 4×10^{-3} cm in diameter, are stretched between two planes of stainless-steel mesh, made from wires of 5×10^{-3} cm diameter, 5×10^{-2} cm apart. The distance between the mesh and the wires is 0.75 cm. We studied the properties of chambers with wire separation $a = 0.1, 0.2, 0.3,$ and 1.0 cm. A strip of metal placed at 0.1 cm from the wires, at the same potential (Fig. 1), plays the same role as the guard rings in cylindrical proportional chambers. It protects the wires against breakdown along the dielectrics. It is important to have the last wire on each side much thicker than the other ones in order to avoid a too high gradient on these wires. Each wire is connected to an amplifier with an input impedance of about 10 k Ω .

The chamber is flushed at atmospheric pressure by a flow of ordinary argon bubbling through an organic liquid at 0°C: ethyl alcohol, or n-pentane or heptane. A negative constant voltage is applied to the external electrodes.

2. PROPERTIES OF THE CHAMBER

2.1 Amplification

At the distances from the wires at which amplification occurs, the equipotentials are concentric to the wires. We thus expect the amplification to behave exactly as in a cylindrical proportional counter. Figure 2 shows the distribution of these equipotentials for a chamber with a separation $a = 0.3$ cm between the wires. We have studied the amplification factor of such a chamber as a function of applied voltage. The pulses from the wires are amplified by a factor of 200 by a simple three-transistor amplifier of 10 k Ω input impedance. In cylindrical chambers the amplification factor A is given by a formula obtained under simple assumptions¹⁾, which shows that $\log A$ is proportional to

$$f = V^{1/2} \left[\frac{V^{1/2}}{V_S^{1/2}} - 1 \right]$$

where V is the voltage applied between the wires and the external electrode, and V_S is the threshold at which amplification begins. We used as calibration source ^{55}Fe , which emits a 5.9 keV X-ray line. The variation of pulse height in argon-alcohol over a large range of voltages (Fig. 3) shows that the behaviour of the wire is, indeed, that expected for a cylindrical counter. The threshold for proportional amplification is at $V_S = 1100$ volts. At 1700 V the counter may enter into the semi proportional region, but as long as we are interested in counting, rather than in linearity, this is still acceptable. At 1800 V we obtain a 5.5 mV pulse directly from the wire, on a 30 pF load. This corresponds to an amplification factor of about 5000. At 1800 V the critical radius at which the amplification starts is, to a very good approximation¹⁾:

$$r_0 = \rho \frac{V}{V_S} = 3.3 \times 10^{-3} \text{ cm} .$$

ρ being the wire radius. We thus see that it is a region where the equipotentials are exactly concentric to the wire.

1) S.C. Curran and J.D. Craggs, Counting Tubes (Butterworths Scientific Publications, London, 1949), p. 32.

2.2 Energy resolution and efficiency for detecting charged particles

Many data have been accumulated about the properties of the different gases suitable for proportional counters. We have concentrated our efforts on selecting a gas giving the maximum amplification, so that the minimum gain is required from the amplifiers. We found that ordinary argon, bubbling through n-pentane or heptane cooled at 0°C, gave very satisfactory results. With n-pentane we could reach pulses of 100 mV directly on the wire without entering into the Geiger region. Figure 4 shows the energy distribution obtained from 5.9 keV X-rays, with a simple three-transistor amplifier. With a refined amplifier the resolution is 15%.

Figure 5 shows the energy loss distribution from β rays traversing the counter. We see that the threshold of detection is well below the minimum energy loss. Energy resolution is important in that respect, because a poor energy resolution gives rise to an increase of low-energy pulses.

We have studied the energy lost in the counter by pions and protons of 370 MeV/c from the CERN Synchro-cyclotron, in argon-alcohol mixtures, where the energy resolution was poorer (25 to 30% at 6 keV). Figure 6 shows the observed spectrum, together with the theoretical energy loss distribution, corrected for the finite resolution. We see how essential it is to have a threshold of detection in the region of 100 eV if one wishes to be close to 100% efficiency for minimum ionizing particles.

Figure 7 shows the separation of the energy loss distributions for the pions and protons of 370 MeV/c at two different voltages.

2.3 Localization

If we work in the region of proportional amplification, where the propagation of the discharge by photons plays no role, we should expect each wire to be independent of the others. We have verified this property with a beam of particles, pions and protons of 370 MeV/c, collimated to 0.06 cm (FWHM) by means of small counters in coincidence. Figure 8 shows the spectrum obtained from such a beam of protons passing in the chamber near a wire, and the variation of the spectrum as we vary the distance from the wire. Figure 9 shows the variation of the efficiency as a function of the distance from the wire, for wire separation of 0.3 cm and

0.2 cm. We see that the sharpness in the variation of the efficiency is exactly equal to the definition of the beam width: 0.06 cm. The counting rate at large distances from the wire is due to accidental coincidences between the beam telescope and the chamber (gate width 5 μ sec). We may then conclude that the accuracy of localization can be brought down, at least to this limit. We have repeated these measurements with a wire separation of 0.1 cm. An efficiency of only 95% was reached at the position of the wire with the same fall-off sharpness and the 5% loss is probably due to the imperfect collimation of the beam. Similar results were obtained with pions.

2.4 Counting rate and time resolution

We have counted up to 250,000 particles per second on a wire, the limit being set by our amplifiers. More than 10^7 β rays were traversing the chamber, 20 x 5 cm, with no visible interference between the wires. The resolution time of the chamber is in principle determined by the jitter in the arrival time at the wire of electrons liberated in the gas. We may expect this time to vary as a function of the chamber geometry, of the electronics, of the gas mixture, and of the voltage. Our preliminary investigations show that with no precaution one obtains about 0.5 μ sec, as in spark chambers. Using a source of β rays collimated down to 0.1 cm width, we observe a very interesting property. We measure the time interval between the traversal of the chamber by the electron and the detection on the wire.

We see that at the wire the width (FWHM) of the time distribution can reach 40 nsec (Fig. 10). But, as expected, this delay is shifted as we go away from the wire, since the distance to the wire is increased and since the gradients decrease further away from the wire. In the worst case of the argon-alcohol mixture (Fig. 11), the maximum time delay is of the order of 0.4 μ sec. Some additional jitter is introduced there by the fact that the pulses are smaller than with n-pentane, and the time response of our electronics is not independent from the pulse height.

The variation in the delay with the distance from the wire may be exploited to give the position of the particles between the two wires. It seems to us that this may lead to spatial resolutions much better than any reached so far, and which may be of great interest when very high

energy particles have to be localized. It is likely that a time resolution much smaller than the one for spark chambers will be attained after appropriate research on the gas mixtures and on the detecting electronics.

2.5 Operation in a magnetic field

We have tested the chambers in a magnetic field at 7500 gauss, parallel and orthogonal to the wires, with a beam of collimated 5.9 keV X-rays. The displacement of the spatial distribution was found to be inferior to 0.2 mm. The energy resolution was not altered.

3. CONCLUSION

The properties of the multiwire proportional chambers can be summarized as follows:

- Each wire can amplify the initial energy loss of a particle in a thin layer of gas, of the order of 1 cm, to such an extent that minimum ionizing particles are detected with an efficiency close to 100%.
- With argon-n-pentane and argon-heptane mixtures, high amplification is possible, making easy the amplification by rudimentary solid-state amplifiers.
- With wires that are 0.1, 0.2, 0.3, and 1.0 cm apart, we have observed a good localization of the detection on each single wire.
- Any number of simultaneous particles can be detected.
- Resolution times below 0.4 μ sec are readily obtained.
- Localization of the position between the wires is possible, making use of the arrival time of the pulse.
- Counting rates of the order of 2.5×10^5 /sec per wire have been observed.
- Selection between particles with different ionization powers is possible.
- The chambers can be operated in strong magnetic fields.

These observations give us confidence that this type of instrument deserves a very detailed study since it can in some respects replace classical wire chambers or hodoscopes, or be a useful complementary tool, for

instance as a fast decision-making chamber to trigger spark chambers. It is an ideal anticoincidence counter in front of gamma or neutron detectors, because of its very low efficiency. Since it does not require a trigger from a scintillation counter it has considerable advantages in the measurement of the spatial distribution of X-rays, γ rays, or neutrons with the eventual association of proper radiation converters.

* * *

We wish to thank Messrs. G. Million and J.M. Fillot for their technical help. We benefitted greatly from the support given to us by Mr. G. Muratori and his group, who demonstrated that the large-scale production of this type of chamber is possible.

Messrs. G. Amato and J.P. Papis were of great help in the research into very low-cost amplifiers and were successful in this respect. They showed that less than two dollars of equipment per wire was sufficient to bring the pulses to a level close to 1 volt, where their utilization by logic circuits is easy.

We are pleased to thank Prof. P. Preiswerk for his encouragement.

Figure captions

- Fig. 1 : Some details of the construction of the multiwire chambers.
A copper shield protects the wires at their output from the chamber, and contains the solid-state amplifiers.
- Fig. 2 : Equipotentials in a chamber. Wires of 4×10^{-3} cm diameter, 0.3 cm separation, and 1.5 cm total thickness. 20 volts applied between the wires and the external mesh. Results from an analogic method.
- Fig. 3 : Relation between the amplification factor A in the gas and the applied voltage V. In cylindrical chambers log A is proportional to $f = V^{1/2}[(V^{1/2}/V_S^{1/2}) - 1]$, where V_S is the threshold. Argon-alcohol filling, wire diameter 4×10^{-3} cm, wire spacing 0.3 cm. $A \sim 50$ at 1400 V, $A \sim 5000$ at 1800 V.
- Fig. 4 : Pulse-height spectrum from one wire. 5.9 keV line from ^{55}Fe and escape line of 3 keV. Argon-pentane filling, wire diameter 5×10^{-3} cm, wire spacing 0.3 cm, 3750 volts. Pulse-height on the wire: 5 mV at 6 keV, on a 10 pF capacitance.
- Fig. 5 : Pulse-height spectrum from one wire. β rays from ^{90}Sr collimated on the wire. Argon-pentane filling, wire diameter 4×10^{-3} cm, wire spacing 0.3 cm, HV = 3000 V, peak at about 2 keV energy loss. Only the lowest energy part is displayed.
- Fig. 6 : Energy loss distributions by pions and protons of 370 MeV/c. 2.4×10^{-3} g cm^{-2} of argon-alcohol. Experimental points and theoretical curve corrected for finite resolution: 30% at 6 keV varying as $E^{-1/2}$.
a) Pions : Mean energy loss 3.6 keV.
b) Protons: Mean energy loss 15.3 keV.
- Fig. 7 : Energy loss distributions by pions and protons of 370 MeV/c. Argon-alcohol filling.
a) HV = 1509 volts.
b) HV = 1629 volts.

- Fig. 8 : Pulse height as a function of distance from the wire. Beam of protons of 370 MeV/c, 0.06 cm wide (FWHM). Argon-alcohol filling, HV = 1509 volts, wire diameter 4×10^{-3} , wire spacing 0.2 cm.
- a) Beam on the wire.
 - b) Beam 0.05 cm from the wire.
 - c) Beam 0.075 cm from the wire.
 - d) Beam 0.1 cm from the wire.
 - e) Beam 0.15 cm from the wire.
- Fig. 9 : Efficiency of detection as a function of position. Beam of protons of 370 MeV/c. Argon-alcohol filling, HV = 1509 volts, wire diameter 4×10^{-3} cm.
- a) Wire spacing 0.3 cm.
 - b) Wire spacing 0.2 cm.
- Fig. 10 : Delay in the pulse as a function of the distance wire-particle.
- Argon-n-pentane filling.
 - Wire of 0.004 cm.
 - Distance between wires: 0.3 cm.
 - High voltage 2240 volts.
 - a) Collimated beam of β rays (~ 1 mm width) centred on the wire. FWHM = 40 nsec.
 - b) Effect of a displacement by 0.1 cm from the wire.
- Fig. 11 : Delay in the pulse as a function of the distance wire-particle.
- Argon-alcohol filling.
 - Wires of 0.004 cm.
 - Distance between wires: 0.3 cm.
 - High voltage 1600 volts.
 - a) Collimated beam of β rays.
 - b) Uncollimated beam.
 - c) Effect of displacement by 0.1 cm from the wire of the collimated beam.

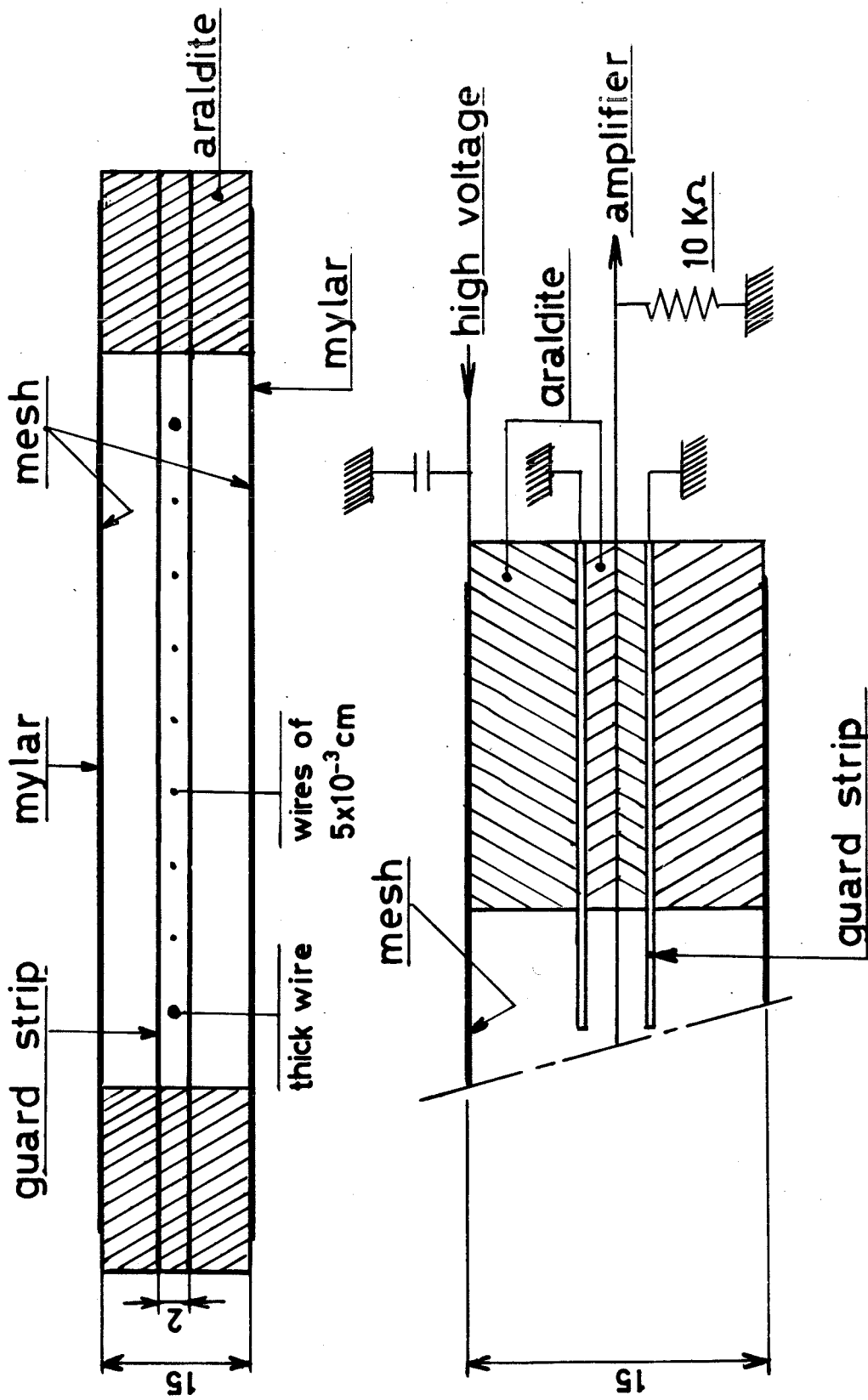
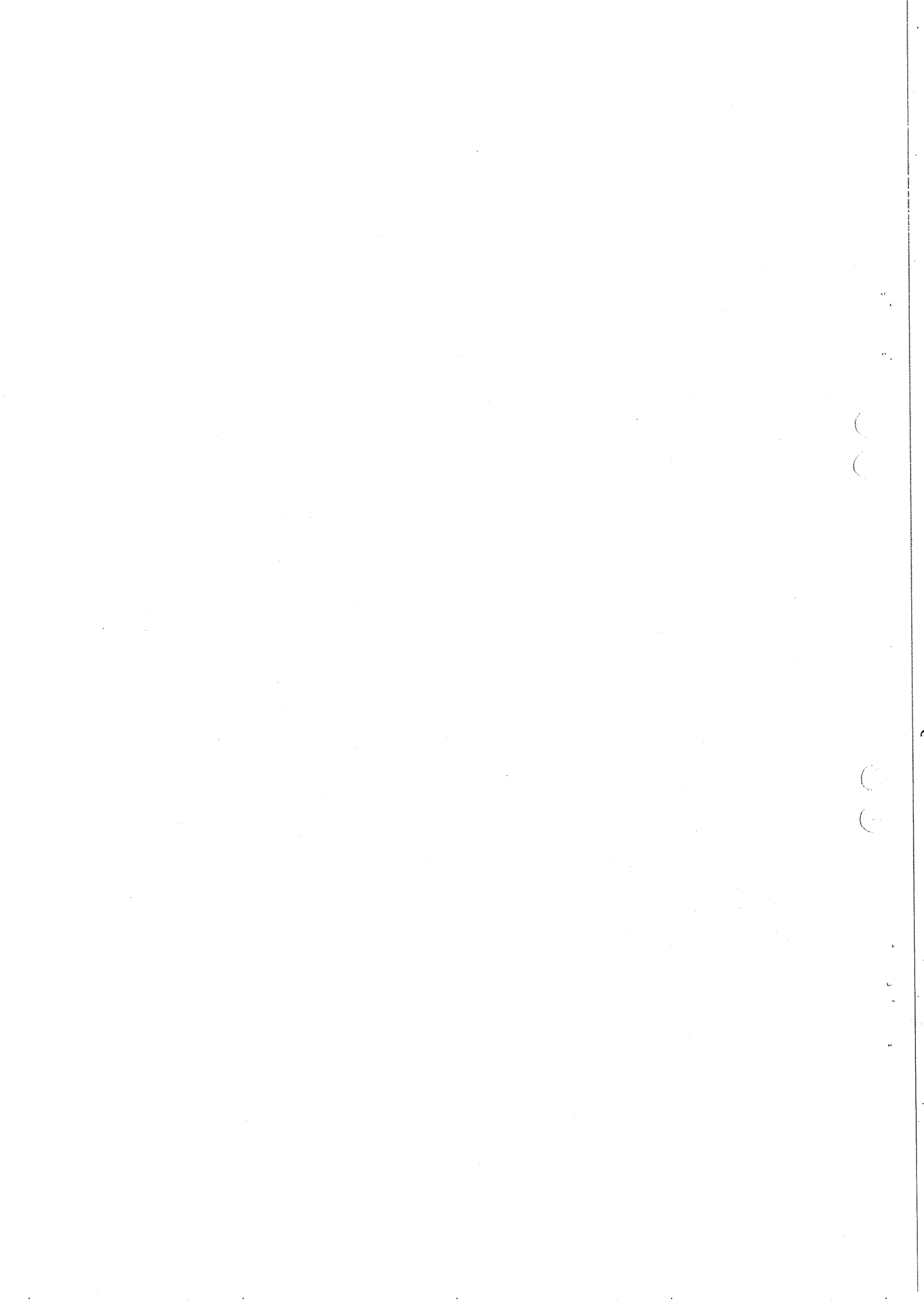

Fig.1



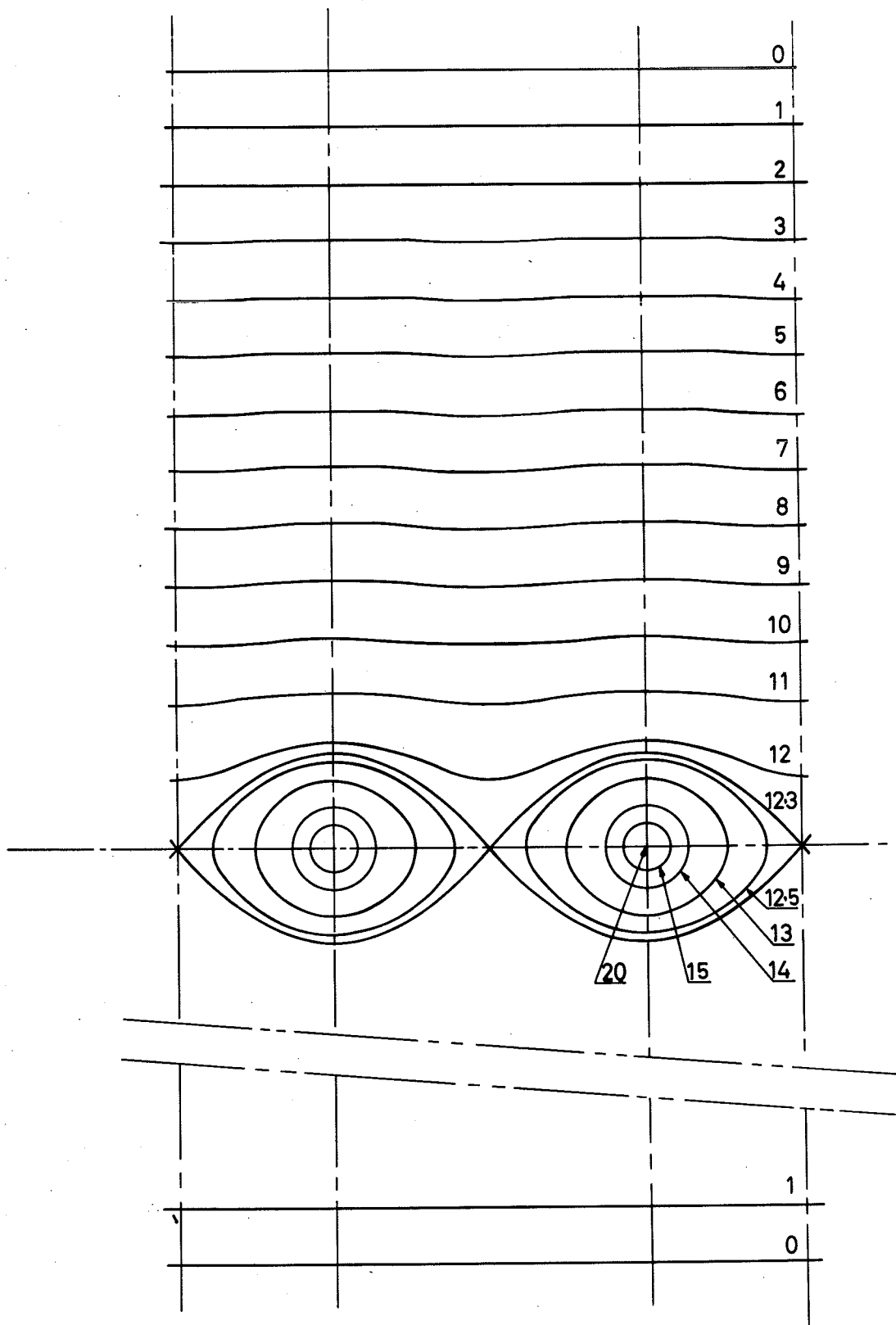
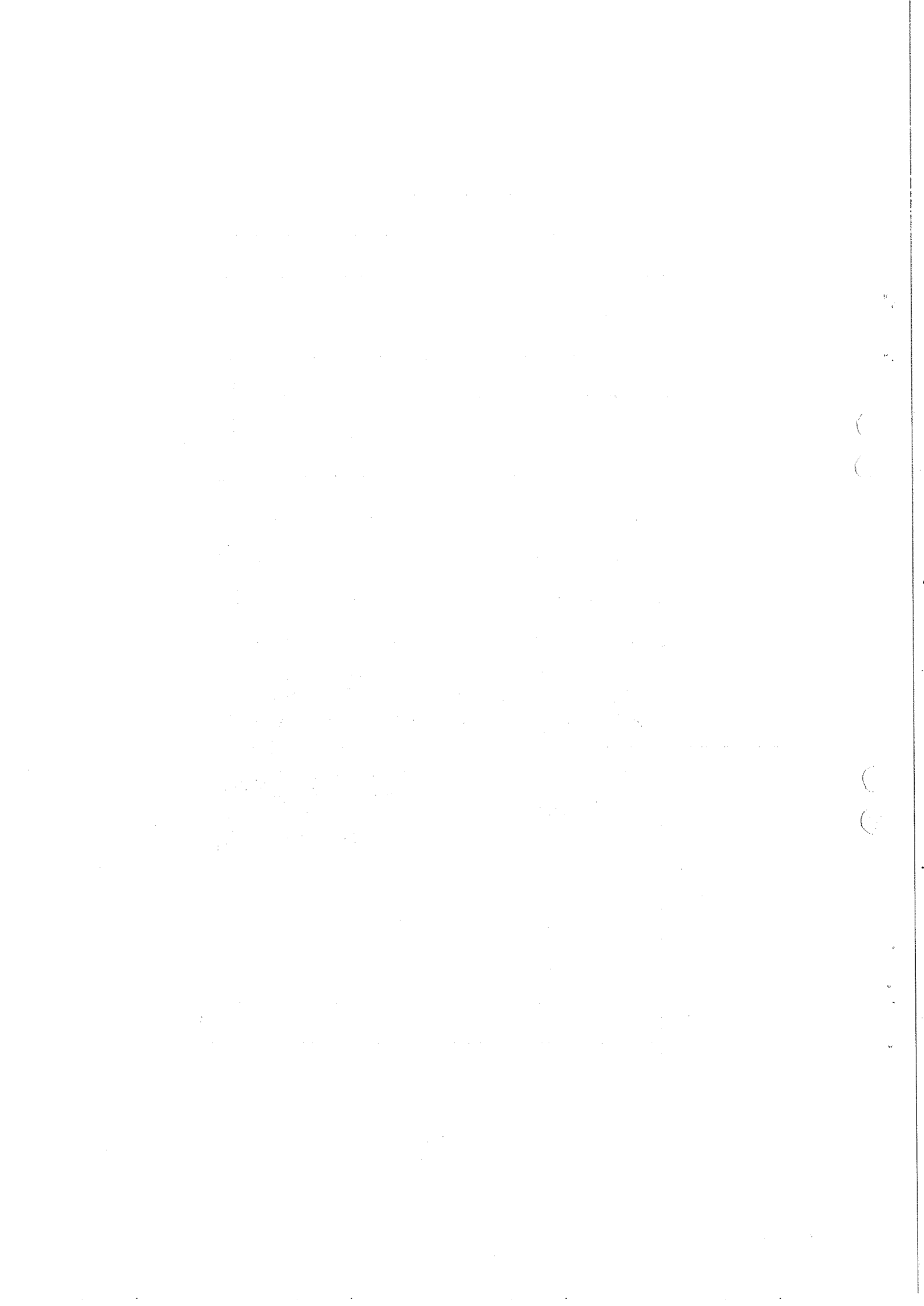

FIG. 2



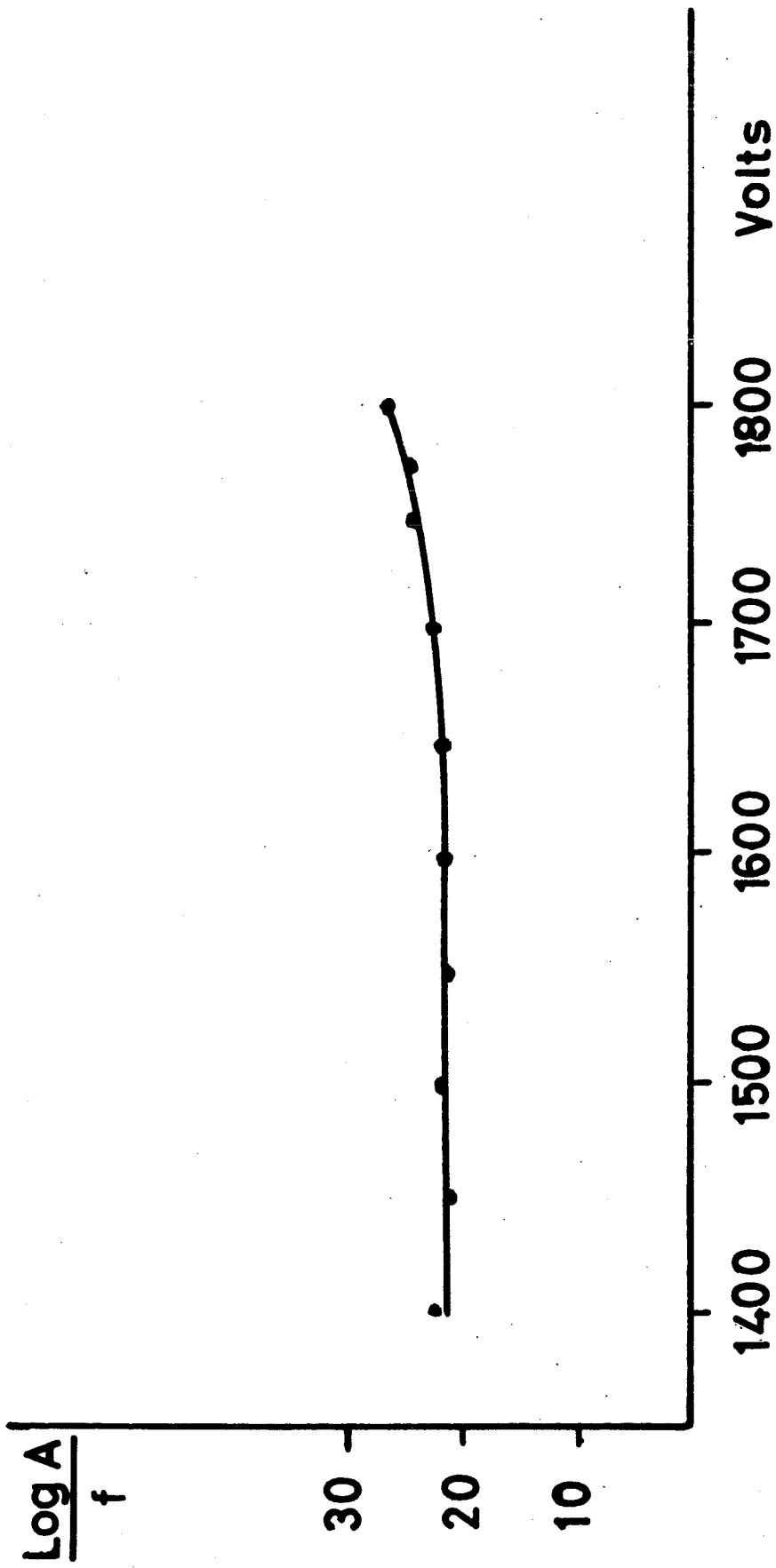

Fig.3

1000

1000

1000

1000

1000

1000

1000

1000

1000

1000

(

(

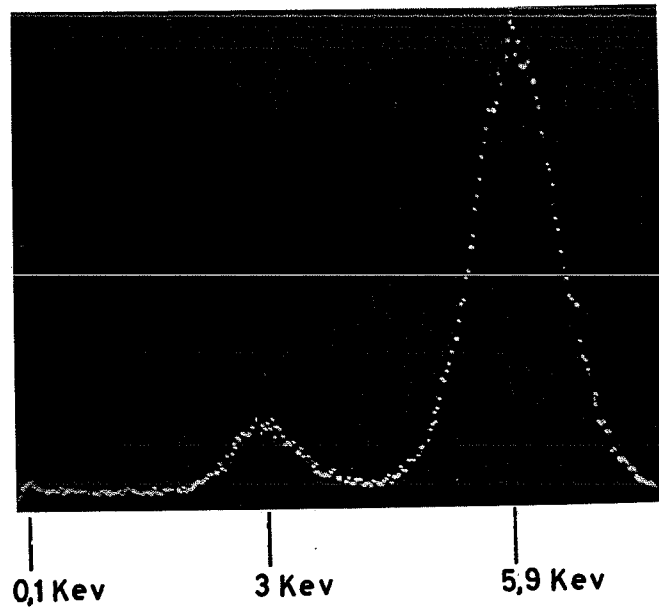

Fig.4

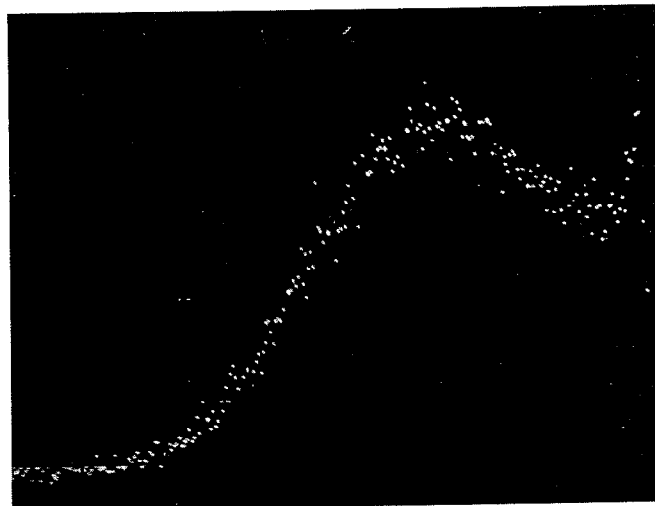

Fig.5

1. The first part of the document discusses the importance of maintaining accurate records of all transactions. It emphasizes that this is crucial for ensuring the integrity of the financial statements and for providing a clear audit trail. The text also mentions that proper record-keeping is essential for identifying and correcting errors in a timely manner.

2. The second part of the document focuses on the role of internal controls in preventing fraud and misstatements. It highlights that a strong internal control system is necessary to ensure that all transactions are properly authorized, recorded, and reviewed. The text also notes that internal controls should be designed to be effective and efficient, and should be regularly evaluated and updated as needed.

(
(

(
(

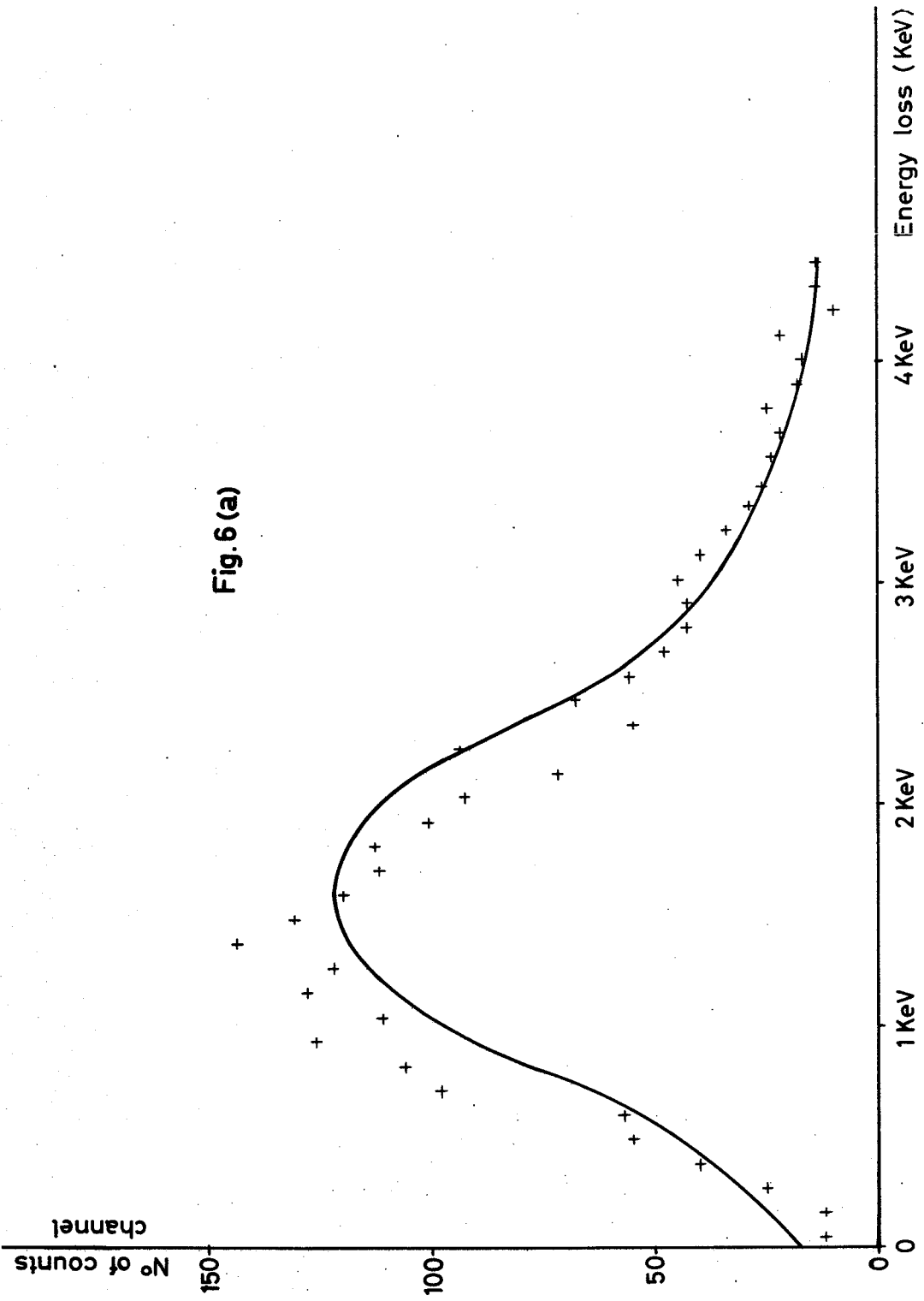

1000
900
800
700
600
500
400
300
200
100
0

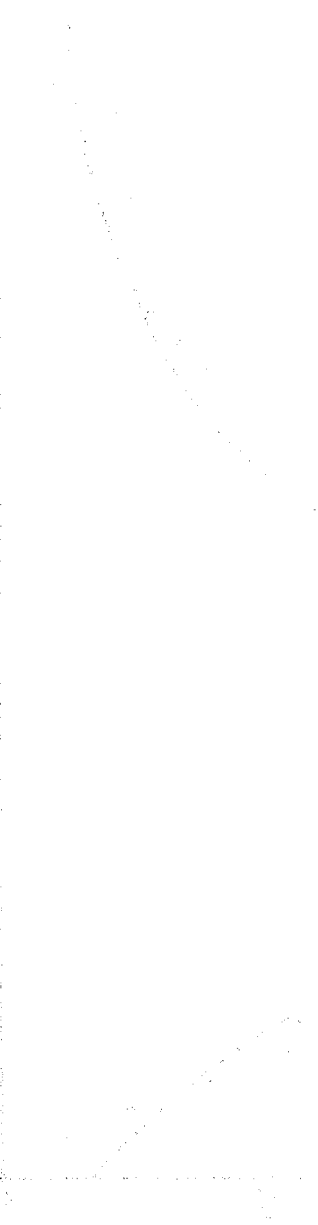

1000

1000
900
800
700
600
500
400
300
200
100
0

1000

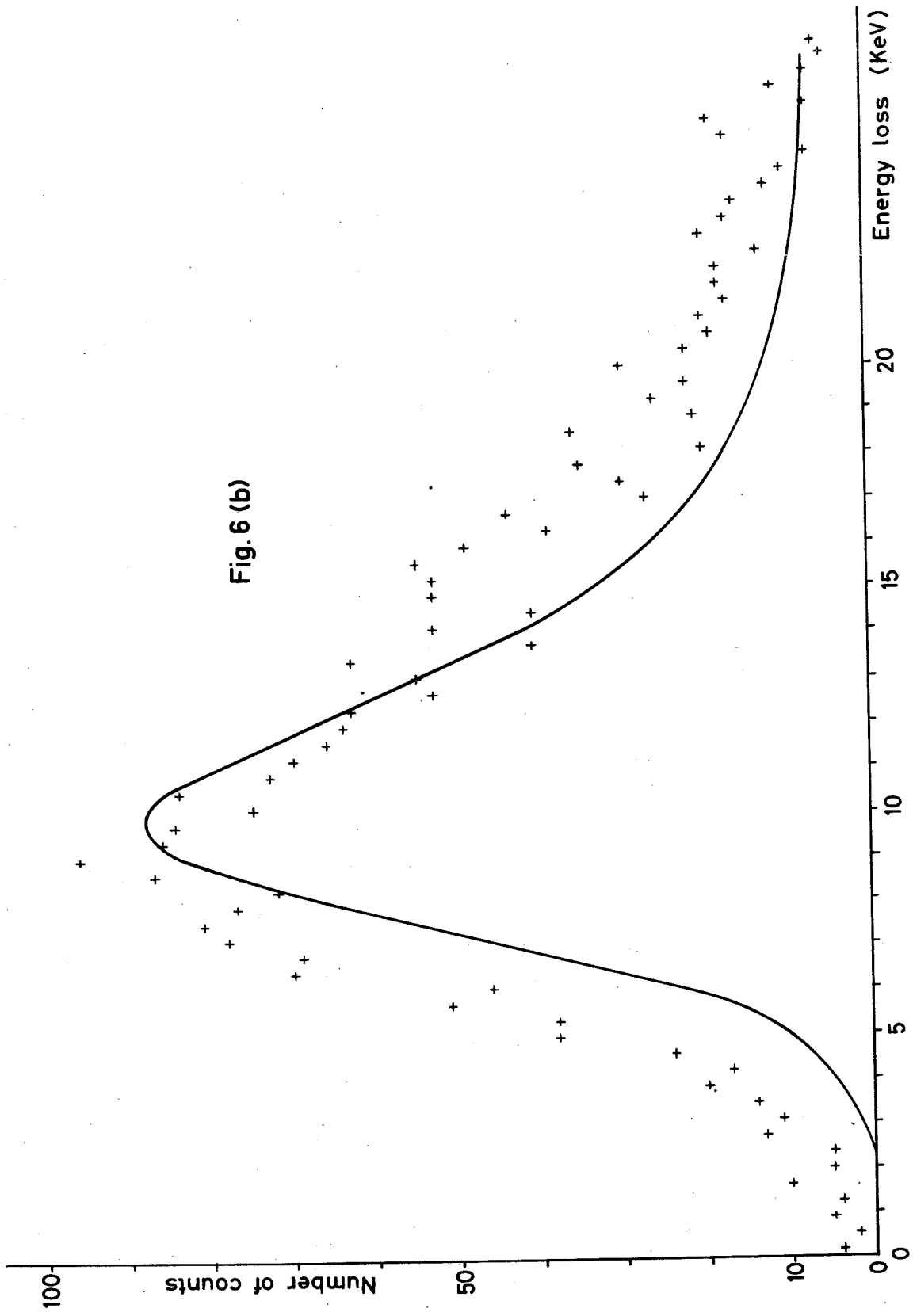

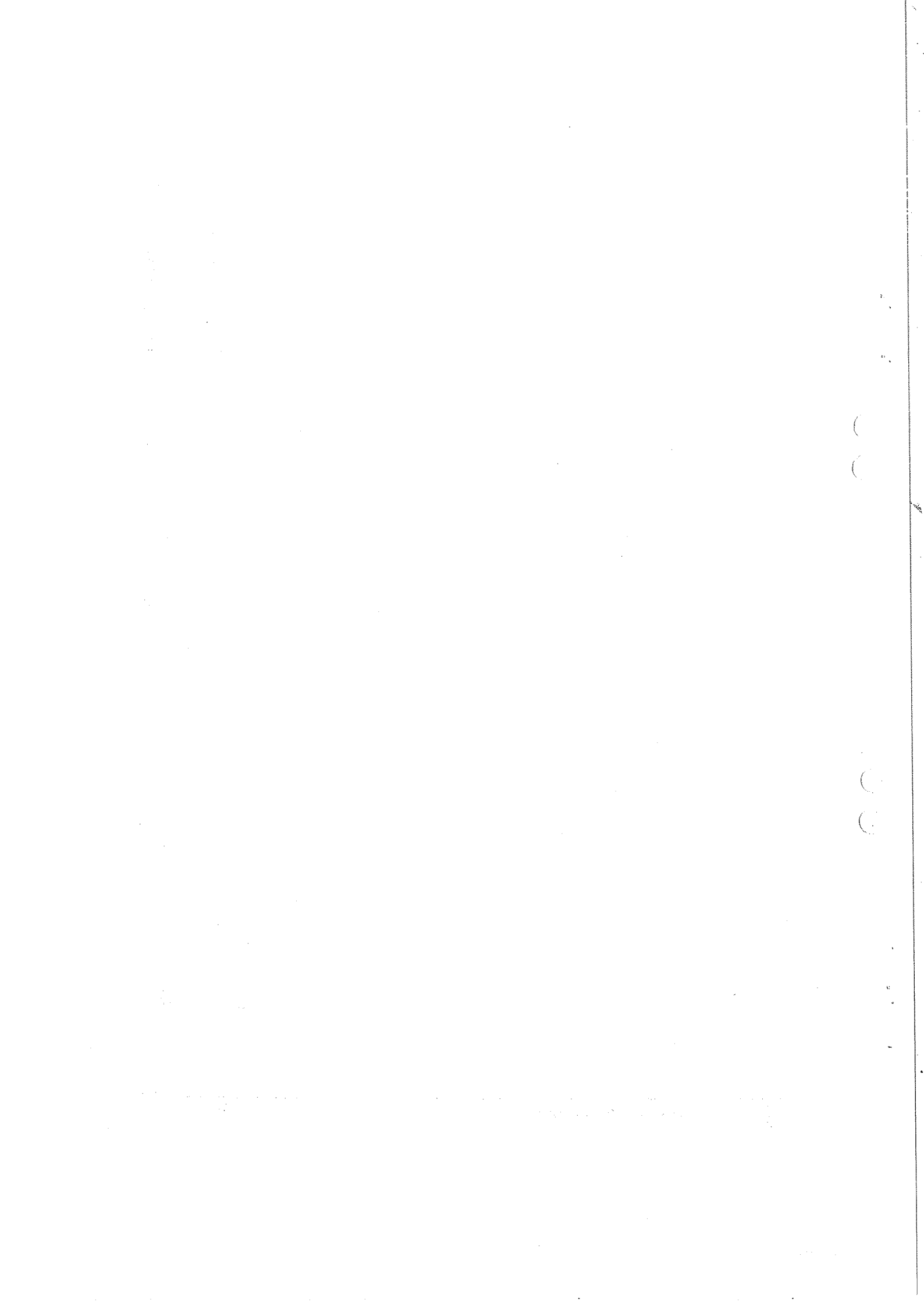

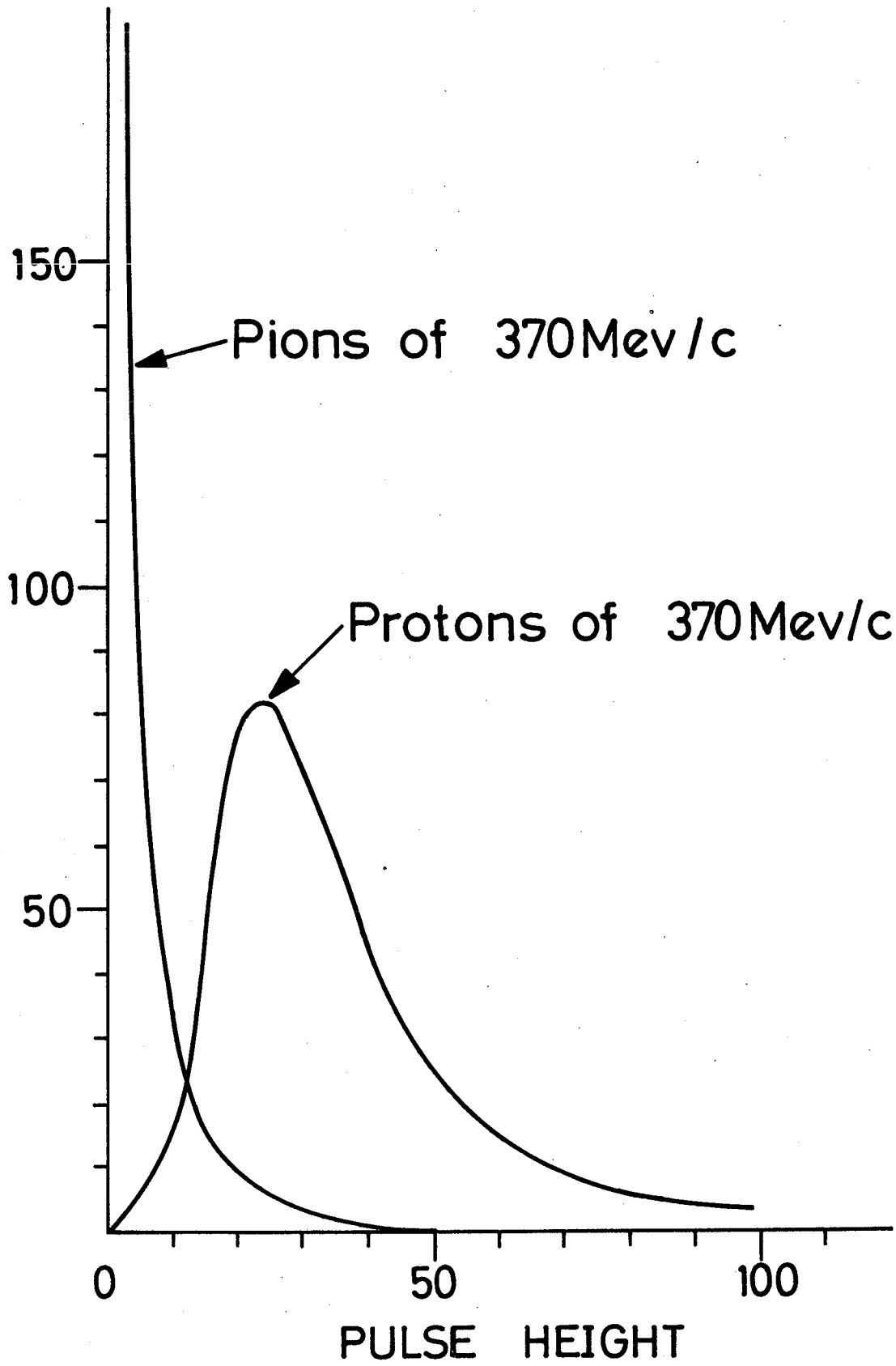

FIG. 7a

1940

1941

(

(

(

(

1942

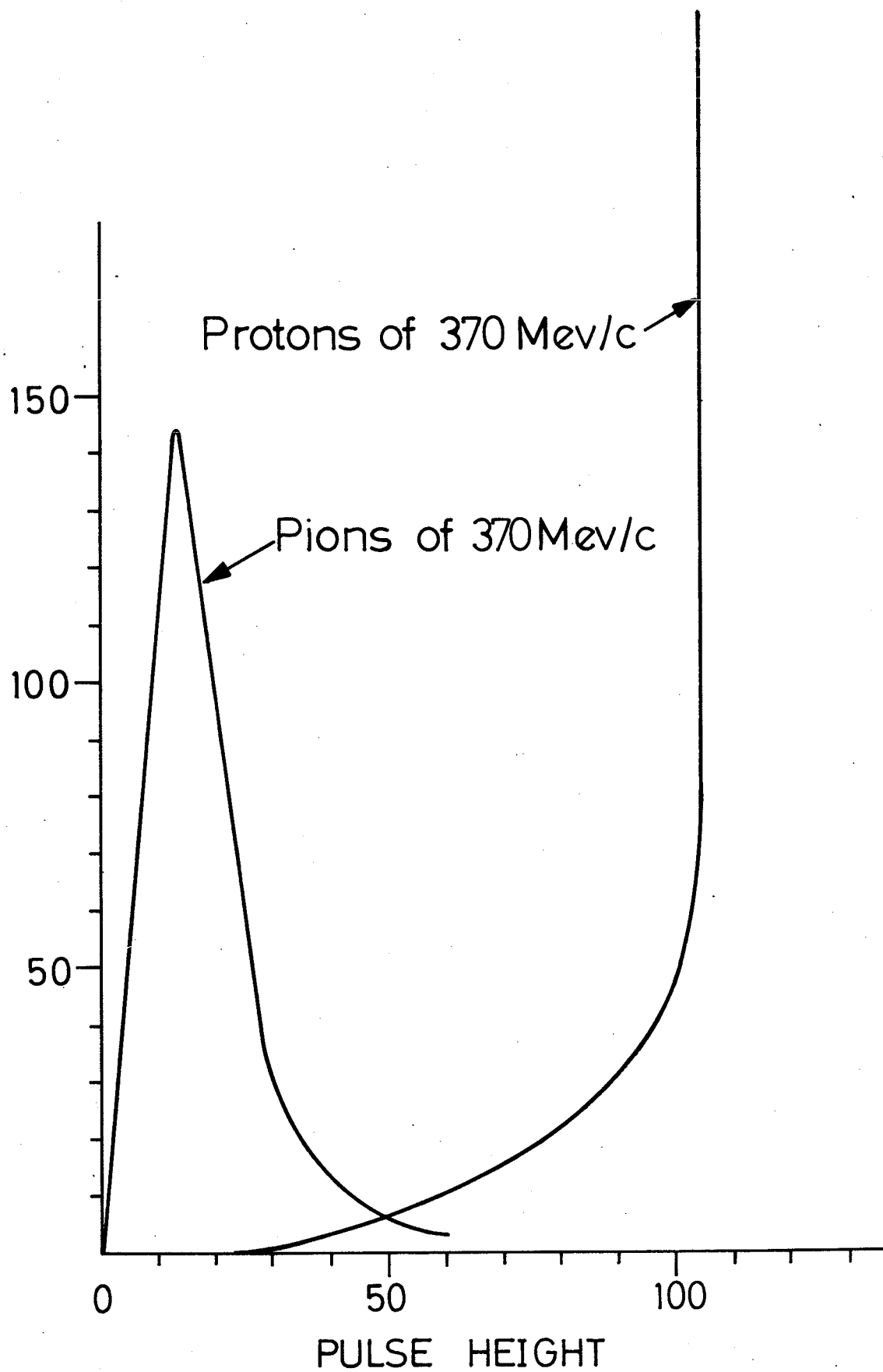
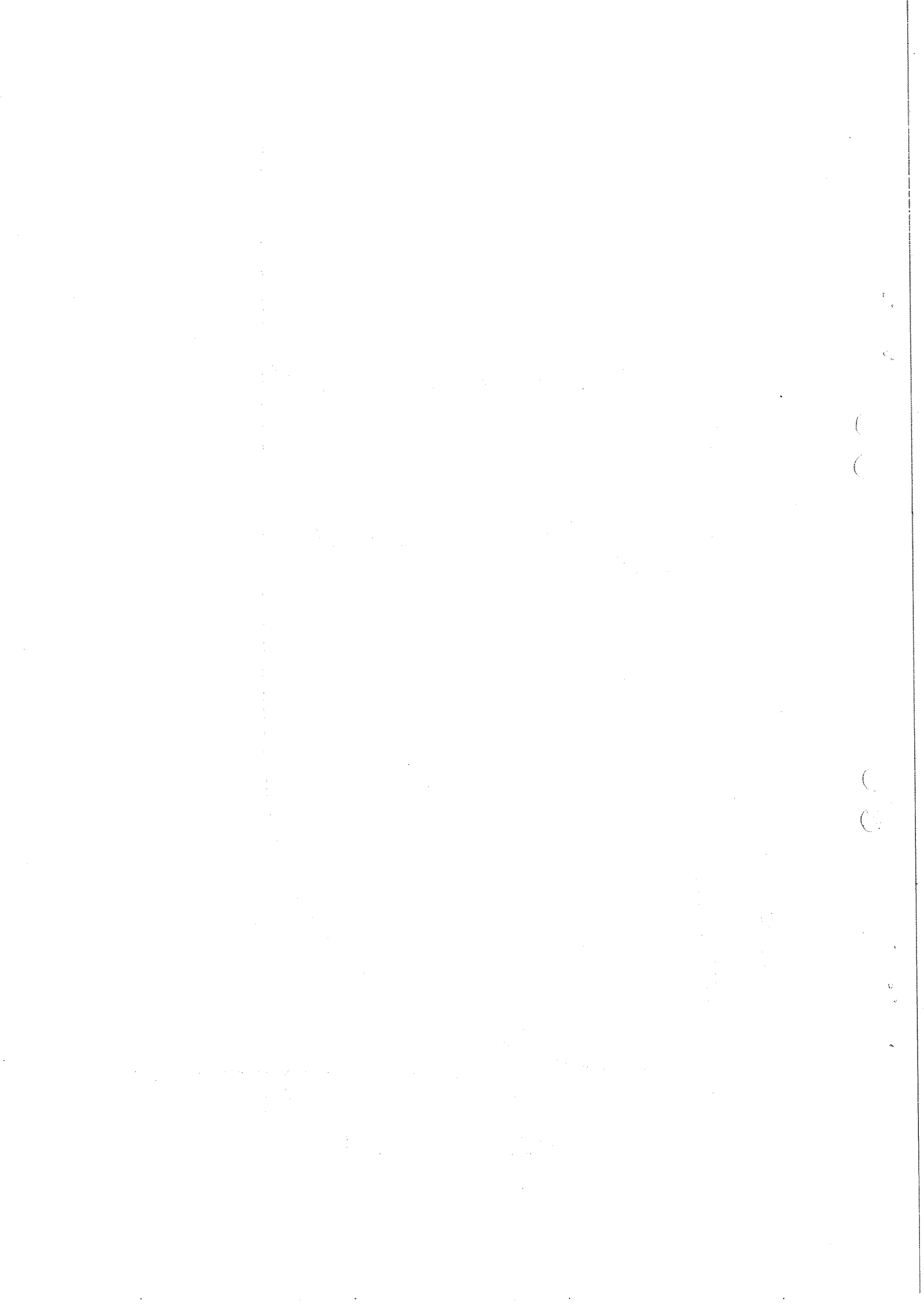
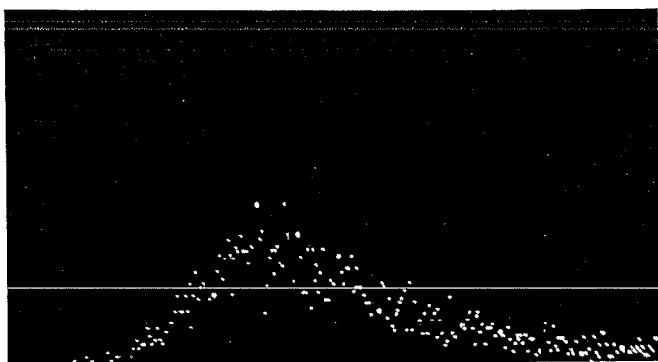
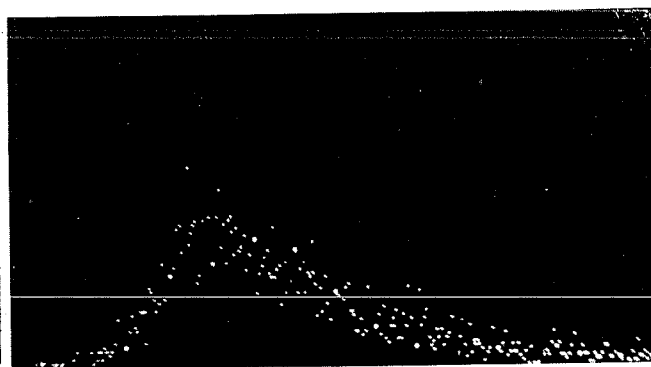

FIG. 7 b





a



b



c

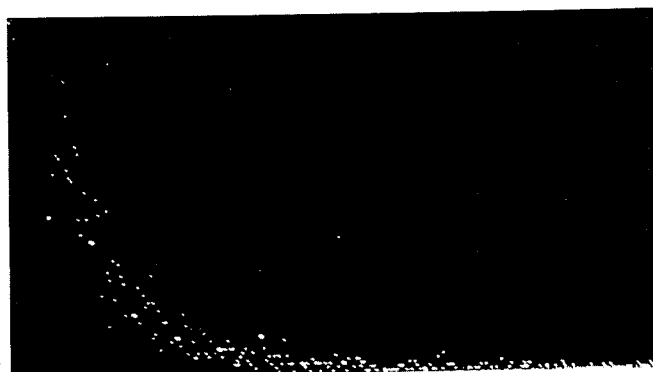

d

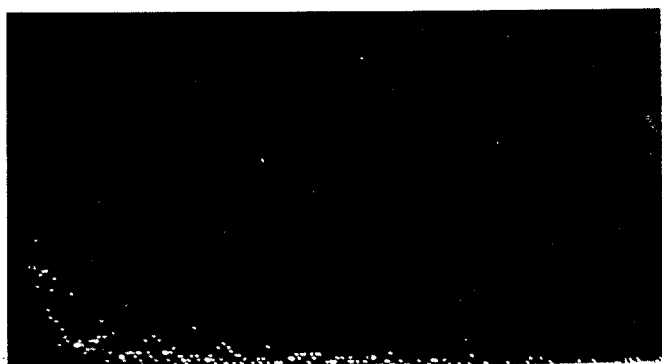

e

Fig. 8

[Faint, illegible text block]

[Faint, illegible text block]

[Faint, illegible text block]

()
()

()
()

Fig.9

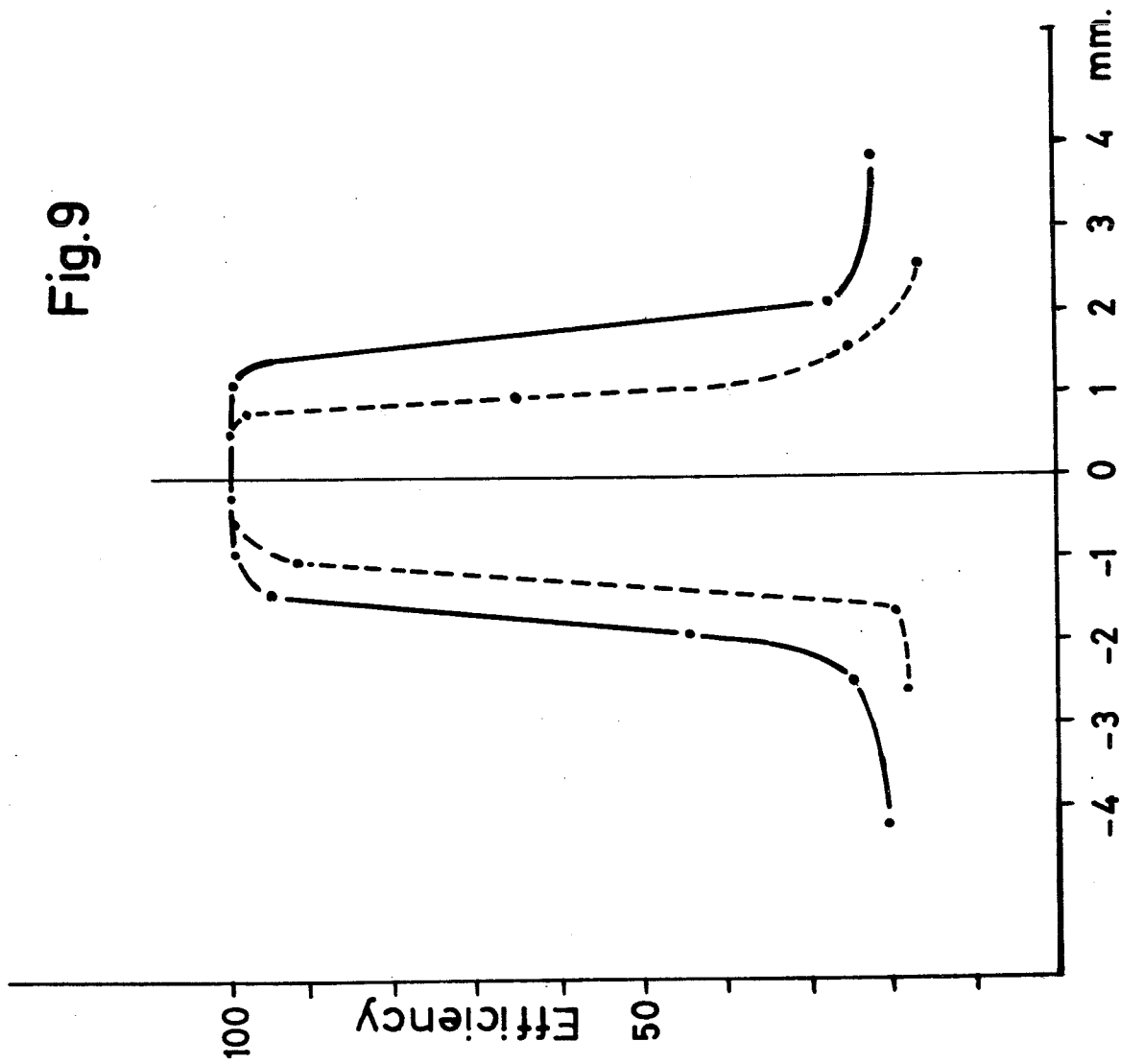

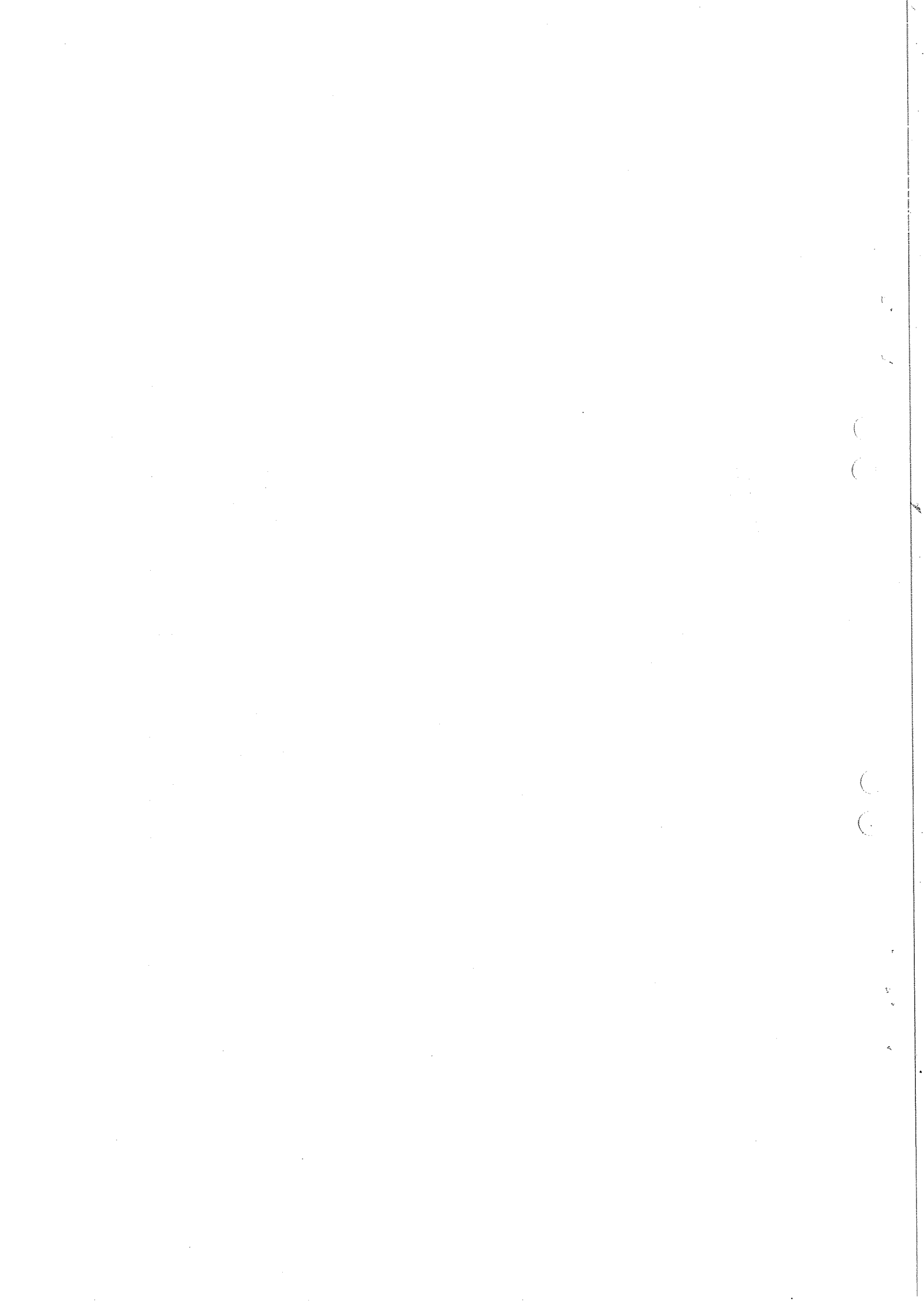

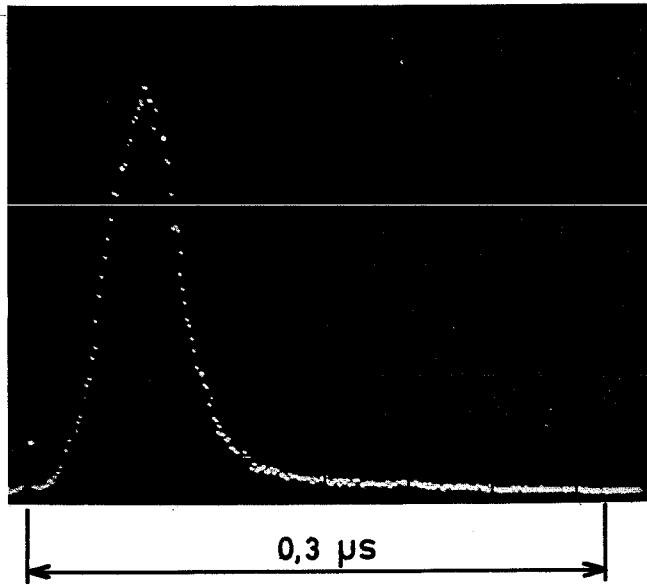

a

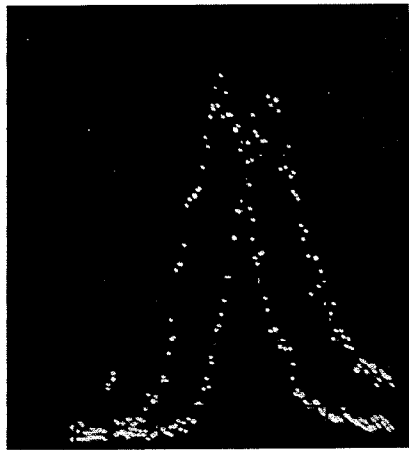

b

Fig. 10

1. The first part of the document discusses the importance of maintaining accurate records of all transactions. It emphasizes that this is crucial for ensuring the integrity of the financial statements and for providing a clear audit trail. The text also mentions that proper record-keeping is essential for identifying and correcting errors in a timely manner.

2. The second part of the document focuses on the role of internal controls in preventing fraud and misstatements. It highlights that a strong internal control system is necessary to ensure that all transactions are properly authorized, recorded, and reviewed. The text also notes that internal controls should be designed to be effective and efficient, and should be regularly evaluated and updated as needed.

3. The third part of the document discusses the importance of transparency and communication in financial reporting. It emphasizes that providing clear and concise information to stakeholders is essential for building trust and confidence in the organization's financial performance. The text also mentions that transparency is a key component of good corporate governance and is essential for attracting investment and financing.

4. The fourth part of the document discusses the importance of compliance with applicable laws and regulations. It emphasizes that organizations must ensure that their financial reporting practices are in full compliance with all relevant laws and regulations. The text also mentions that compliance is essential for avoiding legal and financial penalties and for maintaining the organization's reputation.

5. The fifth part of the document discusses the importance of continuous improvement in financial reporting. It emphasizes that organizations should regularly review and evaluate their financial reporting processes to identify areas for improvement and to ensure that they are always up-to-date and effective. The text also mentions that continuous improvement is essential for staying ahead of the competition and for ensuring long-term success.

1
2
3
4
5
6
7
8
9
10
11
12
13
14
15
16
17
18
19
20
21
22
23
24
25
26
27
28
29
30
31
32
33
34
35
36
37
38
39
40
41
42
43
44
45
46
47
48
49
50
51
52
53
54
55
56
57
58
59
60
61
62
63
64
65
66
67
68
69
70
71
72
73
74
75
76
77
78
79
80
81
82
83
84
85
86
87
88
89
90
91
92
93
94
95
96
97
98
99
100

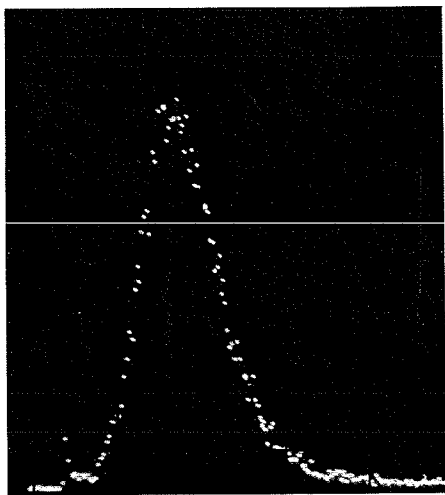

a

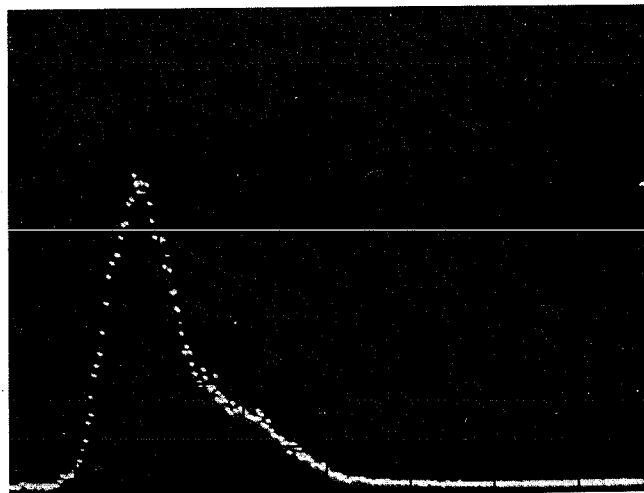

b

1 μ s.



c

Fig.11

100-100000-100000

()
()

()
()

100-100000-100000