

Commissioning Experience with the PEP-II Low-Level RF System*

P. Corredoura, S. Allison, R. Claus, W. Ross, L. Sapozhnikov, H. D. Schwarz, R. Tighe, C. Yee, C. Ziomek
Stanford Linear Accelerator Center, Stanford, Ca 94309, USA

Abstract

The low-level RF system for PEP-II is a modular design housed in a VXI environment and supported by EPICS. All signal processing and control is done at baseband using in-phase and quadrature (IQ) techniques. Remotely configurable RF feedback loops are used to control coupled-bunch instabilities driven by the accelerating mode of the RF cavities. A programmable DSP based feedback loop is implemented to control phase variations across the klystron due to the required adjustment of the cathode voltage to limit cathode power dissipation. The DSP loop also adaptively cancels modulations caused by klystron power supply ripple at selected power line harmonics between 60 Hz and 10 kHz. The system contains a built-in baseband network analyzer which allows remote measurement of the RF feedback loop transfer functions and automated configuration of these loops. This paper presents observations and measured data from the system.

1. INTRODUCTION

The PEP-II low-level RF (LLRF) system [1] is based on 6 types of custom VXI modules, an off-the-shelf slot 0 controller/processor and an Allen Bradley (AB) VME scanner (figure 1). The processor is a National Instruments 68030 running the VxWorks real-time operating system which is supported by EPICS. The AB scanner supports a serial communication link with the Allen Bradley hardware used for slow interlocks (temperatures, water flows, power supply monitoring), control of cavity tuner stepper motors and control of the klystron high voltage power supply (HVPS). The clock/RF distribution module generates the 471.1 MHz LO and digital system clocks. The arc/interlock module detects window arcs, VXI faults and handshakes with the HVPS triggers and beam abort system [3].

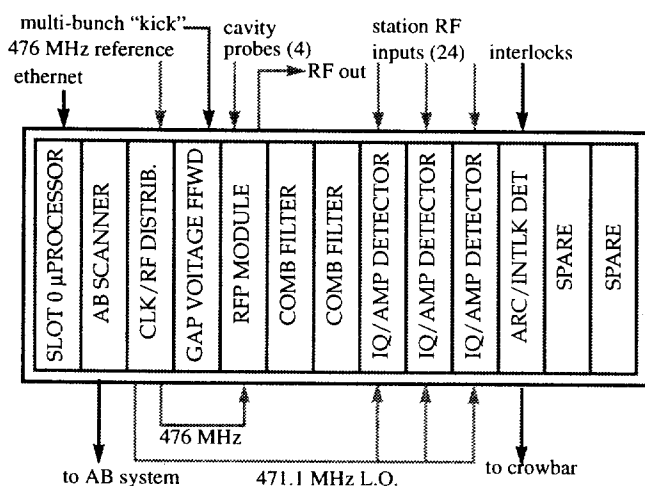

Fig. 1. PEP-II low-level RF system VXI crate topology

CERN LIBRARIES, GENEVA

*Work support
DE-AC03-76



SCAN-9708083

Swg735

The IQ&A detector modules are 8 channel RF receivers using a digital in-phase and quadrature (IQ) down conversion technique for precise narrow-band measurements and a parallel diode detector used for wide-band amplitude detection [5] required for fast RF interlocks. Narrow-band (50 Hz) IQ measurements are transmitted to the EPICS database at a 2 Hz rate for station RF displays and the "slow" feedback loops (cavity tuners and cathode voltage control). The klystron RF output is measured by a special IQ channel programmed for a 10 kHz bandwidth which transmits directly to the DSP in the RF Processing module via a VXI local bus serial link running at 23 kHz. This DSP executes a state space feedback loop across the klystron, drive amplifier, and RF modulator which keeps the phase shift across this path constant and cancels output phase and amplitude ripple caused by power line harmonics appearing on the HVPS output at a 1% level.

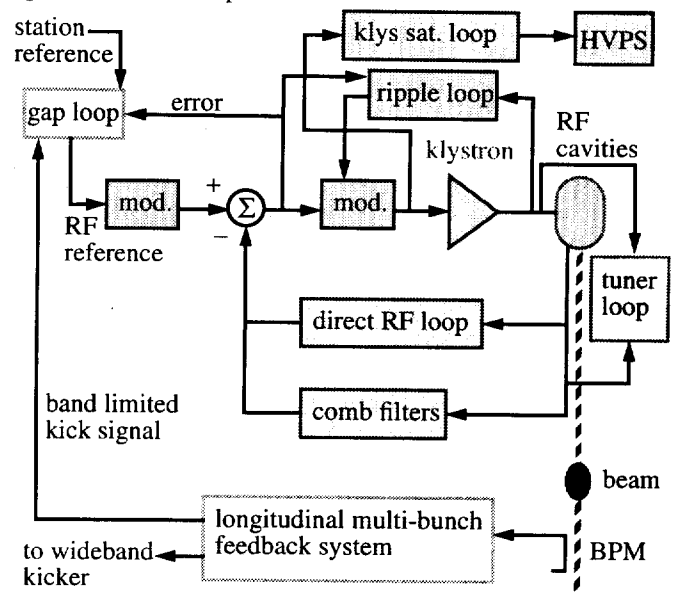

Fig. 2. Block diagram of RF feedback loops used in the PEP-II low-level RF system. Multi-cavities not shown for simplicity.

The RF Processing module (RFP) contains the hardware necessary to support the wideband RF feedback loops needed to control longitudinal coupled-bunch instabilities caused by the accelerating mode of the RF cavities. Analog IQ demodulators which have a bandwidth of >10 MHz are used to detect the RF voltage in each cavity. A programmable analog network allows combining the detected IQ signals from up to four cavities to form a station gap voltage vector sum signal. Programmable analog modulators allow remote adjustment of loop gains/phases for both direct and comb filter loops. A built in baseband arbitrary function generator/recorder forms a programmable network analyzer capable of performing initial cavity tuning, configuring the combining network, measuring RF feedback loop transfer functions and injecting test signals into the RF system. To our knowledge this feature is a first for storage ring RF systems and has proved to be extremely useful.

The comb filter modules operate in parallel with the direct RF feedback loop providing additional loop gain for a narrow band about the synchrotron sidebands covering the first ~30 revolution harmonics. A programmable 32 tap finite impulse response (FIR) filter is used to equalize the system group delay variation caused by the damped fundamental cavity resonance. The total comb loop delay is adjusted to equal exactly one ring revolution via a programmable FIFO. One module filters the in-phase (I) signal while the second filters the quadrature (Q) signal. A built-in history buffer which automatically stops when a system fault is detected records the comb filter output for the previous 7000 turns. The comb modules communicate with the RFP module via differential analog signals carried over the VXI local bus.

The last module of the PEP-II LLRF family is the gap voltage feed-forward module [2]. This module has two functions. It receives the error signals (I&Q) of the direct RF feedback loop from the RFP module (as VXI local bus differential analogs) and generates the station baseband IQ reference through an adaptive learning algorithm. The resulting station references (I&Q) track the RF cavity transients caused mainly by the ion clearing gap in the bunch train and prevent the klystron from saturating. These calculations are performed on a dedicated DSP. The second function of this module is to modulate the station RF reference by a band-limited "kick" signal sent from the PEP-II longitudinal multi-bunch feedback system. The "kick" is sent via a dedicated fiber optic link which transmits 10 bits of information at a 10 Ms/S rate. As with the comb filters, the kick signal is equalized by a 32 FIR filter and delayed with a FIFO to make the total group delay equal to two ring turns. The type of modulation resulting from the kick is programmable via a look-up table but will probably be a phase modulation. Hardware in this module and in the longitudinal system kick source allow remote measurement of the "kick" transfer function for each RF station. The resulting IQ station reference is delivered to the RFP module as differential analog signals over the VXI local bus.

2. SYSTEM CONFIGURATION

The process of setting up a PEP-II RF station is quite involved. Through the use of the built-in measurement capability and the complete programmability of all adjustment parameters, this process has been highly automated. Matlab scripts running on a workstation have been written to access the EPICS database, control the necessary hardware and perform the substantial amount of signal processing required to configure the system. The procedure for bringing up a station is as follows:

TUNE RF CAVITIES - Klystron drive power is set to 25% of the saturated level to allow for the addition of band limited noise to the drive signal. The station is turned on at 100 kW klystron output power. The built-in network analyzer is used to measure the transfer function of each cavity. This measurement is fit to a model and the center frequency is extracted. The required cavity tuner movement is calculated and implemented. This process repeats for each cavity until all cavities are within 10 kHz of 476 MHz. We have found that variations in the cavity supply water temperature of 1°C prevent us from

getting any closer without using the tuner loop. Next the tuner loop phase offsets are nulled and the tuner loop is activated. Cavity frequency measurements are repeated but adjustments are now made to the cavity probe phase offset. Drift in the water temperature no longer causes a frequency shift. This procedure is capable of bringing each cavity to within 300 Hz of the system RF frequency (476 MHz), corresponding to an acceptable 1° error in the cavity transmission phase. The cavity combining network in the RFP is then adjusted to null out phase variations caused by differences in cable lengths, sum the cavity voltages while conserving any gap voltage variations observed in the set of cavities due to variations of cavity Q and β . All cavities are now tuned, tuner loop phase offsets nulled and the combining network is optimized. This process takes about 30 minutes.

CONFIGURE DIRECT RF FEEDBACK LOOP - To insure a constant phase shift across the klystron the "ripple" loop must be enabled. Otherwise changes in the HVPS output voltage would translate to a change in the loop phase of the direct RF feedback loop. An automatic gain control (AGC) loop is planned which will keep the large signal gain of the klystron and the ripple loop modulator constant as the HVPS voltage is varied. To set the gain and phase shift of the direct loop the built-in network analyzer is again used to measure the open loop response. The measured response is fit to a model and the adjustment required to obtain phase margins of 67° (determined to be the optimum) is calculated. After updating the direct loop modulator the open loop response is again measured to verify that the proper settings have been achieved. If the response is OK the loop is closed and the closed loop response is measured. This procedure takes 10 minutes.

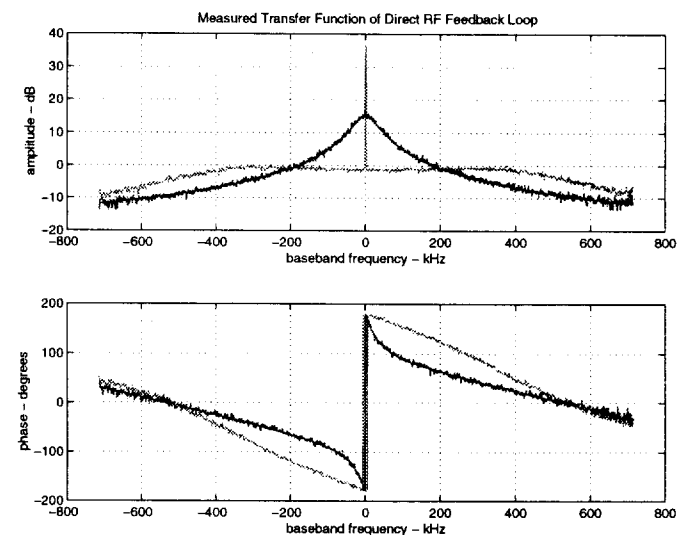

Fig. 3. Measured open/closed loop response of the direct loop.

CONFIGURE THE COMB FILTER LOOP - Since the comb loop operates in parallel with the direct loop, the direct loop must be operating before the comb loop can be set up. The first step is to determine the group delay equalizer tap settings. The comb filters are placed in "thru" mode (no filtering) and equalizer taps are loaded with a single full scale tap weight, the remaining 31 taps are set to zero. The network analyzer then measures the open loop response of the comb filter path. The

response information is used to calculate the necessary tap weights to equalize the delay and roll the gain off above 2.5 MHz. The new taps are loaded and the equalized response is measured (figure 4). Next the comb filters are activated and the open loop response is measured. The response covering the first few comb peaks is fit to a model and the desired comb modulator coefficients are determined and loaded. The open loop response is then verified. If the open loop response is acceptable the loop is closed. The closed loop response (reflecting the damped cavity impedance) is then measured.

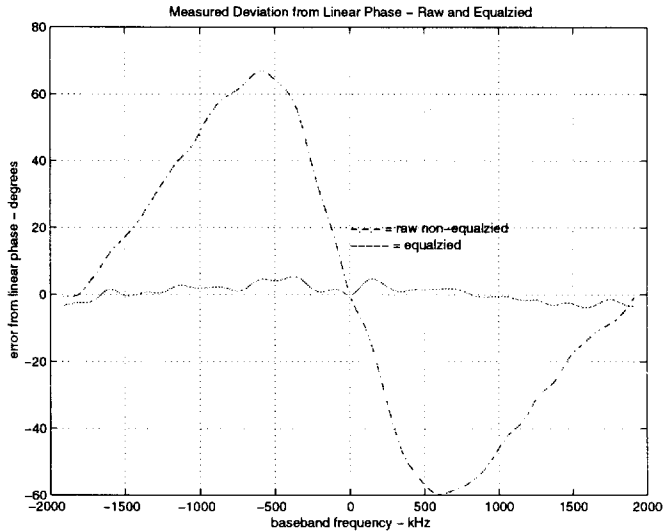

Fig. 4. Measured response of system without/with equalization.

3. KLYSTRON "RIPPLE" LOOP

To correct for DC phase variations across the klystron and cancel output modulation caused by HVPS output ripple a feedback loop using state-space control and adaptive noise cancellation techniques has been developed [6]. This new approach has several advantages over a typical klystron phase loop used in most storage rings. Mainly this method is completely compatible with IQ signal processing and does not require addition of analog phase detectors. The loop runs on a AT&T 1610 DSP in the RF processing module. The DSP receives band limited (10 kHz) klystron output RF data (I&Q) at a 23 kHz rate from a dedicated channel of an IQ&A detector module via a dedicated serial link. The DSP also measures the I&Q baseband drive signals using two 12 bit ADCs. The design of this loop has been described previously [1].

The current version of this loop keeps the phase shift across the RF modulator, drive amplifier and the klystron constant while cancelling both AM and PM from 14 sinusoidal noise sources. This number is limited by the amount of computations to be carried out before the next data sample arrives (every 43 μs). Most of the processor time is used calculating the inverse tangents (drive phase and klystron output phase) and the square root (klystron output amplitude). We expect to increase the number of harmonics allowed by writing a new arctan function which is limited to 10 bits of precision, the current arctan supports 36 bits. During initial testing of this loop we were able to maintain the phase length of the drive chain and klystron to within 1° and reduce the amplitude of the targeted sidebands by ~30dB.

4. STATION OPERATION

Operator interface to the PEP-II RF system is achieved via EPICIS panels [4]. The main RF panel (figure 5) displays the most important system parameters (klystron and cavity RF power, gap voltages, vacuum levels, cavity tuner positions), has "buttons" for controlling the station mode and accessing other more detailed panels. Because of the system's complete programmability we have been able to add features which significantly reduce the required amount of operator involvement. Each station is capable of "autoprocessing". The user sets up the desired processing endpoints (maximum klystron power, maximum cavity voltage and vacuum level) and the EPICIS processor will ramp the power up until the warning vacuum level is reached, power is then reduced. This procedure continues until the desired maximum set points are reached. To process new (dirty) cavities a method of sweeping the drive frequency +/- 160 kHz has been implemented by loading FM IQ files into the built-in network analyzer's programmable source. The system can also of reset itself after a fault.

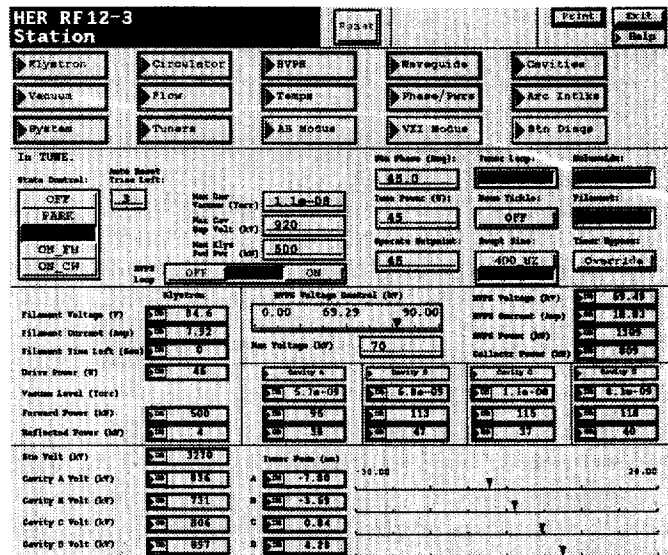

Fig. 5. Main EPICIS panel for a PEP-II RF station.

5. REFERENCES

- [1] P. Corredoura et al, "Low Level System Design for the PEP-II B Factory", Proceedings of the 1995 IEEE Particle Accelerator Conference.
- [2] W. Ross, R. Claus, L. Sapozhnikov, "Gap Voltage Feed-Forward Module for the PEP-II Low-Level RF System", this conference (PAC 97)
- [3] R. Tighe, "Arc Detection and Interlock Module for the PEP-II Low Level RF System", PAC 97
- [4] S. Allison, R. Claus, "Operator Interface for the PEP-II Low Level RF Control System", PAC 97
- [5] C. Ziomek, P. Corredoura "Digital I/Q Demodulator", Proceedings of the 1995 IEEE Particle Accelerator Conference.
- [6] P. Corredoura "Development of Digital Control for the PEP-II Klystrons", SLAC PEP-II Tech Note #60, 1994.
- [7] Thanks to Khoi Ha of Hytek Services for providing us with superior printed circuit board layout design support.