



Lawrence Berkeley Laboratory

UNIVERSITY OF CALIFORNIA

Accelerator & Fusion Research Division

Presented at the Cryogenic Engineering Conference,
Columbus, OH, July 17-21, 1995, and to be published
in the Proceedings

Cryogenic Tests of the g-2 Superconducting Solenoid Magnet System

L.X. Jia, J.R. Cullen Jr., A.J. Esper, R.E. Meier, C. Pai,
L. Snyderstrup, T. Tallerico, and M.A. Green

July 1995



CERN LIBRARIES, GENEVA

5089609

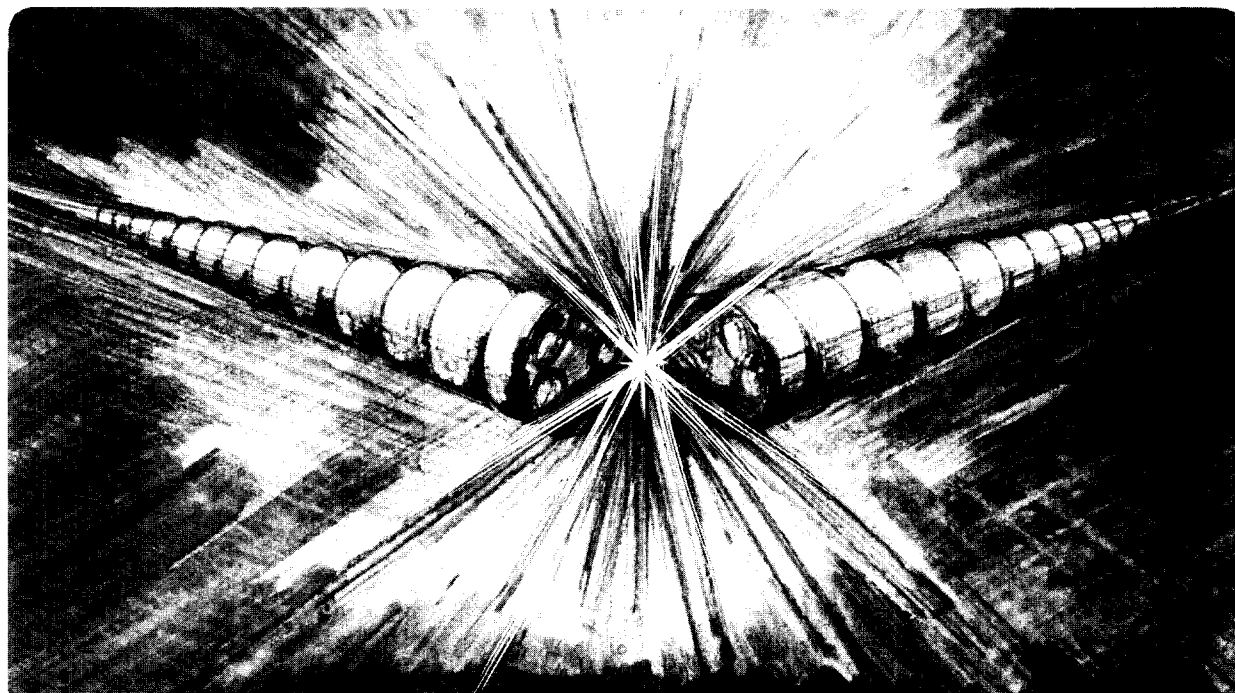

DISCLAIMER

This document was prepared as an account of work sponsored by the United States Government. While this document is believed to contain correct information, neither the United States Government nor any agency thereof, nor The Regents of the University of California, nor any of their employees, makes any warranty, express or implied, or assumes any legal responsibility for the accuracy, completeness, or usefulness of any information, apparatus, product, or process disclosed, or represents that its use would not infringe privately owned rights. Reference herein to any specific commercial product, process, or service by its trade name, trademark, manufacturer, or otherwise, does not necessarily constitute or imply its endorsement, recommendation, or favoring by the United States Government or any agency thereof, or The Regents of the University of California. The views and opinions of authors expressed herein do not necessarily state or reflect those of the United States Government or any agency thereof, or The Regents of the University of California.

Ernest Orlando Lawrence Berkeley National Laboratory
is an equal opportunity employer.

CRYOGENIC TESTS OF THE g-2 SUPERCONDUCTING SOLENOID MAGNET SYSTEM

**L. X. Jia, J. R. Cullen Jr., A. J. Esper, R. E. Meier C. Pai,
L. Snydstrup and T. Talerico,**

Brookhaven National Laboratory
Upton, NY 11973

M. A. Green

E. O. Lawrence Berkeley National Laboratory
University of California
Berkeley, CA 94720

July 1995

* This work was performed at the Lawrence Berkeley Laboratory and at Brookhaven National Laboratory with the support of the Director of the Office of Energy Research, Office of High Energy and Nuclear Physics, High Energy Physics Division, United States Department of Energy under BNL contract number DE-AC02-76CH00016 and LBL contract number DE-AC03-76SF00098.

CRYOGENIC TESTS OF THE g-2 SUPERCONDUCTING SOLENOID MAGNET SYSTEM

L. X. Jia, J. R. Cullen Jr., A. J. Esper, R. E. Meier, C. Pai,
L. Snyderstrup and T. Tallerico,

Brookhaven National Laboratory
Upton, NY, 11973

M. A. Green

E. O. Lawrence Berkeley National Laboratory
University of California
Berkeley, CA 94720

ABSTRACT

The g-2 muon storage ring magnet system consists of four large superconducting solenoids that are up to 15.1 m in diameter. The g-2 superconducting solenoids and a superconducting inflector dipole will be cooled using forced two-phase helium in tubes. The forced two-phase helium cooling will be provided from the J-T circuit of a refrigerator that is capable of delivering 625 W at 4.5 K. The two-phase helium flows from the refrigerator J-T circuit through a heat exchanger in a storage dewar that acts as a phase separator for helium returning from the magnets. The use of a heat exchanger in the storage dewar reduces the pressure drop in the magnet flow circuit, eliminates most two phase flow oscillations, and it permits the magnets to operate at variable thermal loads using the liquid in the storage dewar as a buffer. The g-2 magnet cooling system will consist of three parallel two-phase helium flow circuits that provide cooling to the following components; 1) the four large superconducting solenoids, 2) the current interconnects between the solenoids and the solenoid gas cooled electrical leads, and 3) the inflector dipole and its gas cooled electrical leads. This report describes a cryogenic test of the two 15.1 meter diameter superconducting solenoids using two-phase helium from a dewar. The report describes the cool down procedure for the 3.5 ton outer solenoid magnet system using liquid nitrogen and two-phase helium. Low current operation of the outer solenoids is discussed.

THE g-2 STORAGE RING MAGNET SYSTEM

An experiment to measure the value of g-2 for the muon has been under construction at the Brookhaven National Laboratory in Upton New York since 1988^{1,2,3}. The g-2 experiment magnet system consists of three large superconducting solenoid magnets that form a storage ring, a superconducting inflector magnet for injecting the muon beam into the storage ring, and a string of conventional bending and quadrupole magnets that are used

to carry a decaying pion beam from a fixed target at the Brookhaven 33 GeV Alternating Gradient Synchrotron (AGS) to the storage ring that is located in a building some distance from the AGS.

The storage ring consists three large indirectly cooled superconducting solenoids wound with an aluminum stabilized superconductor. There are two 24 turn inner solenoids that have a coil diameter of 13.4 meters and a single 48 turn outer solenoid that has a coil diameter of 15.1 meters. The three solenoids are the largest diameter superconducting solenoids that have been built to date. The current in the two inner solenoids will be run in opposition to the current in the outer solenoid creating the storage ring dipole field. An iron return yoke in the shape of a C returns the magnetic flux. Separate iron pole pieces control the quality of the 1.451 tesla induction within the gap. The integrated induction around the storage ring must be good to 1 ppm within a 90 mm diameter region that contains the muon beam⁴. Focusing for the storage ring is supplied by electrostatic quadrupoles mounted within the storage ring beam vacuum chamber.

The open part of the C points toward the center of the storage ring so the electrons that result from the decay of the muons (muons at rest have a decay half life of about 0.06 ms) will spiral inward to the detectors for the experiment. The beam enters the storage ring from the outside through a hole in the C shaped iron return leg and outer solenoid between the two 24 turn coils that are mounted on the outer solenoid cold mandrel. A cross-section of the g-2 storage ring magnet showing the three solenoids is shown in Fig. 1. A photo of the nearly completed g-2 storage ring is shown in Fig. 2

At the ring entrance, a superconducting DC inflector⁵ will locally cancel the field of the main storage ring magnet so that the muon beam enters, as closely as possible, tangentially to the equilibrium orbit of the storage ring. The inflector magnet is designed to "eat" its own flux so that stray field from the inflector is greatly reduced. In addition the inflector has a superconducting shield so that virtually all of the remaining stray field from the inflector is eliminated. Thus, the inflector has no influence on the field in the gap.

Construction of the g-2 solenoids and their cryostats is complete. The outer solenoid has been mounted on the lower part of the iron yoke. The iron back leg of the C and the upper part of the iron yoke has been mounted around the outer solenoid cryogenic vacuum vessel. The two inner solenoids have been mounted on the C shaped iron yoke to form a continuous storage ring dipole as shown in Fig 1. The basic mechanical and electrical parameters of the three solenoid storage ring magnet system is given in Table 1.

Table I Parameters of the g-2 Solenoid Magnets in the Iron Return Yoke

Iron Height (mm)	1570.
Iron Width (mm)	1394
Total Iron Mass for the Ring (metric tons)	681.6
Number of Solenoid Packages	3
Inner Solenoid Coil Radius (m)	6.70
Outer Solenoid Coil Radius (m)	7.55
Pole Width (mm)	560.0
Nominal Gap between the Poles (mm)	180.0
Nominal Beam Bend Radius (m)	7.112
Good Field Region Diameter (mm)	90.0
Dipole Central Induction (T)	1.451
Inner Solenoid Number of Turns (each)	24
Outer Solenoid Number of Turns	48
Coil Current* (A)	5300
Magnet Self Inductance (H)	0.39
Storage Ring Dipole Stored Energy* (MJ)	5.50
Total Solenoid Cold Mass (metric tons)	~6.2

* at the design central induction

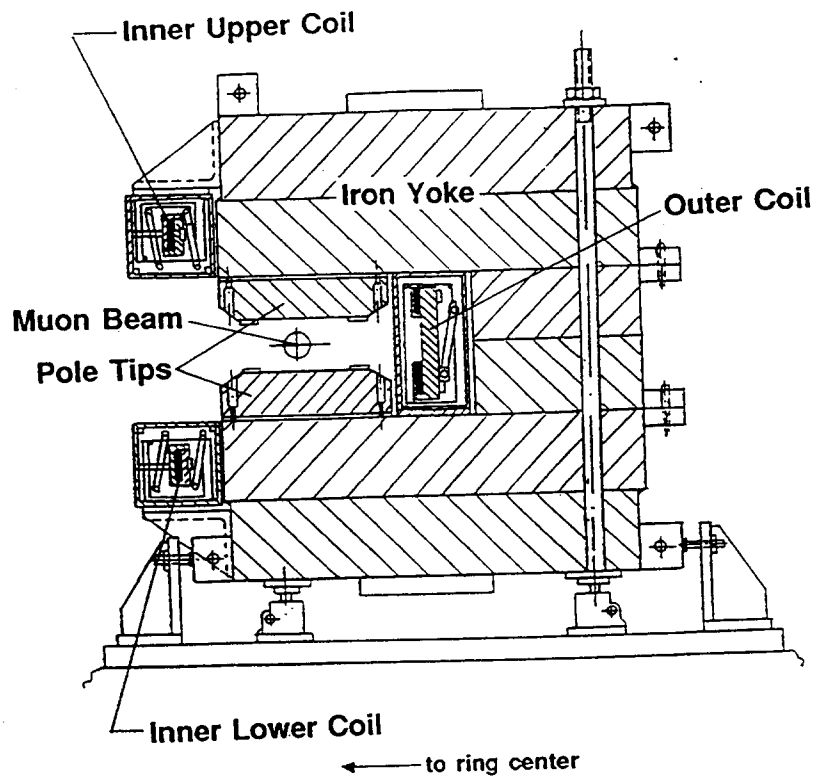

Fig. 1 A Cross-section of the g-2 Storage Ring Bending Magnet Showing the Location of the Three Large Superconducting Solenoid Magnets

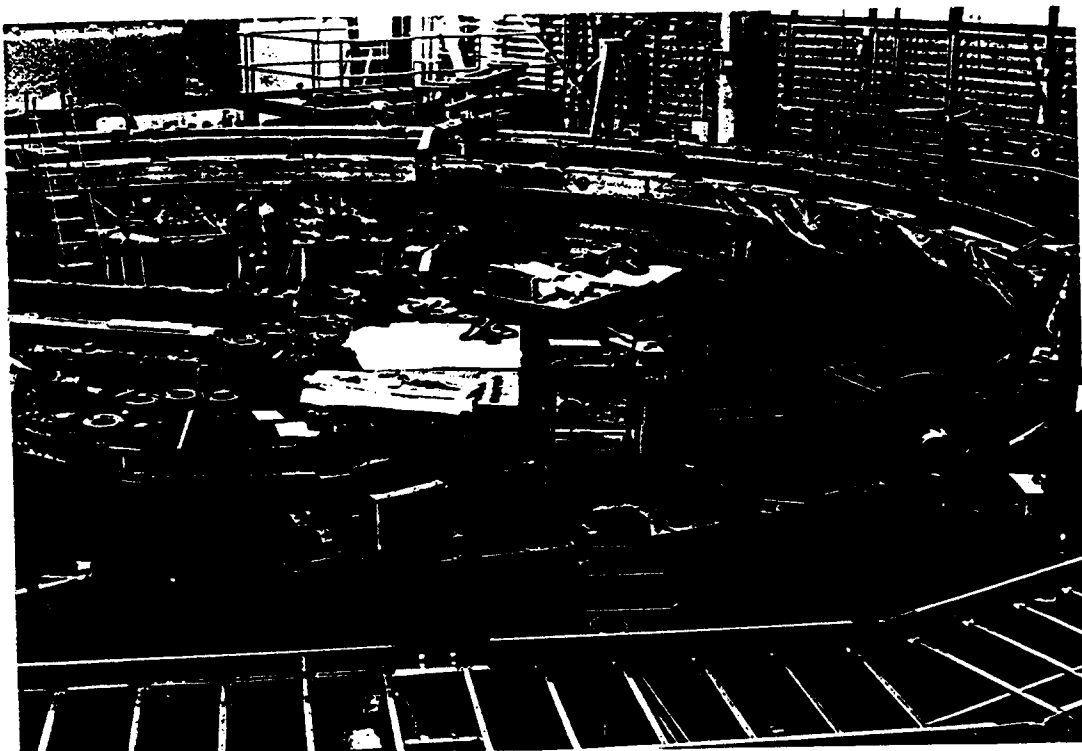

Fig. 2 The g-2 Storage Ring (June 1995) before the Electron Detectors were Installed inside of the Storage Ring

CRYOGENIC TEST OF THE OUTER SOLENOID

Since the outer solenoid is to be buried within the C shaped iron yoke, a cryogenic test of the outer solenoid coil package was performed before the outer solenoid cryostat was buried. The refrigerator, which had been previously tested, was not available for cooling the outer solenoid down to liquid helium temperature. It was decided that the outer coil cold mass (about 3.5 metric tons) could be cooled down using cold nitrogen gas, then liquid nitrogen, and finally liquid helium. This cool down was done in the winter of 1995.

The liquid nitrogen and liquid helium was transferred from liquid dewars. The mandrel of the outer solenoid is cooled by cryogen that flows through an aluminum tube that is welded to the mandrel. The superconducting coil is indirectly cooled by conduction from the mandrel. The inside dimensions of this cooling tube is 11.1 mm by 30.1 mm. The effective diameter of an equivalent round tube is 20.6 mm, but the hydraulic diameter of this tube is only 16.2 mm. (The hydraulic diameter is always smaller than the equivalent round tube diameter for a rectangular flow tube.) The length of the tube attached to the mandrel is about 96 meters. The cooling tube makes two turns around the outer coil mandrel. There is good thermal conduction between the tube and between the entrance and exit of the tube. As a result, during the cool down, the lowest mandrel temperature is right at the cryogen entry point. The high temperature point on the mandrel was on the opposite side of the solenoid about 190 degree from the fluid entry point.

The nitrogen cooled shield has two cooling tubes in parallel. The nitrogen makes a single turn around the solenoid shield. Unlike the solenoid mandrel, the shield high temperature point is at the exit point of the nitrogen circuit (during the cool down). The reason for this is that the shield must be broken electrically to prevent circulating currents from flowing in the shield during a magnet quench. At the electrical break in the shield, the two pieces are attached through a small tab of fiber glass epoxy composite. This insulator is also a poor conductor of heat so the shield high temperature point occurs very close to the nitrogen exit point. The fact that the temperature distribution in the shield is different than the temperature distribution in the mandrel during the magnet cool down causes the screws that attach the shield to the mandrel to be stressed. It is likely that a number of these screws broke during the solenoid cool down despite trying to keep the shield temperature within 25 K of the mandrel temperature.

The outer coil was cooled from room temperature (294 K) to about 150 K using warm nitrogen gas mixed with liquid nitrogen boil off gas. At some point when the mandrel temperature was below 150 K, liquid nitrogen was used to cool the coil down to 80 K. It took about 115 hours to cool the outer coil package from 294 K to 80 K. (See Figure 3) The driving pressure during the liquid nitrogen phase of the cool down was less than 0.2 MPa (30 psi) The coil cool down from 80 K to the point where the outer coil became superconducting used liquid helium from dewars to provide the cooling. Through most of this phase of the cool down, the sensible heat of the helium was used along with the heat of vaporization. It took 135 hours to cool the coil from 80 K until the magnet was superconducting

The conductor used in the g-2 solenoid is about 19 parts ultra pure aluminum, 1 part copper and 1 part Nb-Ti. The stabilizing aluminum (99.999 percent pure) has a residual resistance ratio RRR (the resistance at 273 K divided by the resistance at 4 K) of 2000 to 2500 before the conductor was wound into the coil. At low temperature, the resistance of the conductor is strongly dominated by the aluminum. At room temperature the coil resistance was about 0.95 ohms. The resistance of the coil dropped about a factor of 10 as the coil cooled from 294 K to 80 K. The coil resistance dropped another factor of 220 as the coil cooled from 80 K to 10 K. The RRR of the ultra pure aluminum matrix material has remained above 2000 despite the cold work induced in the conductor during winding. Figure 4 shows the outer solenoid resistance as a function of the average mandrel temperature (as determined by several thermometers on the mandrel). As the average mandrel temperature dropped below 9.5 K, the outer solenoid coil became superconducting. The coil was fully superconducting when the average mandrel temperature reached 8.7 K. (The critical temperature of Nb-Ti is about 9.4 K.)

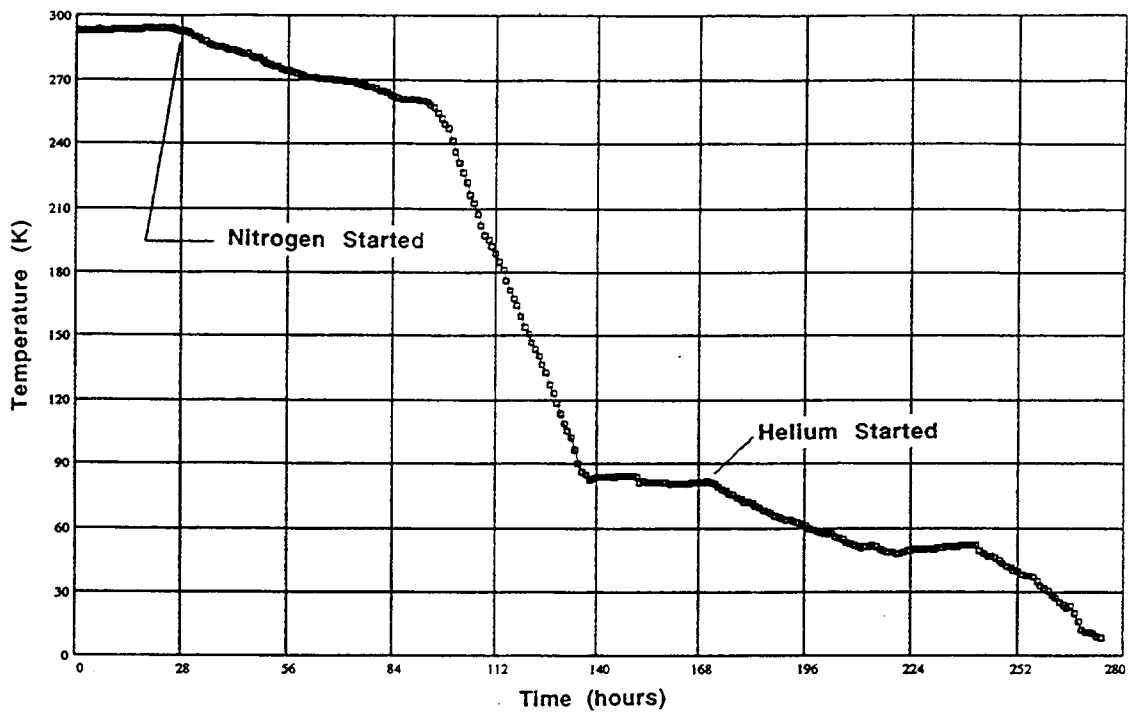

Fig. 3 The Average Temperature of the g-2 Outer Solenoid Mandrel as a Function of Time During a Cool Down Using Nitrogen and Liquid Helium from Dewars

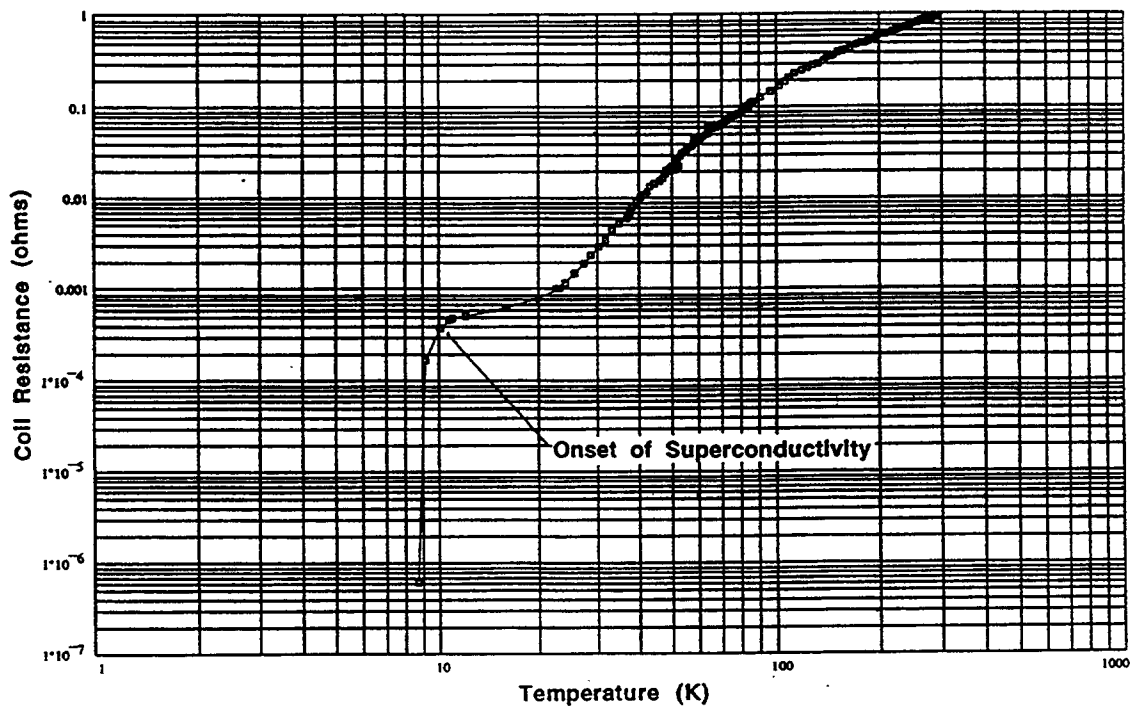

Fig. 4 The Outer Solenoid Coil Resistance as a Function of the Average Mandrel Temperature as Measured during a Liquid Nitrogen and Helium Cool Down

The lowest temperature achieved in the outer coil was about 7 K. At that point, the liquid helium supply was exhausted. All during the magnet cool down, the cryostat vacuum was monitored for leaks. The cryostat vacuum remained good even when there was liquid helium within the cooling circuit, as expected. The heat leak into the outer solenoid mandrel was measured to be a little over 50 watts. Since the cold mass supports carry about 3.5 metric ton and the cryostat area is about 70 square meters, this value is consistent with the heat leak calculations.

Since the outer solenoid cryostat is encased in the C shaped iron return yoke, the clearance between the cryostat vacuum vessel and the pole is an issue. The minimum clearance between the pole and the cryostat vacuum vessel (about 6.4 mm) limits the minimum temperature allowed for the outer solenoid cryostat vacuum vessel. This vacuum vessel temperature should always be kept above 260 K. Calculations show that the vacuum vessel wall can drop below this temperature if the vacuum is broken by helium gas at 0.1 MPa. An air leak into the vacuum vessel will result in a vacuum vessel wall temperature that is greater than 270 K. Measurements of the vacuum vessel temperature when the vacuum was broken with helium appear to agree with the calculated temperatures for the wall. The calculations indicate that the vacuum wall temperature will never reach 260 K with helium in the vacuum space, provided the helium pressure in the cryostat vacuum vessel is kept below 3 kPa (about 23 torr).

CONCLUSION

Fabrication of the three large solenoids for the g-2 storage ring is complete. The three solenoids have been assembled into the iron return yoke. The outer solenoid magnet was successfully cooled down using liquid nitrogen and liquid helium. The outer solenoid became superconducting. The RRR of the conductor in the outer solenoid remained above 2000 despite the limited cold work that occurred in the matrix during winding. The refrigerator that will be used to cool down the experiment has been tested. It should deliver 625 watts when the compressor input flow is 100 grams per second at 1.8 MPa. A cool down of the three solenoids using the refrigerator will occur in the summer of 1995. The solenoid will be powered in the fall of 1995.

ACKNOWLEDGMENTS

This work was performed at the Lawrence Berkeley Laboratory and at Brookhaven National Laboratory with the support of the Director of the Office of Energy Research, Office of High Energy and Nuclear Physics, High Energy Physics Division, United States Department of Energy under contract number DE-AC02-76CH00016 and contract number DE-AC03-76SF00098.

REFERENCES

1. "Muon g-2 Design Report," Brookhaven National Laboratory, Upton NY 11973, AGS 821, April 1994
2. The g-2 Collaboration, "The g-2 Storage Ring Superconducting Magnet System," IEEE Transactions on Magnetics MAG-30, No. 4, p 2423 (1994)
3. G. Bunce et al., "The Large Superconducting Solenoids for the g-2 Ring," to be published in IEEE Transactions on Applied Superconductivity 5, No. 2 (1995)
4. G. T. Danby and J. W. Jackson, "Shimming Techniques for the Ultraprecise Muon g-2 Storage Ring at the AGS, IEEE Transactions on Magnetics MAG-30, No. 4, p 1710 (1994)
5. F. Krienen et al., "The Superconducting Inflector Dipole for the g-2 Muon Storage Ring," to be published in IEEE Transactions on Applied Superconductivity 5, No. 2 (1995)