



EUROPEAN ORGANIZATION FOR NUCLEAR RESEARCH

ISR-DI/67-63

Paper presented to the Vth International Conference
on High-Energy Accelerators
Cambridge, Mass.

THE CERN INTERSECTING STORAGE RING PROJECT

by

K. Johnsen

Geneva, 6 September, 1967

1. General Description

At the last International Accelerator Conference in 1965 at Frascati, I was very happy to be able to announce that the CERN Council had a few months earlier approved in principle the plan to construct a set of proton intersecting storage rings (ISR) attached to the CERN proton synchrotron. The Council followed this up by allocating in December of the same year the funds necessary for the construction. This project is therefore now about 1 1/2-2 years into the construction period. The responsibility within CERN for this project lies with the ISR Construction Department, which was specially formed for this purpose, but which is effectively a continuation of the former Study Group. It has grown from about 60 people two years ago to 175 now.

Almost everybody at this conference is acquainted with the project from various descriptions given at earlier conferences. Nevertheless, for the benefit of the newcomers and for those who have forgotten, I will start by a very short general description.

The great interest in colliding beam devices lies in the very high attainable interaction energy. The CERN-PS delivers protons up to 28 GeV. Head-on collisions between such protons would mean 56 GeV c.m. energy, whereas the same protons against a stationary target would only give 7.5 GeV c.m. energy. To reach 56 GeV c.m. energy with an ordinary accelerator would require an accelerator energy of more than 1600 GeV.

A simplified lay-out of how the ISR will provide for this possibility is shown in Fig. 1. After the particles have been accelerated in the CPS, they will be ejected by a fast kicker into the beam transfer line leading to the ISR. The pulses will be guided alternately into one or the other of the two branches, according to which of the two rings we want to fill. The two rings have alternating gradient focusing and the magnets look rather similar to proton synchrotron magnets.

A fast injection system places each pulse from the CPS near the inner wall of the vacuum chamber of the appropriate ring, where the particles are being picked up by an R.F. accelerating system and accelerated to near the outside wall of the chamber. The cavities are then switched off and the whole system is ready for the next pulse.

Several hundred CPS pulses can, in this way, be accumulated in each of the two rings, resulting in very intense circulating proton beams. The two rings are somewhat distorted so as to cross in eight intersecting points, and it is around these points that colliding beam experimentation can take place. Two of the intersecting areas will be equipped with special experimental halls from the beginning, but it will also be possible to carry out some experimentation around the other ones, as the tunnel is rather wide.

This project, in addition to providing for a p-p colliding beam facility, also provides for extensions and more flexibility for conventional physics with the CPS beam. A large new experimental area is being built for this purpose north-west of the ISR, and beams can either reach this area via an ejection system on one of the ISR rings or directly from the CPS via a tunnel by-passing the ISR. The former possibility will give extremely good flexibility of duty cycles and average intensity. The latter possibility is being provided in order to enable us to run experiments in the West Area while the ISR is unoperative (e.g. during installation of colliding beam experiments) or is being run for colliding beam experimentation.

The main parameters are presented in Table I. Comparing this with earlier conference papers one sees considerable changes since the early stages of the project studies. However, there are very few changes since the conference two years ago at Frascati. At that time there was still a lively discussion on the crossing angle, and intensive studies resulted in a few alternative solutions, in particular a structure giving 9° crossing angle. From a machine design point of view this was perhaps the best one. It was nevertheless concluded to stick to the 15° crossing angle as the one giving the best overall flexibility for experimentation.

TABLE I

ISR Parameter List

Max. total energy	E_{\max}	28 GeV
Average radius	R	150 m
Intersection angle	α	15°
No of magnet periods	N	48
No of superperiods	S	4
No of intersections		8
Long s.s. length		16.8 m
Q value	Q	8.75
Max. horizontal β value	$\beta_H \max$	41 m
Max. vertical β value	$\beta_V \max$	51 m
Max. momentum compaction	$\alpha_p \max$	2.3 m
No of magnets per ring		132
Max. field	B_0	1.2 T
Bending radius	ρ	78.5 m
Profile parameter	n/ρ	3 m^{-1}
Gap height		0.1 m
Harmonic number	h	30
R.F. volts per turn	50 V to	20 kV
Design pressure		10^{-9} torr
Vac. chamber dimensions	16 x	5.2 cm^2

2. Expected Performance

It is often claimed that one of the weakest points of colliding beam devices, from the point of view of carrying out good elementary particle physics, is the intensity and, somewhat related to that, the signal-to-background ratio. We are, therefore, watching this aspect of the ISR project continuously.

There has recently been some interesting development on this front, and a separate paper¹⁾ is being delivered to the conference on this subject. I shall here only give a summary of the most important factors.

The estimates based on present-day performance of the CPS and normal R.F. stacking indicate a luminosity of each of the eight interaction regions of

$$L = 10^{34} \left(\frac{\Delta p}{p} \right)^2 \text{ cm}^{-2} \text{ sec}^{-1} ,$$

where $\Delta p/p$ is the relative momentum spread acceptable by experimental conditions or by the aperture, whichever is the lowest. Typically, the aperture would accept $\Delta p/p \approx 2 \times 10^{-2}$ corresponding to about 20 A stacked current in each ring.

The planned improvement programme for the CPS aims at a factor of ten in increased intensity per CPS pulse. The first obvious advantage of this is that it will reduce the filling time of the ISR to its design current by this same factor, which will be particularly useful if the beam life time should have been overestimated.

How much the ISR intensity itself will increase from the CPS improvement programme depends on the beam properties from the improved CPS. Up to a short time ago we were rather concerned about longitudinal phase space blow-up due to space charge forces at transition. Such blow-ups were observed on the CPS at less than 10^{12} particles. Methods to suppress this have, however, been invented²⁾. This, together with further development of the relevant theory, has made us hopeful that transition blow-up can be avoided up to the

planned CPS intensities. If that should become true, nearly the whole increase in CPS intensity can be used to increase ISR intensity. Consequently, one is justified in hoping for a luminosity of

$$L = 0.8 \times 10^{36} \left(\frac{\Delta p}{p} \right)^2 \text{ cm}^{-2} \text{ sec}^{-1} ,$$

when the new CPS injector comes into operation, i.e. after 1972.

Moreover, Keil³⁾ has made the observation that if one assumes that one is able to stack both in longitudinal phase space and in transverse phase space, one can reach considerably higher intensities than with the stacking scheme originally planned for the ISR, in particular for experiments requiring $\Delta p/p \ll 2 \times 10^{-2}$. Courant, Keil and Sessler have pointed to methods for achieving this, and for further details I refer to their paper¹⁾.

The methods proposed would require solutions to very difficult technical problems, but there is nevertheless considerable hope that it will be possible, in the future, to take advantage of some of the potentialities exhibited by these methods. They all involve a relative shifting of parts of the beam, either at injection into the ISR or from the new injector into the CPS, or both, to give a beam superposition in longitudinal phase space. The superimposed parts must then occupy different regions of transverse phase space. This results in some R.F. buckets getting more densely populated while others stay empty. A method of stacking in the ISR with suppressed buckets has been developed by Schnell to avoid empty buckets diluting the already stacked beam⁴⁾.

Improvements in luminosity of another order of magnitude may be obtainable by such methods, in particular for low $\Delta p/p$ experiments. However, since the new injector for the CPS will not be available till 1972 and since the methods mentioned above require rather difficult new techniques, we consider this type of improvement to belong to the future. It nevertheless illustrates the kind of improvement programme one can see for the ISR when they have been well run in and established themselves in physics.

Another aspect should be mentioned that is important in all improvement considerations and that is the improvement in signal-to-background ratio that goes with the increased luminosities. This improvement is much slower than the improvement in luminosity; somewhat less than proportional to square root of luminosity. Nevertheless, this may turn out to be at least as important. How important may depend on the development in a completely different field, namely that of ultrahigh vacuum, as it is just signal-to-background considerations that have led us to aim for 10^{-11} torr in the interaction regions. This is, in principle, possible by cryopumping with liquid helium. So far, however, we have not yet been able to overcome all the difficulties encountered making a good cryopumping system.

With the intensity improvement possibilities mentioned the probability of having difficulties with various space charge phenomena has increased. We believe that the lowest space charge limit in the ISR will be the transverse coherent limit, estimated to be at 130 A. We shall, of course, be very happy when we reach such high stacked currents. There are, however, methods proposed for changing the image coefficients significantly with modifications of the vacuum chamber. It is, therefore, hoped that this phenomenon will not cause a serious intensity limitation.

We have always planned to suppress transverse resistive instabilities by the introduction of sextupole fields. This method should work up to the intensities mentioned as possible with the improvement programme.

There is, of course, the possibility of as yet undiscovered phenomena that may be more restrictive. This, however, is a problem that one always has to live with when one makes a considerable step forward in accelerator construction.

And then there are the practical problems that may be difficult, if not impossible, to overcome. Some of the beam manipulation schemes required to reach the highest intensities talked about, would necessitate a considerable technological advancement in the years

to come. For the time being, we restrict ourselves to carefully avoiding, whenever possible, building into the machine features that would make it unnecessarily difficult to provide for desirable modifications later.

As an example of practical difficulties that we have to solve and that we have not met in the same way in accelerator construction so far, I would like to mention the beam dumping, in particular the precautions necessary in cases of accidental beam dumping⁵⁾. As mentioned, the present design aim, without the improvement possibilities, is to reach 20 A circulating proton beams at 28 GeV. This means that the stored energy in each beam is 1.7 MJ, and we can certainly not let this hit the vacuum chamber or any other equipment if there is a power failure or other faults with similar results. One reason for the severity of the problem is, that the accidental dumping will occur in such a short time that we must disregard the heat conduction. For a beam of 4×10^{14} protons, with a cross-section of 7 cm x 1 cm, incident perpendicular on a block of metal we find, for instance, the maximum temperature increases and corresponding thermal stresses given in Table II. The same Table also gives a few relevant material properties.

The Table in itself illustrates the problem. For instance, there is no possibility of letting the beam hit the leading edge of a metal block slowly (i.e. in this context slowly compared with revolution time) as the local temperature will then go even higher than presented in the Table. One must have a dump area about as large as the beam cross-section or larger. Our present plan is to deal with the problem in the following way. A fast-rising closed orbit bump will be created by two pulsed magnets $l/2 \lambda_\beta$ apart. The magnets must be excited automatically when a fault requiring emergency dumping develops, for instance a power failure. A dump block will be placed halfway between the two pulsed magnets, at the edge of the good aperture. The block will be made of titanium, a choice that is obvious from Table II, and have a length of about 2 m (corresponding to about 7 mean free paths). The density of energy deposition is

TABLE II

Maximum temperatures and stresses when absorbing
a $7 \times 1 \text{ cm}^2$ stacked beam of 4×10^{14} protons

Material	ΔT	$\sigma_{th} \approx \alpha E \Delta T^{*})$	Melting point	Approximate tensile strength $\sigma_{max}^{*})$ of strongest alloy
Al	190°C	35 kg/mm ²	660°C	40 kg/mm ²
Ti	350	33	1660	125
Fe	375	90	1500	90
Cu	450	100	1080	50
W	1240	21	3380	110

*.) E and σ_{max} taken at room temperature

equal to the case considered in Table II when the increase of the amplitude of the closed orbit bump per revolution is about equal to the width of the stacked beam and therefore this method should be adequate up to the design current of 20 A.

For higher circulating currents different solutions must be found. This, however, we consider as a problem for the future. In such circumstances we intend to kick the stacked beam out of the machine with a large aperture ejection system consisting of a fast kicker and septum magnet.

3. Progress on the various parts

The progress of the project has gone roughly according to plan. The magnet cores have been ordered and the contract for the coils will be placed by the end of September. The specifications for most of the other big items like beam transfer magnets, main power supply, vacuum pumps and the stainless steel tube for the vacuum chamber etc. have either gone to industry or are in the final stages of preparation. All this is, of course, the result of extensive laboratory and model work over years.

I cannot go into more details on the various parts of the project, but reference can be made to many papers in the Proceedings from earlier International Accelerator Conferences describing the ideas behind the design of most parts. The design may have changed somewhat in the details, but little in the basic approaches to the various problems.

I shall, however, single out one part of the problem, namely the beam transfer system, as it so happens that very little attention has been paid to this important part at earlier conferences. Of course, I cannot go into detail, but a short description may help in appreciating the problems involved and our approach to them.

a) Beam transfer

The problems of transferring a beam from one ring to another one, or rather two other ones, at 25 - 28 GeV are quite different from and considerably more difficult than those encountered at injection into normal accelerators.

The lay-out of the beam transfer system for the ISR is shown in Fig. 2. The CERN site is not very flat, and to avoid unnecessary excavations the ISR will be about 12 m higher than the CPS. As a consequence we have had to give parts of the beam transfer tunnels slopes of about 10%. The strict dispersion requirements, both vertically and horizontally, will be met by the appropriate choice of distance between bending magnets and of the focusing properties of the channels.

Unfortunately, all components in such a system become very interrelated, leading to inconveniently much work to analyse the effects of proposals of seemingly small modifications, and sometimes with surprising results far away from the point of modification.

The strong vertical bending in the beams has led us to choose a rather unorthodox septum arrangement for the inflection. The beam to be inflected approaches the ISR ring at a vertical slope of 7.6%. It passes just in front of the yoke of an ISR magnet and just below the coil of that magnet. It is then made parallel to the vacuum chamber centre line both vertically and horizontally by two so-called steel septum magnets inclined at angles of 15° and 19° to the vertical. A steel septum magnet can best be described as a picture-frame magnet with a large slot in the pole (see Fig. 3).

Figure 4 shows a photo of one of our models. Some difficulties with stray-fields occurred, mainly related to the fact that the slot is unsymmetric both in angle and in position with respect to the coils on the original model. To remedy this we shall increase the gap width, to reduce the asymmetry, and put a simple correcting coil around one of the return yokes. A final model is under construction.

b) The Buildings

The civil engineering part of the project is the most advanced one, as it must be able to house the components that have now been ordered, when they start coming in during the latter half of 1968. Figure 5 shows a photograph of the present state on the French part of the CERN site. About 60% of the excavation work is over and concrete work has started both on the Ring Tunnel and on the West Hall. Nevertheless, certain changes have taken place in our lay-out in fact as late as a month ago. Few people would notice the changes, perhaps, by comparing present plans with those presented two years ago. They may nevertheless be of considerable importance for the ease of doing experimentation in the future, and have in fact been initiated by discussions among prospective users over the last few years. The main change has been to suppress the experimental hall around the interaction region 5 and replace it by a hall of a different shape around interaction region 1 (see Fig. 1). The original I_5 was very similar in shape to I_4 . The new I_1 puts more emphasis on experimentation with particles coming out at large angles. It has therefore much larger dimensions at right angles to the beams. The latest change has been to enlarge the hall further and to make the 5 m deep pit also larger to accomodate not only a big experimental set-up, like for instance the so-called Ω -project, but also to assemble such equipment on the same level, but away from the beams.

4. Comments on time schedule and cost

Since the project was authorised, we have aimed at starting the commissioning by mid-1971. We have so far no signs of a set-back in the project that would make this date invalid. With about 30% of the contracts being placed we feel rather confident that we shall also be able to stay within the cost estimate of 332 MSF (at 1965 prices). We shall, however, know much more by the time of next International Accelerator Conference, and I hope that by then I am able to show the same optimism.

REFERENCES

1. E.D. Courant, E. Keil, A.M. Sessler: "Improvement Possibilities in the Performance of the CERN Intersecting Storage Rings", (paper presented to the VIth International Conference on High-Energy Accelerators).
2. A. Sørenssen: CERN Report MPS/Int. MU/EP 66-2.
3. E. Keil: CERN Report ISR-TH/67-10.
4. W. Schnell: "Stacking in Proton Storage Rings with Missing Buckets", (paper presented to the VIth International Conference on High-Energy Accelerators).
5. W.C. Middelkoop and B. de Raad: CERN Report ISR-BT/67-49.

FIGURE CAPTIONS

Fig. 1 : Lay-out of the ISR Project.

Fig. 2 : Lay-out of the beam transfer system for the ISR.

Fig. 3 : View and cross-section of steel septum magnets.

Fig. 4 : Model of a steel septum magnet.

Fig. 5 : Present state of the ISR site.

1. The first part of the document discusses the importance of maintaining accurate records of all transactions and activities. It emphasizes that this is essential for ensuring transparency and accountability in the organization's operations.

2. The second part of the document outlines the various methods and tools used to collect and analyze data. It highlights the need for consistent data collection procedures and the use of advanced analytical techniques to derive meaningful insights from the data.

3. The third part of the document focuses on the role of technology in data management and analysis. It discusses how modern software solutions can streamline data collection, storage, and analysis, thereby improving efficiency and accuracy.

4. The fourth part of the document addresses the challenges associated with data management, such as data quality, security, and privacy. It provides strategies to mitigate these risks and ensure that the data remains reliable and secure.

5. The fifth part of the document concludes by summarizing the key findings and recommendations. It stresses the importance of ongoing monitoring and evaluation to ensure that the data management processes remain effective and up-to-date.

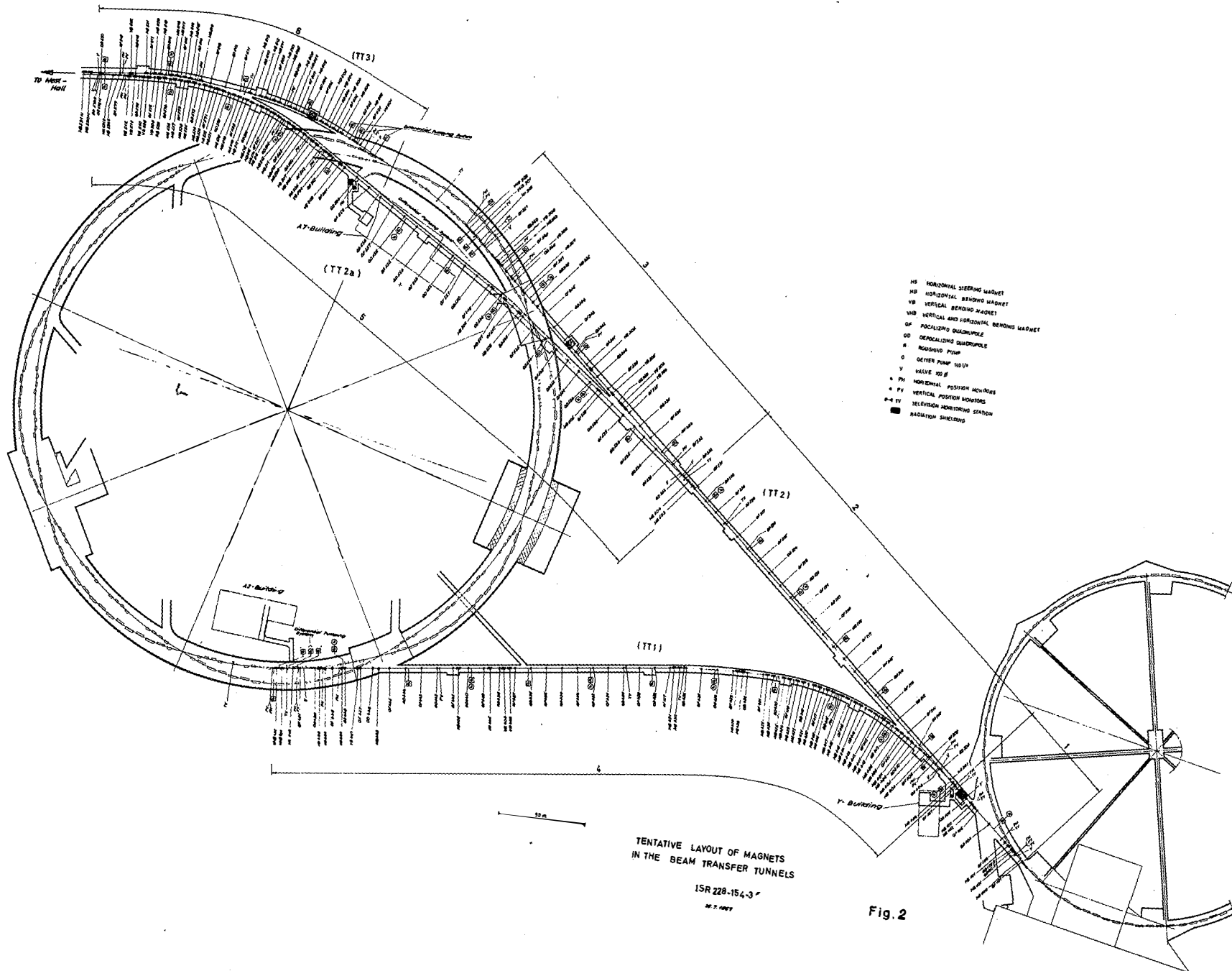

- H1 HORIZONTAL STEERING MAGNET
- H2 HORIZONTAL BENDING MAGNET
- V1 VERTICAL BENDING MAGNET
- V2 VERTICAL BENDING MAGNET
- VH VERTICAL AND HORIZONTAL BENDING MAGNET
- QF FOCALIZING QUADRUPOLE
- QD DEFOCALIZING QUADRUPOLE
- R ROUGHING PUMP
- C GELTER PUMP 100 L/S
- V VALVE 30 Ø
- PH HORIZONTAL POSITION MONITOR
- PV VERTICAL POSITION MONITOR
- R-4 TV TELEVISION MONITORING STATION
- RADIATION SHIELDING

TENTATIVE LAYOUT OF MAGNETS
 IN THE BEAM TRANSFER TUNNELS
 ISR 228-154-3
 NO. 7 1987

Fig. 2

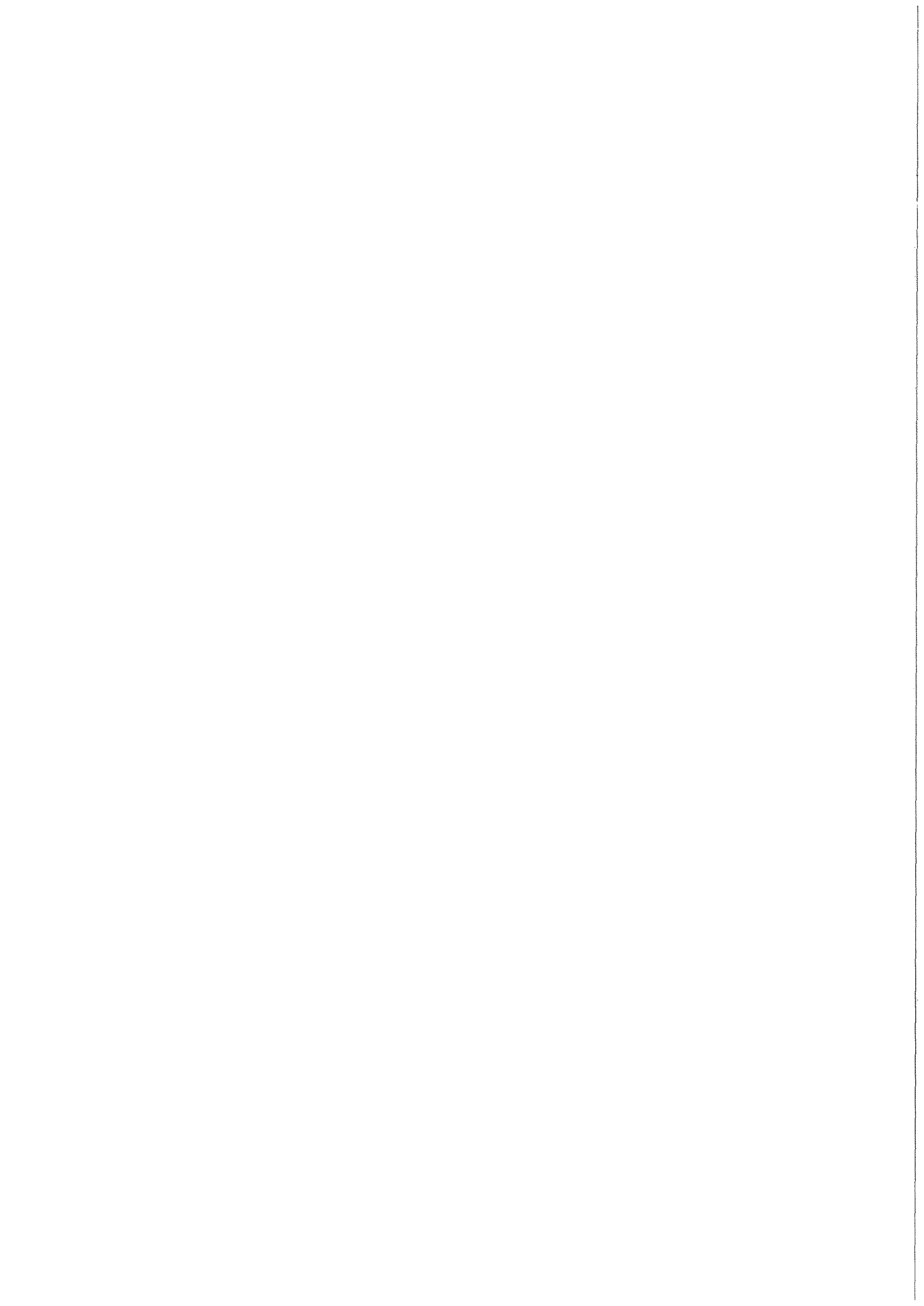

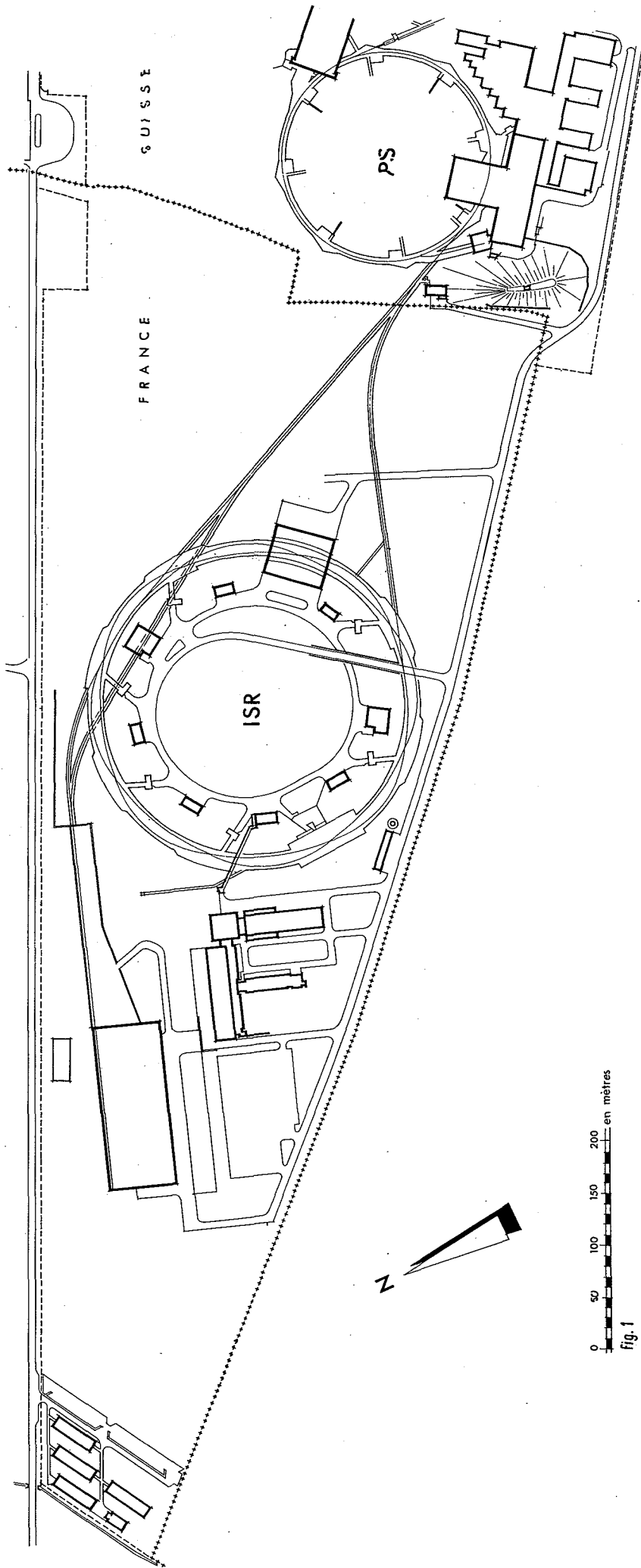

0 50 100 150 200 en mètres
fig. 1

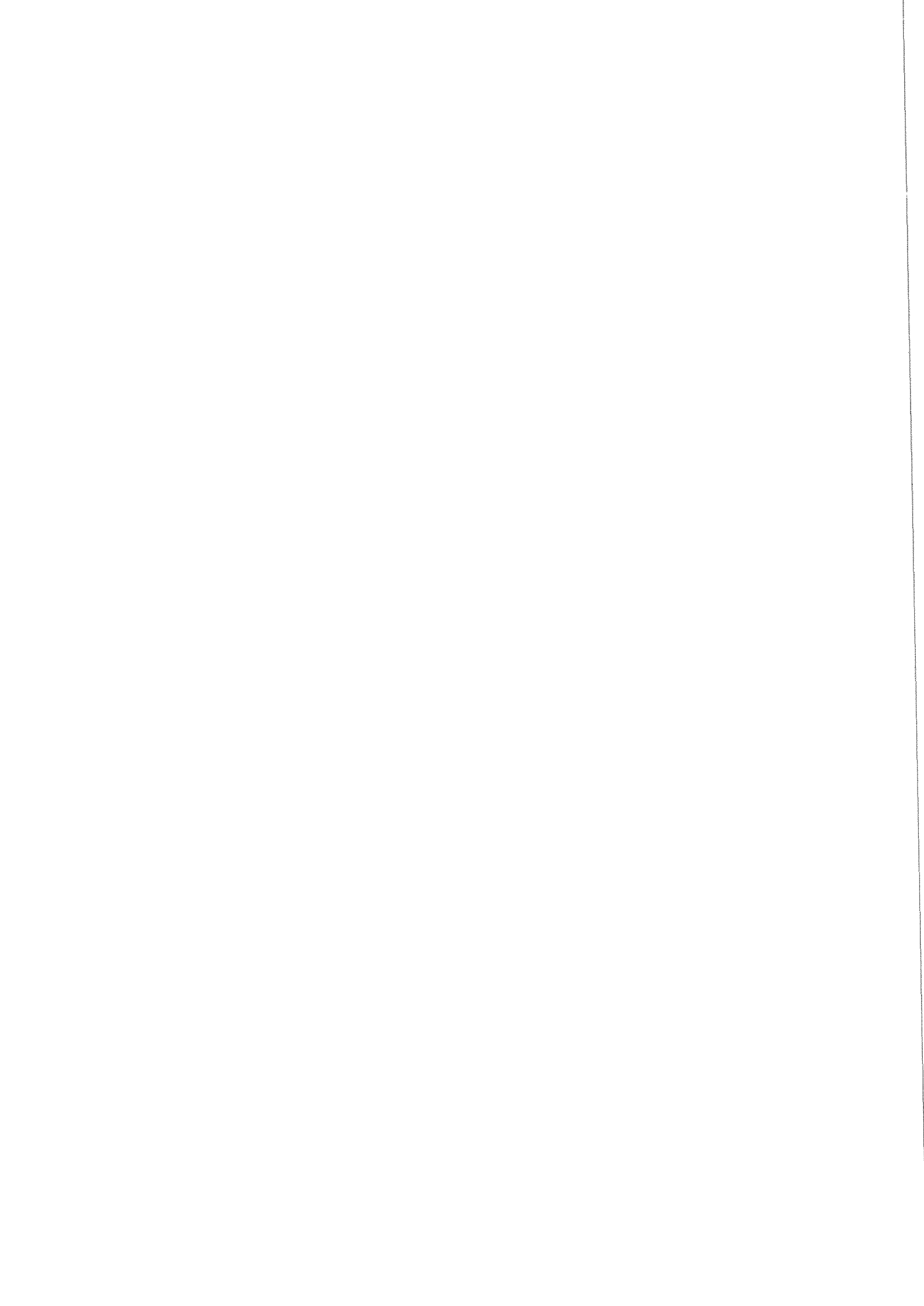

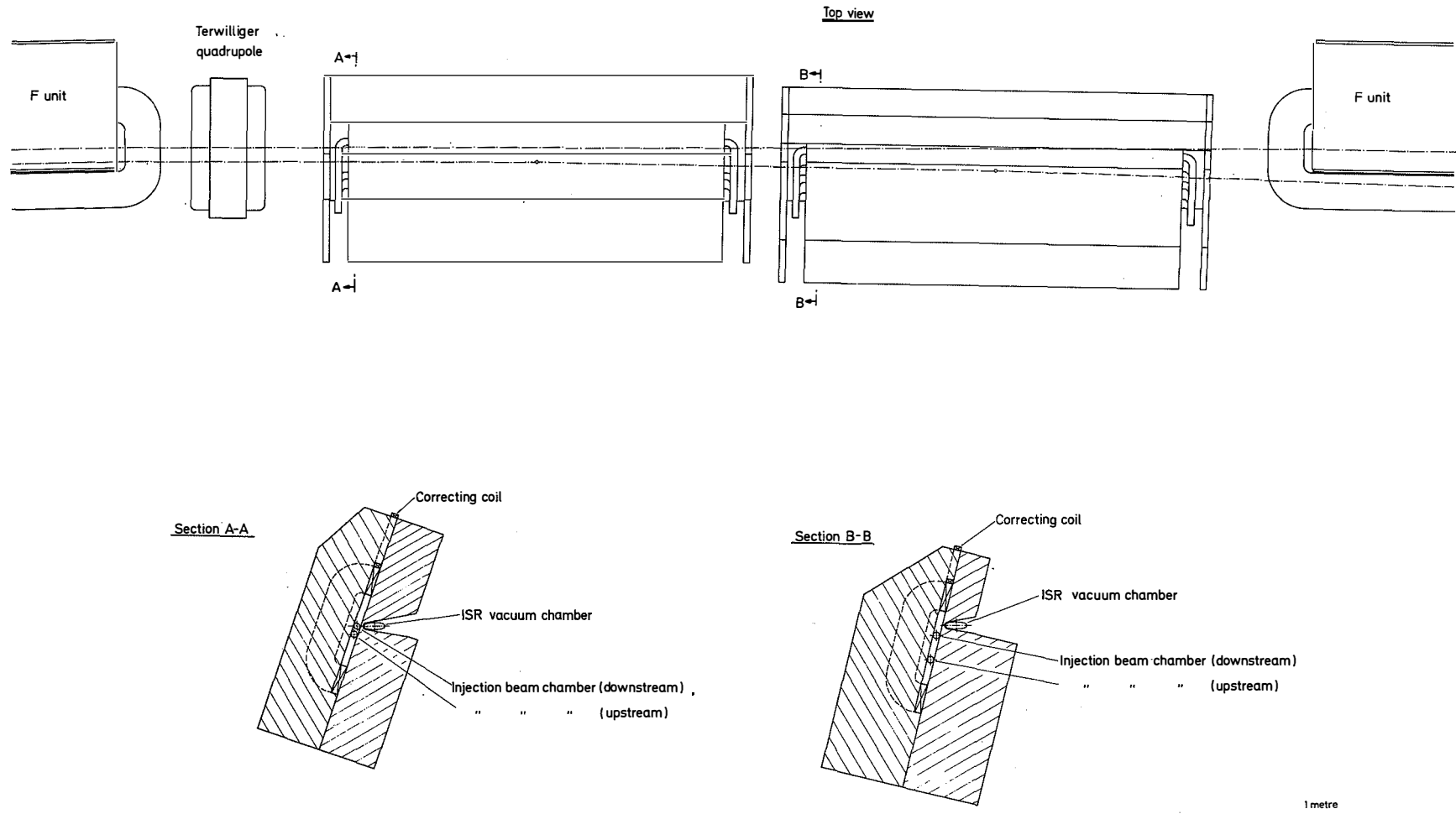

Fig. 3 View and cross-section of steel septum magnets

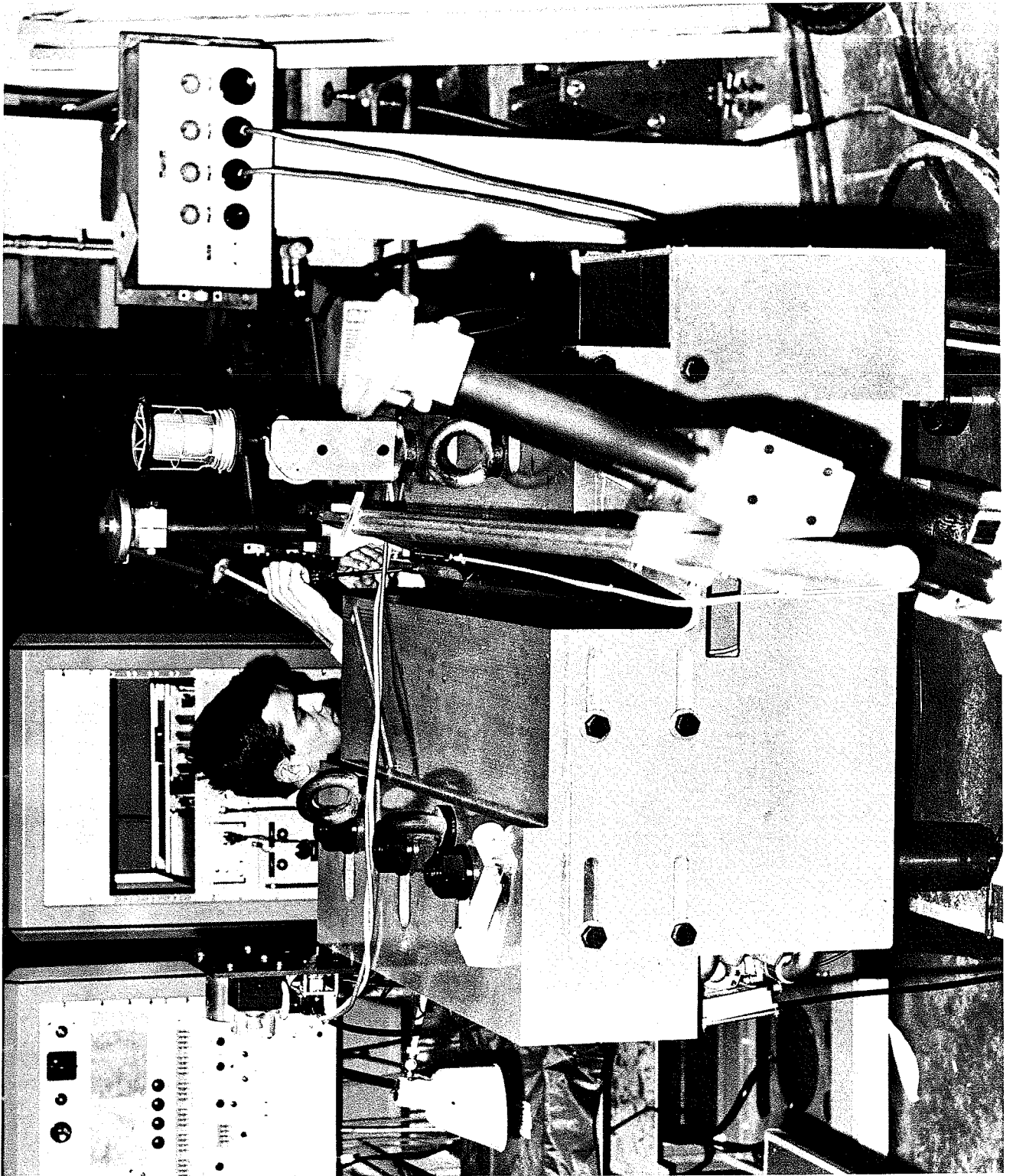

Fig. 4



Fig. 5

1. The first part of the document discusses the importance of maintaining accurate records of all transactions. It emphasizes that proper record-keeping is essential for the integrity of the financial system and for the ability to detect and prevent fraud. The text notes that without reliable records, it would be difficult to track the flow of funds and identify any irregularities.

2. The second part of the document focuses on the role of internal controls in ensuring the accuracy and reliability of financial information. It describes how internal controls are designed to prevent errors and detect any unauthorized transactions. The text highlights that a strong internal control system is a key component of an organization's risk management strategy.

3. The third part of the document discusses the importance of transparency and accountability in financial reporting. It notes that stakeholders, including investors and regulators, rely on accurate and timely financial information to make informed decisions. The text emphasizes that organizations should strive for transparency in their reporting and be held accountable for the accuracy of the information they provide.

4. The fourth part of the document addresses the challenges of financial reporting in a complex and rapidly changing environment. It notes that organizations face various risks, including changes in market conditions, technological advancements, and regulatory requirements. The text suggests that organizations should adopt a proactive approach to risk management and ensure that their financial reporting processes are robust and resilient.

5. The fifth part of the document discusses the importance of ongoing monitoring and evaluation of financial reporting processes. It notes that organizations should regularly review their internal controls and reporting procedures to ensure they remain effective and up-to-date. The text emphasizes that a continuous improvement process is essential for maintaining the highest standards of financial reporting.

6. The sixth part of the document discusses the importance of communication and collaboration in financial reporting. It notes that effective communication is essential for ensuring that all stakeholders are aware of the organization's financial performance and the risks it faces. The text emphasizes that organizations should foster a culture of transparency and open communication, where employees are encouraged to report any potential issues or concerns.

7. The seventh part of the document discusses the importance of training and education in financial reporting. It notes that employees should receive regular training and education to ensure they are up-to-date on the latest accounting standards and reporting requirements. The text emphasizes that a well-trained workforce is essential for the accuracy and reliability of financial reporting.

8. The eighth part of the document discusses the importance of external audits in financial reporting. It notes that external audits provide an independent and objective assessment of an organization's financial statements. The text emphasizes that organizations should engage with reputable external auditors and ensure that they are fully transparent and cooperative in the audit process.

9. The ninth part of the document discusses the importance of staying up-to-date on regulatory changes in financial reporting. It notes that regulatory requirements are constantly evolving, and organizations must stay informed of the latest changes to ensure compliance. The text emphasizes that organizations should have a process in place to monitor and respond to regulatory updates.

10. The tenth part of the document discusses the importance of maintaining a strong ethical culture in financial reporting. It notes that a strong ethical culture is essential for ensuring the integrity and reliability of financial information. The text emphasizes that organizations should promote a culture of honesty, integrity, and ethical behavior, where employees are encouraged to do the right thing, even when it is difficult.