

# LHC ABORT GAP MONITOR ELECTRONICS UPGRADE

D. Belohrad, S. Mazzone, M. Martin Nieto, P. Pacner\*, S. B. Pedersen, CERN, Geneva, Switzerland

## Abstract

The LHC Abort Gap Monitor (AGM) is part of the LHC machine protection system (MPS) and is designed to measure the particle population in a  $3\ \mu\text{s}$  wide region known as the "abort gap". This region needs to be kept empty to ensure safe beam dumps. The AGM captures the synchrotron light generated in the visible part of the spectrum and converts it into an electric signal. This signal is then processed by an acquisition system and can trigger the 'abort gap cleaning' process. The current AGM, which has been in operation since 2010, uses an analogue integrator ASIC and a 40 MHz analogue-to-digital (ADC) converter to provide the particle population information. However, this solution is now considered obsolete and is being replaced by a digital signal processing approach. Working directly in the digital domain not only offers more scalability but also better determinism and reliability. This work presents the new technical solution for the acquisition chain, compares the characteristics of both implementations, and showcases recent measurements conducted on the LHC ion beams.

## INTRODUCTION

The LHC ring stores up to 350 MJ of beam energy, when operating at the flat top energy, spread across 2808 bunches with an average beam transverse size under 1 mm. This high energy density can melt metallic surfaces and quench superconducting magnets, posing a risk to the machine [1]. To safely extract the beam from the circulating beam lines, a series of kicker magnets belonging to the beam dump system is used. Kicker magnets need  $3\ \mu\text{s}$  to ramp up their magnetic field [2]. This defines the duration of an Abort Gap (AG) in the bunch train. Due to system imperfections, a residual amount of particles populates this gap. The typical AG population levels are two to three orders of magnitude lower in comparison to a single pilot LHC bunch. When the beam dump is initiated, the particles in the AG do not receive full extraction kicks, leading to losses along the dump line that could result in damage or magnet quenching. The purpose of the AGM is a continuous monitoring of the AG population in order to trigger the abort gap cleaning when necessary [3]. This paper discusses the upgrade of the operational AGM installed in the LHC since 2010, detailing the system architecture and analogue electronics chain, and provides a first performance comparison of both systems.

## SYSTEM ARCHITECTURE

The system architecture is shown in Fig. 1. It depicts the layout of the LHC, with beam 1 represented in blue and beam 2 in red. The LHC AGM consists of three main parts:

1. **optical front-end (OF)**, which includes a pre-amplifier, located in the LHC tunnel,
2. **data acquisition system (DAQ)** deployed on an FPGA platform located outside the radiation area,
3. **control software (SW)** that retrieves, interprets, and publishes the measured data.

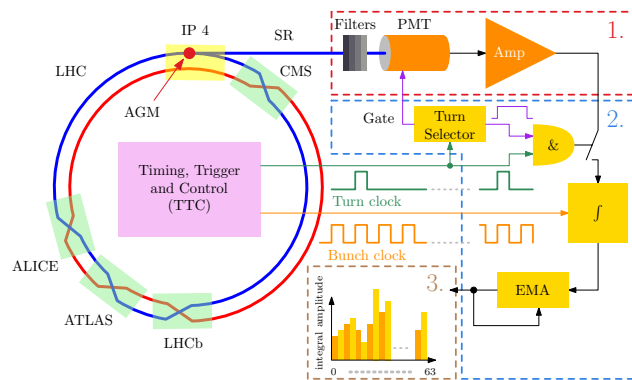

Figure 1: Overview of an abort gap monitor system.

The AGM is installed at LHC IP4 as one of the beam diagnostics based on synchrotron radiation (SR) detection. The LHC timing distribution (TTC) broadcasts along the LHC turn and bunch marks, together with other information, as e.g., actual beam energy [4]. The bunch and turn marks identify the start of each individual bunch, and the position of the first bunch in a turn. The AGM uses this information to re-synchronize its acquisition window to the AG.

## Working Principle

An in-vacuum mirror intercepts SR emitted by particles passing through magnets located approximately 27 m upstream. It then directs the radiation to a dedicated optical line installed beneath the beam pipe.

The AGM collects part of the extracted SR via Multi-channel plate photo-multiplier (MCP-PMT) converting it into an electric signal. Neutral density filters in the optical front-end (OF) allow changing the light intensity, thus optimize the system dynamic range. Subsequently, the electric signal is amplified and transmitted over a 100 m-long cable to DAQ. The DAQ integrates the incoming signal in 100 ns intervals within a  $6.4\ \mu\text{s}$ -long acquisition window. Each of the 64 100 ns integrals is independently averaged in an Exponential Moving Averager (EMA). The averaged result is published to the software with a repetition rate of 10 Hz, which is sufficient to react to even the fastest changes in AG population. [5].

The measurement period depends on the specific MCP-PMT (HAMAMATSU R5916U-50) that features a maximum duty cycle of 1%. With a gate pulse duration of  $3\ \mu\text{s}$  and one LHC revolution period of  $89\ \mu\text{s}$ , the measurements are

\* petr.pacner@cern.ch

taken every 4<sup>th</sup> clock cycle (356  $\mu$ s). This corresponds to a duty cycle of 0.84 %.

### Operational System, Used Since 2010

The currently used system is shown in Fig. 2. The optical path, including filters and MCP-PMT, is common to both the operational version of the system, and the proposed upgrade. The operational setup utilizes a digital acquisition board

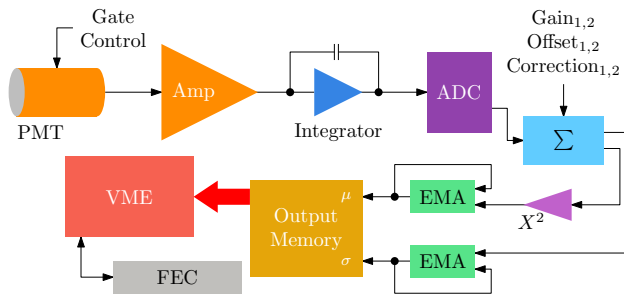

Figure 2: Operational AGM system overview.

(DAB64x) incorporating an Altera Stratix EP1S40 FPGA for data processing. The DAB64x hosts two Individual Bunch Measurement Systems (IBMS) [6], integrating the analog input signal via the LHCb2002 ASIC [7]. The analog signal generated by the MCP-PMT is amplified prior to integration to enhance the measurement's Signal-to-Noise Ratio (SNR). The amplifier (HAMAMATSU C5594 [8]) has a fixed voltage gain of 36 dBV and the bandwidth of 1.5 GHz with the low cutoff frequency at 50 kHz. The amplified signal is fed to the LHCb2002 in the IBMS integrating in 25 ns intervals, producing a stream of analog 'DC-like' values. These are subsequently sampled by a 40 MSPS 14-bit ADC, resulting in a digital data stream, where each value corresponds to an integral of an individual LHC 25 ns bucket. The DAQ gateway sums four consecutive samples to compute the charge present on a 100 ns interval. This process generates 64 values per single turn acquisition. For each individual value, a standard deviation and mean value is calculated, and separately filtered by EMA. All collected data are stored in a RAM block shared to a front-end computer (FEC) via VME64 bridge. A dedicated front-end server publishes the data stream through FESA [9].

### Reasons for Upgrade

The operational AGM primarily relies on outdated technology, such as the analogue integrators used in the IBMS, which are no longer manufactured. Furthermore, each integrator is unique, with varying gain, switching characteristics, and offsets. The gateway must correct these variations. In addition, the amplifier bandwidth (50 kHz-1,5 GHz) requires a correction for the missing DC component. The amplifier gain is fixed, so the signal amplitude cannot be adapted to optimally re-use the available ADC dynamic range. The system also relies on an outdated FPGA platform, and the development SW is no more compatible with the latest operating systems.

## SYSTEM UPGRADE

To address the long-term maintenance concerns, the original system described above has to be refurbished. While the optics of the new system was copied from the operational one, the DAQ and the front-end amplifier were replaced by a modern solution. A new DC-coupled variable gain amplifier was designed. It was decided to change from analog to digital integration of the MCP-PMT signal. The signal is digitized by a DAQ based on a 4-channel 500 MSPS 14-bit FMC-form factor sampler. The FMC ADC module is installed into an in-house built FPGA carrier (VFC-HD), featuring 2x8GBits DDR3 memories and a large Arria V FPGA. Such a solution eliminates completely the need for the analogue integrators, as all the signal processing can be implemented in the gateway. In early 2023, the new AGM system was installed alongside the legacy system to compare both systems' performance.

### New DC-Coupled Amplifier

Figure 3 depicts the block diagram of the new amplifier. The amplifier was designed to match the AGM MCP-PMT and to be highly configurable. A universal asynchronous receiver-transmitter (UART) interface allows for setting a trans-impedance gain. The gain is adjustable in a range of 5.8 mV/ $\mu$ A to 1.1 V/ $\mu$ A. This corresponds to a voltage gain of 41 dB to 87 dB in a 50 $\Omega$  system. A programmable DC-offset compensation is implemented. It can be used - together with variable gain - to optimize the signal's amplitude for the ADC. The amplifier design incorporates an alarm. This alarm interlocks the MCP-PMT gate when the incident light produces a current nearing the MCP-PMT's maximum allowable average current. The alarm threshold setting is stored through the UART into the amplifier's non-volatile memory, so that the MCP-PMT is protected also after a power reset.

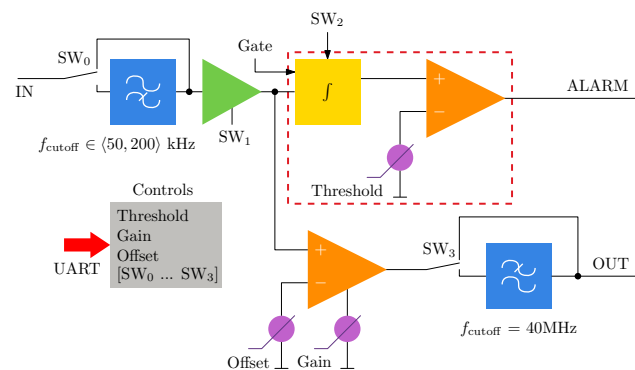

Figure 3: New AGM custom amplifier.

### Acquisition System

The new DAQ (Fig. 4) receives asynchronous data samples as a stream of four frames every 8 ns, each corresponding to one channel. Each frame contains 4x16-bit words, storing left-aligned 14-bit ADC samples. To compute integrals over 4x 25 ns bunch slots, the system employs data

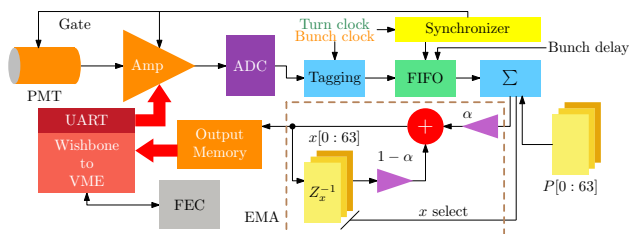

Figure 4: Acquisition system schematics.

tagging. The tagger resamples the LHC timing, and generates timing masks that provide each individual ADC frame with bunch and turn start markers. Tags are inserted into the 2 unused least significant bits (LSBs) of each word to indicate the start of the the bunch or turn.

The tagged samples are stored in a FIFO (First In, First Out), and then integrated. The integrator is triggered by the first bunch tag appearing within the acquisition window. In parallel, the system reads a stream of 64 values of a stored 'offset' from a pedestal memory ( $P[63:0]$ ). The offset is subtracted from the integrated data stream on the fly. Such pedestal subtraction is needed to remove systematic effects, e.g. related to the MCP-PMT gate opening. The output values are filtered by EMA, the results are stored in RAM, and then read out through the VME64x bus [10].

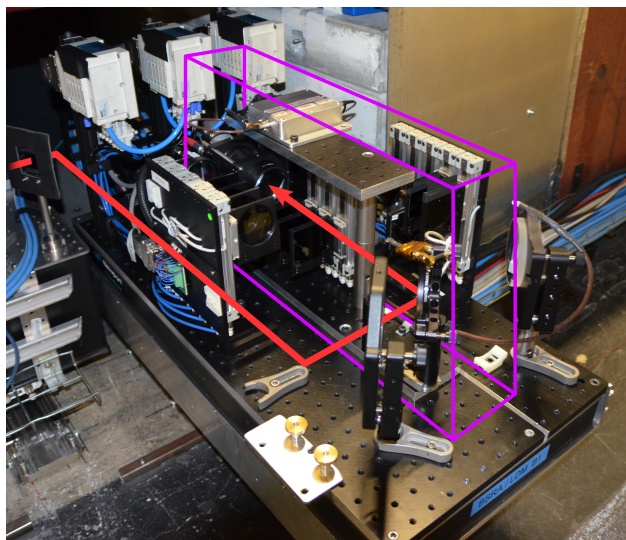

Figure 5: New AGM installed in the LHC IP4, next to BSRT.

### Installation in the LHC

The new installation, shown *in retracted position*, is highlighted by a violet frame in Fig. 5. The operational AGM (on the right) and the longitudinal density monitor (LDM, on the left) are also partially visible in the same figure. All these instruments are part of the LHC beam synchrotron light telescope (BSRT) and use part of the synchrotron radiation extracted by the in-vacuum extraction system sitting above the BSRT. The red arrow indicates the direction of the light entering the optical table. The light is unequally split using multiple reflective foils into their respective destinations. The new AGM receives only 10% of the radiation

sent to the operational AGM. Both AGMs are equipped with LEDs installed on top of their reflective foils for functional and calibration tests. The new AGM amplifier is mounted on the top of the optical front-end to ease the interventions.

## FIRST MEASUREMENTS

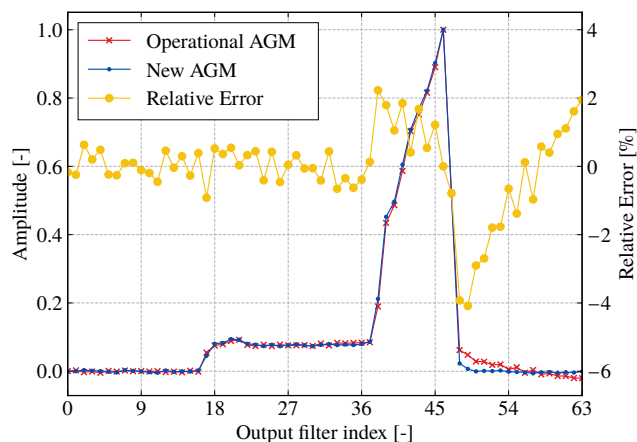

Figure 6: Example of a comparison between old and new AGM measurements, binned in 100 ns slots (*output filter indices*). The MCP-PMT gate is *open* between index 17 and 47.

A first set of measurements with the new AGM system were taken during the 2023 Ion Run, and the comparison to the operational AGM is shown in Fig. 6. During the period in which the MCP-PMT gate is open (between index 17 and 47 in the plot) the agreement between old and new system is within  $\pm 2\%$ . When the MCP-PMT gate closes at index 47 the operational system exhibits a slow (several 100 ns slots) decay to non-physical negative values. This effect was found to be systematic, and traced back to non-optimal analog signal processing and integration. The new system eliminates this effect.

## SUMMARY

The current LHC AGM system requires refurbishing to assure long-term maintainability of the DAQ. This paper outlines the new DAQ design, which is a fully digital solution incorporating digital integration. An initial prototype was installed to monitor the LHC on beam 1, working in tandem with the operational AGM.

In 2023, a series of measurements with ions demonstrated exceptional performance, even with significantly less intercepted light, and showed strong alignment with the legacy system.

The unit is now gathering data with protons, which will facilitate further analysis regarding its accuracy, reliability, and stability. Once the system is fully validated, both LHC AGMs will transition to the new version.

## REFERENCES

- [1] O. S. Brüning *et al.*, "LHC design report Volume I: The LHC Main Ring", CERN, Geneva, Switzerland, Rep. CERN-2004-003-V-1, Jun 2004.
- [2] R. Filippini, E. Carlier, L. Ducimetière, B. Goddard, and J. A. Uythoven, "Reliability Analysis of the LHC Beam Dumping System", in *Proc. PAC'05*, Knoxville, TN, USA, May 2005, paper TPAP010, pp. 1201–1203.
- [3] M. Meddahi *et al.*, "LHC Abort Gap Monitoring and Cleaning", in *Proc. IPAC'10*, Kyoto, Japan, May 2010, paper MOPEC009, pp. 474–476.
- [4] B. Taylor, "TTC distribution for LHC detectors", *IEEE Trans. Nucl. Sci.*, vol. 45, no. 3, pp. 821–828, 1998.  
doi:10.1109/23.682644
- [5] C. Fischer, "High Sensitivity Measurement of the Beam Longitudinal Distribution of the LHC Beams" CERN, Geneva, Switzerland, Rep. LHC-B-ES-0005 v.2.0, Jan 2003.
- [6] A. Guerrero, H. Jakob, J. J. Savioz, and R. Jones Geneva, "The SPS Individual Bunch Measurement System", in *Proc. DIPAC'01*, Grenoble, France, May 2001, paper PM12, pp. 192–194.
- [7] G. Böhner *et al.*, "Very front-end electronics for the LHCb preshower", CERN, Geneva, Switzerland, Rep. CERN-LHCb-2000-047, Oct 2000.
- [8] S. Bart Pedersen *et al.*, "First Operation of the Abort Gap Monitors for LHC" CERN, Geneva, Switzerland, Rep. CERN-ATS-2010-111, May 2010.
- [9] L. Fernandez *et al.*, "Front-End Software Architecture", in *Proc. ICALEPCS'07*, Oak Ridge, TN, USA, Oct. 2007, paper WOPA04, pp. 310–312.
- [10] P. Pacner, "LHC Abort Gap Monitor Acquisition System", Master's thesis, Brno University of Technology, 2022.