

BB

GANIL

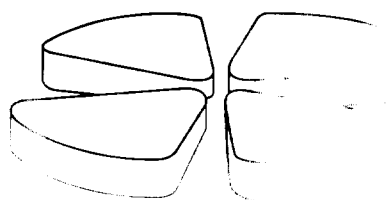

*to be presented at the 14th International Conference on Cyclotrons
and their Applications, Cap Town, 8-13th October 1995*

UPGRADING THE GANIL FACILITIES FOR HIGH-INTENSITY HEAVY ION BEAMS (T.H.I. PROJECT)

E. BARON and the GANIL Staff
GANIL - B.P. 5027 - F-14021 Caen Cedex France

SCAN-9510261



CERN LIBRARIES, GENEVA

SW 9544

GANIL A 95 03

UPGRADING THE GANIL FACILITIES FOR HIGH-INTENSITY HEAVY ION BEAMS (T.H.I. PROJECT)

E.BARON and the GANIL Staff
GANIL - B.P. 5027 - F-14021 Caen Cedex France

Abstract

A new project, called THI, is underway at GANIL for taking advantage of the high intensities extracted from the 14 GHz ion source. The goal is to boost the present beam intensities by a factor of the order of 15 for light ion species up to Ar while coping with beam powers of several kW. The paper describes the status of the numerous components of this upgrading : non-interceptive beam diagnostics, beam loss detection, supervision of electric and magnetic supplies, thermal shielding, solutions for radiation and safety problems, movable stripper, etc. The status of a rebuncher to be placed between the two separated sector cyclotrons in order to ameliorate the extraction efficiency of the last cyclotron is also presented.

1. INTRODUCTION

The present and future methods of producing radioactive ion beams at GANIL may be described as follows :

- projectile fragmentation method : this is achieved with a device called SISSI[1]. The energetic beam is very sharply focused through a superconducting solenoid onto a thick target and the fragments are collected with a large angular acceptance thanks to a second superconducting lens. Since SISSI is located close to the output of the second Separated Sector Cyclotron (SSC2), these fragments may be directed to any experimental cave but, of course, there is no way to vary their energy, other than slowing them down by a thick target.
- Isol technique : the radioactive species are produced by stopping the beam completely in a thick target, with a subsequent ionization in an ECR source and acceleration through an additional, especially dedicated cyclotron : this is the SPIRAL project[2] which is under construction in our laboratory.

Due to the low production cross-sections, an important parameter in the statistics of the experiments is the incoming beam intensity. In 1992, we commissioned a new high intensity axial injection system [3] whose characteristics are :

- a 14 GHz ECR source installed on a 100 kV injection stage
- a beam transport system from this platform to one of the injectors, allowing for the 6-dimensional matching of the beam, taking into account space charge forces and the different couplings between phase planes
- a new design of the injector central region, involving a spiral-type inflector.

The general layout of the present and future accelerators is shown on figure 1.

The intensities that can be extracted from the injector are presently well above what can be accepted by the two SSCs in terms of beam power and radiation hazards ; the solid stripper lifetime is also a problem. Therefore, a series of actions, called the THI (Transport des

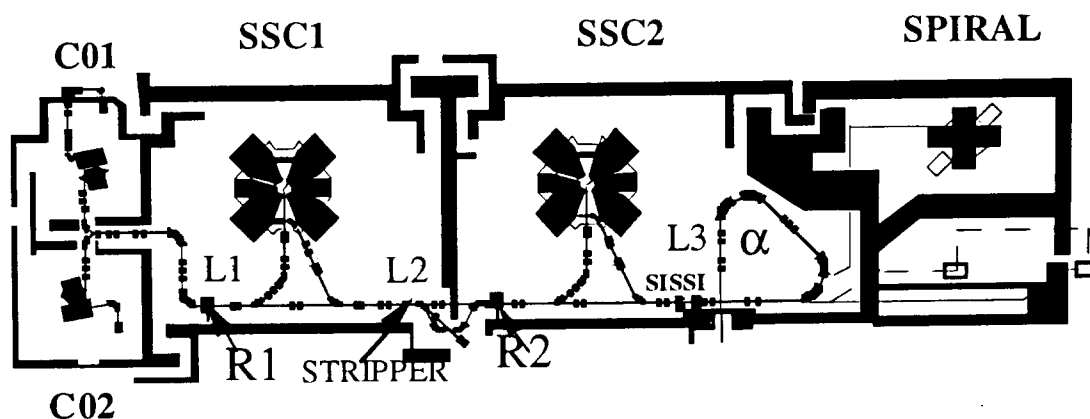

Fig.1. GANIL : general layout . C01, C02 : injector cyclotrons ; SSC1, SSC2 : separated sector cyclotrons ; R1, R2 : rebunchers (the experimental areas are omitted)

Hautes Intensités) project, had to be undertaken in order to adapt the existing facility to this new situation. In the following paragraphs, we indicate the aim for output intensities, the consequences in terms of thermal effects and radiation hazards, minimization of beam losses, stripper foil lifetime, and the cures to be brought. The status of all the projected actions is given.

2. EXPECTED BEAM INTENSITIES AND CONSEQUENCES

In this high intensity project, most of the problems arise from "light ion" beams, that is (by our standards) for ion species up to argon. Since GANIL is still in the process of requesting the possibility to use He, Li, Be and B projectiles from the national authorities, we will concentrate only on the atomic number interval from $Z=6$ to $Z=18$; similarly, only beams obtained from gases are mentioned because metallic ion are in general more difficult to obtain with comparable currents. Table 1 shows the present intensities which are limited to an SSC2 output power of 400 watts for safety reasons, along with the expected intensities and the corresponding power.

Projectile	Present intensity(pps) for 400 watts	Expected intensity (pps)	Beam power (kW)
^{12}C	2.2×10^{12}	2×10^{13}	3.7
^{16}O	1.6×10^{12}	2×10^{13}	4.9
^{20}Ne	1.3×10^{12}	2×10^{13}	6.1
^{36}Ar	7.3×10^{11}	1.1×10^{13}	6.0

Table 1. The beam power is given for 95 MeV/n beams.

As an example, table 2 presents the expected characteristics for an ^{36}Ar beam.

	i(pps)	Energy (MeV/n)	Beam power (W)	Transmission efficiency (%)
Injection line	4.3×10^{13}	0.024	6	85
CO injection	3.7×10^{13}	0.024	5	
CO extraction	2.4×10^{13}	0.98	135	65
L1 beam line		0.98	135	70
SSC1 injection	1.7×10^{13}	0.98	96	
" extraction	1.6×10^{13}	13.6	1,256	96
Stripper + L2	1.6×10^{13}	13.6	1,256	70 (stripper yield)
SSC2 injection	1.1×10^{13}	13.6	862	
" extraction	1.1×10^{13}	95	6,000	98

Table 2. Expected beam characteristics for ^{36}Ar .

The performances mentioned in the grey part of table 2 were already reached during a test, with the indicated intensities up to injection into SSC1, then through SSC1 with a chopped beam (10 % duty-cycle).

High intensity operation generates a series of problems :

- beam losses at SSC1 or SSC2 energies, whether transient or permanent, must be severely controlled for the damage they could cause to the machine components, specially uncooled or unshielded elements. A fast detection of these losses must be put in place, or some elements be specially thermally shielded where the losses are unavoidable, like the dipoles located downstream of the stripper or of SSSI.
- a fast detection system means a fast response by stopping the beam or reducing its intensity ; then, the faulty component must be quickly identified. For this reason, a number of current or voltage supplies are to be specially supervised.
- due to the small turn separation at extraction of SSC2, the septum will no longer be adapted to take an important part of the beam. A rebuncher located between SSC1 and SSC2 will ameliorate the extraction yield by minimizing the beam radial width.
- the damage caused to the thin tungsten wires of the beam profile monitors is presently reduced by chopping the beam ; the drawback is that the intensity optimization becomes inaccurate and, in addition, no control of the beam profile is possible at full intensity. Any further reduction required by an increase of the intensity would make the tuning worse . Therefore, these monitors must be partly replaced by non-interceptive elements.
- the carbon strippers have already a limited lifetime , which is obviously inversely proportional to the current density
- apart from the requirement for additional concrete shielding, concerning mostly the walls of the SSC2 cave, we must be prepared to safely remove and replace highly activated components in case their eventual failure would paralyze the accelerator.

The different components of this implementation and their status are presented in the next paragraphs.

3. BEAM TUNING AND CONTROL

Presently, tuning the accelerator consists in optimizing the beam without paying too much attention to the losses, provided the output is consistent with the experimental need. It is now necessary to turn to methods consisting in tuning the accelerators by minimizing these losses. In addition, there must be a fast reaction following a sudden beam loss. Finally, once the safety action is taken (usually a beam intensity reduction upstream of the sensor), it is necessary to rapidly locate the faulty element.

3.1 Sensors for tuning and controlling the beam

These sensors have to be non-interceptive and broad-band in order to accept both low and high intensities.

- For intensity measurements, in addition to the traditional Faraday cups, the input and output of each cyclotron is equipped with current transformers ; however, these elements which are operating at 530 Hz are not sufficiently accurate and stable to allow both precise intensity optimization and measurements of small beam losses : improvements are still necessary. In particular, we are thinking of developing a similar device using the natural microstructure of the beam.
- The beam profiles are presently measured by multiwire meshes with 20 μm diameter golden tungsten wires ; although inserted into the beam only during the time required for tuning, and in addition protected by an automatic chopping with a pulse length adapted to intensity, ion species and energy, these monitors are very fragile and would neither allow a tuning nor, a fortiori, a permanent control at full intensity . In addition, the geometrical beam loss is about 5% per monitor. Beam profile monitors based on the ionization of the residual gas have been developed at GANIL[4]: the positive ions are guided by a transverse 300- to-1000 V/cm electrostatic field onto a microchannel plate (MCP) amplifier, the output of which is connected to a multistrip anode (figure 2). These monitors are already in use in the experimental caves and they can measure intensities from about 10 enA to several tens of μA ; as a test, we have installed 4 such units in beam lines L2 and L3 (figure 1) but a number of problems remain to be solved :

- their volume is important and, for the moment, they cannot in many cases replace the present monitors without modification of the vacuum chambers ; studies are underway to reduce their size without reducing significantly their resolution

- the polarization voltage of the MCP must be controlled in case of a change of pressure or intensity, to avoid severe damage

- a background is always present in the signal and inherent to the presence of the beam : it is due partly to the X-rays and maybe to the high energy component of the recoil ions, which are not properly focused on the MCP.

These diagnostics cannot operate with low energy beams, due to the presence of the transverse electric field. Therefore, their use will be restricted to the intermediate energy section L2 between the two SSC and the high energy section L3 (figure 1) . In the lower energy section L1, we have ordered 10 units of a modified version of the spiral scanner developed at Dubna. The first model was just delivered at GANIL last month and is presently being installed , but tests were previously made on a prototype, especially to reduce the electronic noise. These beam profile monitors , with a 0.5 mm diameter tungsten wire, are not really non interceptive , but they can stand much more than the maximum power in this beam line (see table 2).

Through data processing, these sensors will give access to several parameters : beam center of gravity and transverse dimensions, etc.... which can be injected in automatic alignment and focusing processes . They will also

be used as to supervise the beam behavior in the course of the high intensity operation.

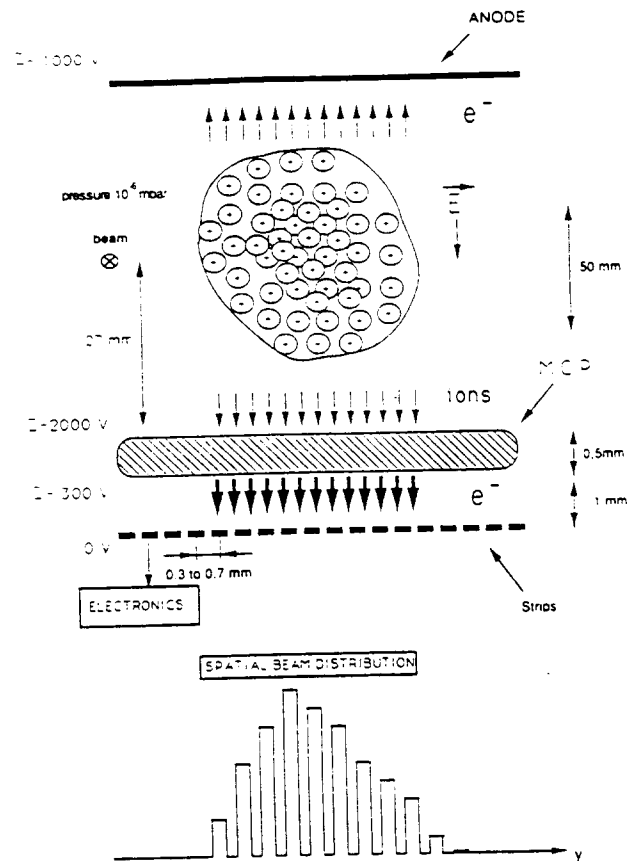

Fig.2. Working principle of the monitor (from ref.[4])

3.2 Dedicated sensors for detection of beam losses

In the low energy beam line L1 where the beam power is limited to about 100 watts and the energy to 1 MeV/n as shown in Table 2, there is no problem as far as the safety of the components is concerned. Inside the SSCs and in beam lines L2 and L3 it is necessary to have sensors for the detection of beam losses. In the course of *tuning*, these sensors must deliver a signal proportional to the loss which can therefore be minimized wherever possible. During *operation at high intensity*, any change in direction or focusing of the beam can damage a number of machine components that are not especially protected or cooled. Figure 3 shows an example of ion ranges and density of the power deposited in matter : the density at 13.6 MeV/n is comparable to the one in the Bragg peak at 95 MeV/n : both beam lines have to be protected in the same manner. Therefore, these sensors should then work on a different mode consisting in delivering a fast response if the loss exceeds a given threshold. We have developed a module with a microprocessor associated to each diagnostic, which delivers either a signal within a few milliseconds, or the

logarithmic value of the detected current, therefore allowing to detect very small intensities.

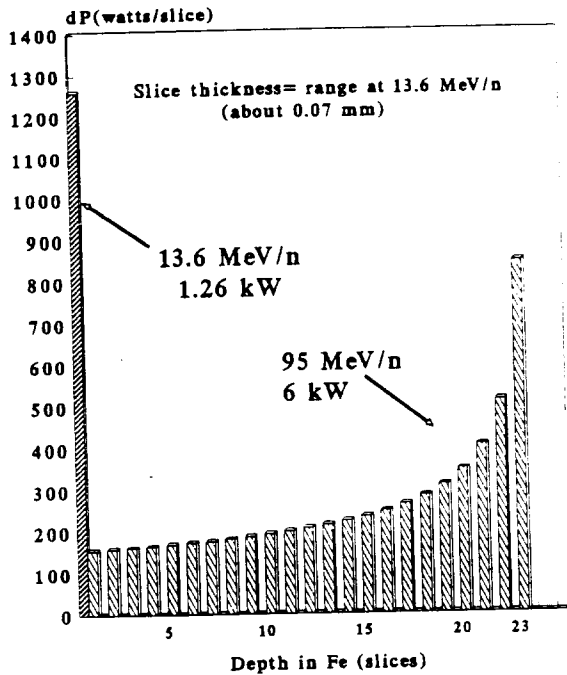

Fig.3. Distribution of the power deposited in Fe by a 1.26 kW, 13.6 MeV/n Ar beam from SSC1 and the corresponding 6 kW, 95 MeV/n beam from SSC2

Inside the two SSC, these sensors are already existing. Up to now, they are only used for the purpose of tuning : they consist of insulated sets of 4-sector electrodes or of diaphragms, made of water-cooled copper and located in front of each injection or extraction element ; they collect the fraction of the electrical current which could be lost at each of these places. In each cyclotron, there are 5 such elements at injection and 5 at extraction.

As for the beam transfer lines, nothing similar is existing for the present time, except inside one of the two superconducting solenoids of SISSI . We started with the idea of using ionization chambers, like the model used at PSI, Villigen : these air-filled, simple chambers would have been distributed outside the vacuum chambers, at strategic locations. However, the problem is more complicated than at PSI, because the variety of ion species and energies makes the production of γ rays different in each case : in addition, there are at least two places where a loss is permanent and therefore constitutes a permanent source of γ ray emission:

- the 4 dipoles of the charge state filter, located after the stripper, where all charge states but one are lost in an already shielded and water-cooled vacuum chamber
- the defining slits and the chambers of the first two dipoles of the α spectrometer, located after SISSI (see figure 1) : when SISSI is in operation, the incoming beam cannot be fully stopped in the production target, due to both the power concentrated on a very small (0.4 mm) diameter and to the power dissipated by the neutrons in the superconducting

windings of the solenoid [5] . Therefore, since the downstream beam line is tuned for the magnetic rigidity of the exotic beam, the slowed down primary beam is lost in the above-mentioned parts. As a consequence, a γ ray detection system is not appropriate.

We are investigating a completely different scheme taking advantage of the fact that each MCP beam profile monitor is shielded by a collimator on the front side preventing halo ions to hit the electrical connexions. This shield will be electrically insulated and divided into 4 quadrants. The principle would then be the same as what exists in the cyclotron.

3.3 Supervision

Supervision already exists concerning an eventual trip of any current supply. However, we had experience of some power supplies showing a written current different from the actual value, because of a failure of the element in the feed-back loop, whether a shunt resistor or a DCCT. The obvious diagnosis for such a failure is to measure the voltage across the load, which is possible provided all suspected elements can be checked when the beam is on.

For instance, all the power supplies of the correcting and harmonic coils (45 per cyclotron) are located in the same room as the SSC, which prevents any on-line test. A new supervision system was then designed, which allows to check the constancy of the two parameters (voltage and current) within a predetermined tolerance. About 100 supplies are already equipped with this system, over a total number of 240. A few high voltage power supplies will also have a double measurement of the output voltage.

Finally, the temperature of the cooling water of some "sensitive" components like collimators on injection and extraction elements, will be supervised.

4. BEAM LOSSES : PROTECTION AND SAFETY

The previous paragraph was dealing with what could be called "active" protection : after a correct tuning, any failure is followed by an action on the beam intensity or at least by a warning. In parallel with this, other actions have to be undertaken which minimize the consequences of beam losses at places where these losses are permanent or may last a certain time.

4.1 Preventing thermal accidents.

In the medium and high energy sections of the beam transport system, as mentioned in paragraph 3.2, some dipole vacuum chambers may suffer important permanent losses (stripper, SISSI, defining slits). They are now internally shielded by tantalum sheets or water-cooled copper shielding, in order to prevent the walls from melting. Another solution could have been to use carbon blocks as shielding, which would have had the advantage of reducing the time for the activity to drop down ; unfortunately, the range of heavy ions in carbon, and therefore the required

thickness would lead to too large a reduction of the width chambers and to an unbearable outgassing.

The water-cooling of probes and Faraday cups still has to be improved, although the use of some of these elements can be avoided during the high intensity operation. They have to be redesigned anyhow, the range of 95 MeV/n deuterons and α particles in copper being much larger than the existing thickness which is appropriate for the present operation with carbon and heavier ions.

There is also a radial probe in front of the electrostatic deflector entrance in SSC2, which precisely investigates the last turns and allows optimizing the extraction efficiency : it is not decided yet if this probe has to be used at high intensity, which would require changing the existing copper electrode for a thin carbon wire.

Finally, the electrostatic deflector of the injector cyclotron was also upgraded and adapted to the new situation, especially by installing a water-cooled shield at the entrance and hiding the insulators as much as possible against metallic vapors.

4.2 Radiation and safety problems.

As for the radiation and safety problems, they only concern the high energy section L3 : upstream of the injection into SSC2, the beam energy is at most 13.6 MeV/n, which does not raise any new radiation or activation problem. For beamline L3 at 95 MeV/n :

- we have now sufficient knowledge about the neutron spectra produced by heavy ion impact and of the attenuation coefficients for concrete; the thickness of the shield around SSC2 and SISSI are now modified according to the expected intensities
- however, an important amount of work is presently devoted to the design of a system that would help to safely remove and to replace a few components that will be highly activated (beam stops, defining slits or Faraday cups) , in case their eventual failure would paralyze the accelerator. The most important " hot spot " is the set of three pairs of defining slits placed at the object point of the α spectrometer ; the design for such a system is underway to disconnect only the jaws of the slits and evacuate them in small lead containers.
- concerning the extraction elements of SSC2, none of them should suffer a permanent loss, thanks to the detection system mentioned in paragraph 3.2 . The only exception is the electrostatic deflector where a small fraction is permanently lost ; hopefully, a fast disconnection device was designed right from the beginning of GANIL so that the whole set can be lift up by a crane and evacuated.

5. THE STRIPPER

Due to the rather high energy at the stripper, the carbon foils must be 100 to 400 $\mu\text{g}/\text{cm}^2$ thick, depending mostly on the incoming energy, in order to reach equilibrium for the charge state distribution. A series of lifetime measurements led us to the conclusion that under the bombardment of a 10^{13} p.p.s., 13.6 MeV/n argon beam, a foil standing still in the beam, would last about 2.5 hours on the average. Actually, this lifetime is not usually

limited by rupture, but by a thickening which induces a slowly increasing energy spread in the stripped beam which itself is less and less accepted by the SSC (as for the mean energy, it decreases slowly, but this loss is compensated by a positive voltage applied to the foil) . Then, although the stripper contains 50 foils, changing to a new foil requires a slight retuning of the machine and such an operation, if repeated with a short period, is not suited to handling high power beams.

In order to improve this situation, it was decided to move the stripper in the beam ; this must in principle make a better use of the total area of the foil : in the present situation, the beam cross section is about 25 mm^2 , as compared to the 300 mm^2 foil area. The whole stripper vacuum chamber is now loosely connected to the rest of the beam pipes through bellows and put in rotation around the beam axis with a 0.1 Hz period. First tests showed that for light ion beams like Ar, the irregularities in the foil thickness have a minute effect on the relative energy loss fluctuation and therefore on the beam phase at the entrance of SSC2. On the contrary, for heavier ions which have larger stopping powers , the beams have larger phase excursion and this phenomenon must be compensated by a feedback action on the polarization voltage applied to the stripper.

Finally, we still have to demonstrate that, with high intensity beams, no thermal stresses develop in the slowly moving foil which could tear it up.

6. THE ADDITIONAL REBUNCHER R2

This element is mostly designed to get a near 100% transmission efficiency for SSC2. The idea is to reduce the radial dimension Δr of the internal beam at extraction by reducing the bunch phase length at injection. Writing up the non-relativistic expression of Δr in terms of the energy spread $\Delta W/W$ and phase width $\Delta\phi$ at injection, (here R is the average radius at extraction and G is the cyclotron energy gain) gives :

$$\Delta r^2 \approx \Delta r_{inj}^2 + \frac{R^2}{4} \left[\left(\frac{\Delta W}{W} \right)_{inj}^2 \frac{1}{G^2} + \left(\frac{\Delta\phi}{2} \right)_{inj}^4 \right]$$

The advantage of reducing $\Delta\phi_{inj}$ with a rebuncher is illustrated by figure 4 : an initial ± 3 mm radial width at injection must not be larger than ± 4 mm at extraction, which leads to a required $\pm 4^\circ$ phase width ; in this example, the energy spread at injection, due to that of SSC1 in combination with the effect of the carbon stripper, is $\pm 7.5 \times 10^{-3}$. In fact, in addition to this buncher effect, an induced precession is also necessary to ease the extraction.

In order to reduce the peak voltage as well as the electrode length and dimensions of the cavity, the fourth harmonic of the cyclotron frequency was retained, which leads to a 27 to 54 MHz frequency range. The tuning in obtained :

- by a movable short circuit for high frequencies
 - by movable capacitive panels at low frequencies
- and a mixing of the two methods is possible for intermediate values [6].

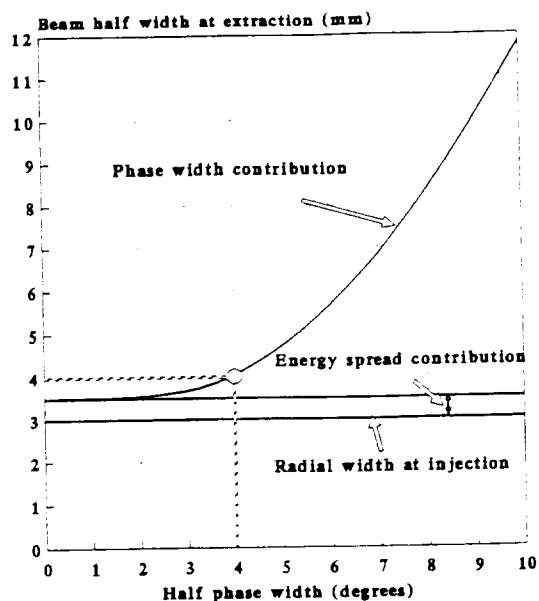

Fig.4. An illustration of the buncher effect on the turn separation at extraction in SSC2

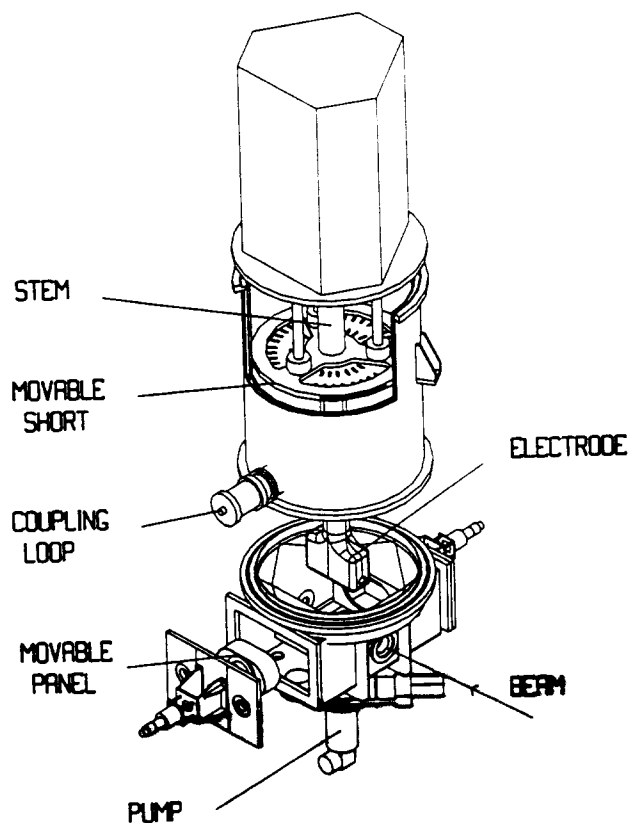

Fig.5. General overview of the rebuncher R2

The high ion velocity at extraction of SSC1 (13.6 MeV/n) requires a 240 kV peak voltage, which implies a 32 kW power consumption. The power supply has already been delivered at GANIL : as for the resonator (figure 5), it should be on the site at the time of this conference for the final acceptance tests. The set will be installed on the beam line during the winter shutdown.

7. TIME SCHEDULE

The THI project must be accomplished without any modification of the yearly schedule of the machine, which means that all installations must take place during the regular maintenance shutdowns. The year 1996 will be devoted to a series of tests of the added or modified elements. Meanwhile, computer-aided tuning procedures for alignment and emittance matching are to be developed.

8. ACKNOWLEDGEMENT

Many people are involved in this program and this report, while summarizing their effort, is an opportunity to thank all of them.

9. REFERENCES

- [1] A. Joubert, E. Baron, C. Grunberg, J.D. Larson, W. Mittig and F. Ripoubeau. - The SSSI Project: an intense secondary ion source using superconducting solenoid lenses. IEEE Particle Accelerator Conference, San Francisco (1991) Vol.1 pp594-597.
- [2] M. Lieuvain, these proceedings
- [3] Ch. Ricaud, E. Baron, J. Bony, M.P. Bourgarel, B. Bru and R. Vienet. Commissioning of the new high intensity axial injection system for GANIL. Proceedings of the 13th Int. Conf. on Cyclotrons and their Applications. Vancouver 1992, p 158. Ed : Dutton-Craddock. Publisher : World Scientific., p446
- [4] R. Anne et al. NIM A329 (1993) 21-28
- [5] E. Baron, L. Bianchi, J. Dural, C. Grunberg. Energy deposited by neutrons and gamma rays in the cryogenic system of SSSI. 3rd European Particle Accelerator Conference. Berlin (1992) Vol. 1, p1555. Editions Frontières.
- [6] M. Di Giacomo and C. Bieth, GANIL internal report 567.94, August 1994