

REQUIREMENTS FOR THE OIL TRANSFER SYSTEM FOR THE PFN'S

H.E.Th. Bakker and P.G. Innocenti

GENERAL

The purpose of the system is (a) to supply the pulse forming networks (PFN) with fresh transformer oil, (b) to provide a storage for reusable oil whenever one or more PFN's have to be drained either for maintenance or in the event of emergency and (c) to allow draining of waste oil from a PFN to oil drums.

DESCRIPTION

The system (see fig. 1) consists of one fresh oil reservoir of 20 m³ capacity and a transfer oil reservoir of the same capacity. Each reservoir is connected to one manifold in the equipment room: connections run from the manifold to the oil bins in which the 5 double PFN's and the master gap assembly are located. The two reservoirs may be identical in construction. Essential features are a manhole a heating element, 4 pipe connections with the following functions : (a) draining of the reservoir, (b) collection of liquid to be sent to the PFN's (this output has a wire mesh filter) (c) new oil input and (d) breathing. In addition temperature and level indicators are provided.

Filling of the fresh oil reservoir is done from an external supply (drums, trucks, etc) by using a pump P₁ which may not be a permanent part of the system. A filter F₁ is mounted at the input of the reservoir.

Emptying the fresh oil reservoir is done either by gravity since the reservoir is mounted above the oil level of the PFN's or by using a pump P₂. In both cases the oil goes through the filter F₂. A non-return valve prevents used oil to flow back to the fresh oil reservoir.

Filling of the transfer oil reservoir, which is placed below the bottom level of the PFN's, is done in two ways :

- (a) by gravity, in case of an emergency, when the solenoid valves S₁ to S₇ are deenergized;
- (b) by gravity, through manually operated valves M₂₅ and M₂₆ when one or more of the PFN's need being drained (M₇ to M₁₂). A filter F₃ is provided.

Emptying the transfer oil reservoir is done by using a pump P₃: The oil flows through filter F₄. Provision is made for discharging waste oil to drums either directly from the PFN's or from the transfer oil reservoir.

By assuming a distance of approximately 20 m from the PFN's to the transfer oil reservoir it appears that the drain by gravity manifold and pipes should have a 4" diameter and the manifold should be connected to the PFN's by a 3" pipe if the emergency draining of the whole system has to be accomplished in 20 to 30 minutes.

Filling of the PFN's is done by pumping the oil through the appropriate filters. A pumping speed of 50 m³/h and pipe diameters of the order of 3" should be envisaged.

Attention is drawn to the fact that freezing of the oil in the pipes will prevent draining of the system in case of emergency.

Fig. 2 shows a possible installation of the reservoirs near the ejection building.

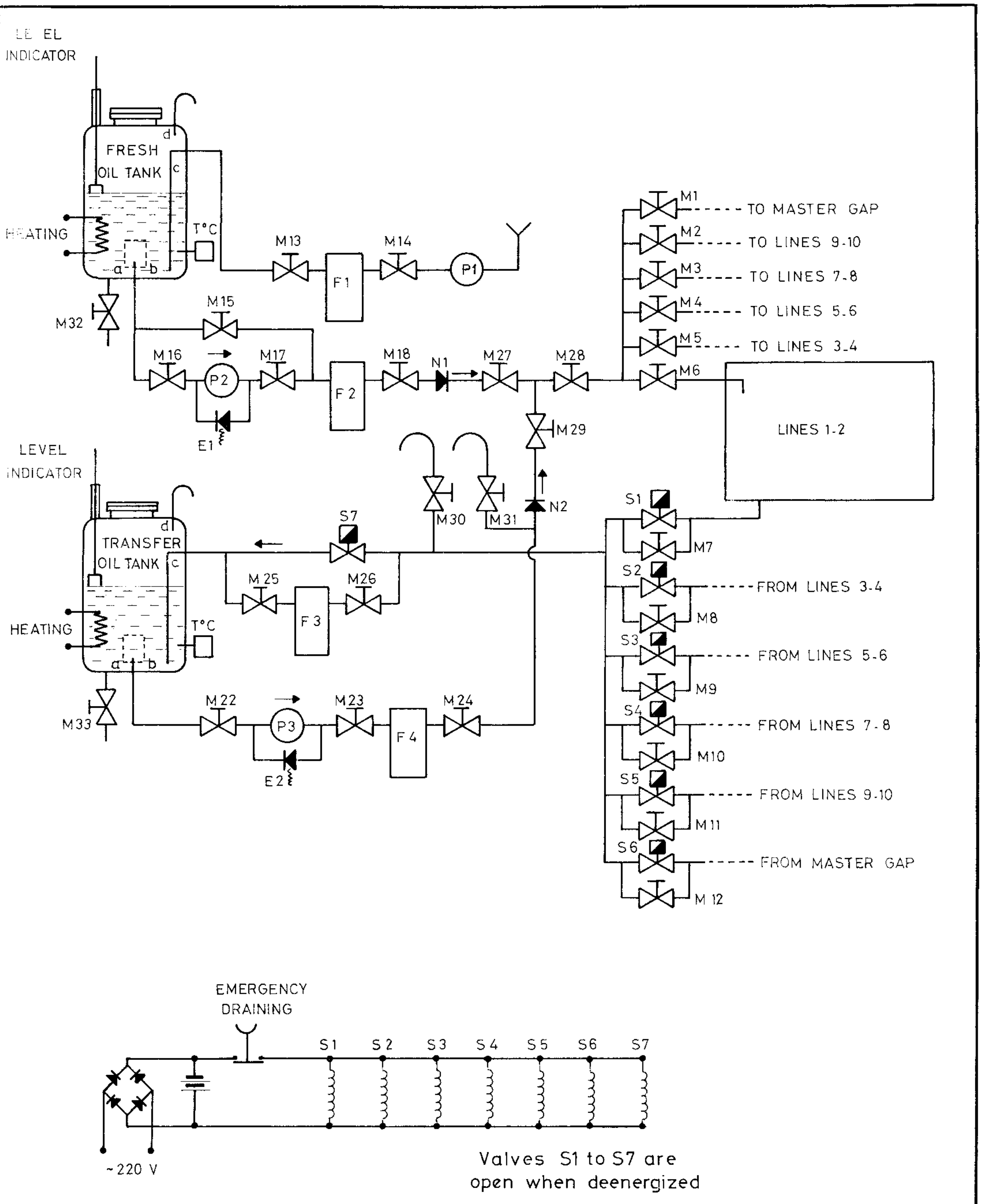

FIG.1
PS.FES/TN 171

OIL FOR DELAY LINES

315.138.3

le 5 Mai 70 ca Babu