

TECHNICAL REPORT

Challenges of the FCC-ee civil engineering studies

L. Bromiley* and R. Cunningham

CERN,
Geneva, Switzerland

E-mail: liam.bromiley@cern.ch

ABSTRACT: The European Organisation for Nuclear Research (CERN) is planning a Future Circular Collider (FCC), to be the successor of the current Large Hadron Collider (LHC). Significant civil engineering is required to accommodate the physics experiments and associated infrastructure. The 90.6 km, 5.5 m diameter tunnel will be situated in the Geneva region, straddling the Swiss-French border. Civil engineering studies are to incorporate the needs of both the FCC lepton collider (FCC-ee) and the FCC hadron collider (FCC-hh), as the tunnel will host both machines successively.

KEYWORDS: Detector design and construction technologies and materials; Manufacturing; Overall mechanics design (support structures and materials, vibration analysis etc)

*Corresponding author.

Contents

1	Introduction	1
2	Feasibility study	2
2.1	Project description	2
2.2	Summary of main structures	2
2.3	Geology	4
2.4	Horizontal alignment	5
2.5	Vertical alignment	5
2.6	Shafts	5
2.7	Caverns	6
2.8	Tunnels	6
2.9	Construction	7
2.10	Thermal heat recovery	7
2.11	Costs	7
3	Conclusion	8

1 Introduction

Upon completion, the FCC tunnel will house the world's largest particle accelerator. The study, currently in the feasibility stage, officially commenced in 2013 following recommendations made by the European Strategy for Particle Physics Update (ESPPU). To support the physics requirements, the CERN civil engineering team has been studying the feasibility of constructing a 90.6 km circumference tunnel project beneath the Geneva region. CERN has a history of completing large civil engineering works to facilitate physics research. When CERN completed construction of the LEP (Large Electron-Positron) in 1989 [1], it was the largest physics facility ever built. This made Europe a worldwide leader in science and technology [2].

To validate the physics case of FCC, the tunnelling studies must satisfy requirements for both a lepton (ee) and a hadron (hh) machine, as well as reuse the existing LEP/LHC infrastructure.

Like the LHC before it, the FCC will extend into the territories of both France and Switzerland. As a result, the main challenges encountered by the civil engineers will be the geological features, local stakeholders, environmental constraints, and project costs.

Geological site investigations are therefore required to validate the geological assumptions made at the conceptual design stage. An initial site investigation campaign is planned to start in 2023 in the areas of highest geological uncertainty.

This paper describes the present state of the civil engineering feasibility studies for the FCC tunnel.

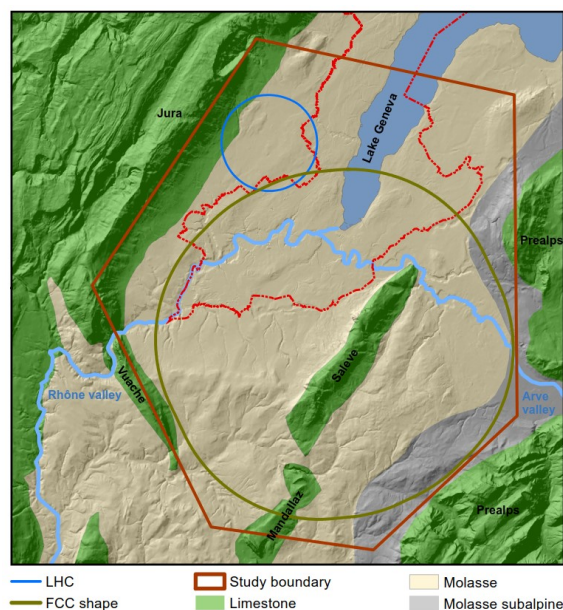

Figure 1. FCC study area. (CERN)

2 Feasibility study

2.1 Project description

Following studies of various locations and geometries of the accelerator machine, the conceptual design of the FCC considers a quasi-circular tunnel, with a circumference of 90.6 km situated in the Geneva basin. The tunnel will be buried underground at an average elevation of 300 m ASL.

In addition to the main tunnel, approximately 10 km of transfer tunnels, 3.5 km of bypass tunnels, 14 shafts, 12 large caverns, 56 alcoves and 8 surface sites are required.

The primary objective of the civil engineering studies so far has been to locate the tunnel within the topographical and geological boundaries of the Geneva basin. While also ensuring adequate connection to existing LHC infrastructure.

The locations of the surface sites have been selected to match the interaction points of the FCC machine layout, but also considering the location of surface access and environmental factors.

Approximately 9 million cubic meters of excavation waste, referred to as spoil, will result from the construction of the FCC tunnels and structures [3]. It is estimated that approximately 95% of the spoil will consist of molasse, which, although it has been proven to be a suitable rock for tunnelling, does not have an obvious potential for reuse. Currently, research is being conducted to examine the possibilities for recycling or reusing the tunnel spoil, rather than resorting to traditional landfill disposal.

2.2 Summary of main structures

- 1 machine tunnel of 90.6 km length, 5.5 m diameter.
- 12 vertical shafts of 12–18 m diameter, 140–400 m depth.
- 8 service caverns, 60 to 100 m length, 15 m high, 25 m wide.

- 2 experiment caverns, 66 m length, 35 m high, 35 m wide.
- 2 experiment caverns, 66 m length, 25 m high, 25 m wide.
- 1 beam dump cavern at point B, 660 m length, 13 m wide.
- 2 beam transfer tunnels from the SPS, 3400 m and 700 m in length, 4 m diameter.
- 20 bypass tunnels, 5.5 m diameter and totaling approximately 5 km.
- 7 junction caverns of varying dimensions.
- 2 Klystron Galleries, one at point H, 2000 m length and one at point L, 1200 m length. 9.8 m span and 5.4 m height.
- 56 electrical alcoves, at 1.6 km spacing around the ring, 35 m length and 10.6 m span.

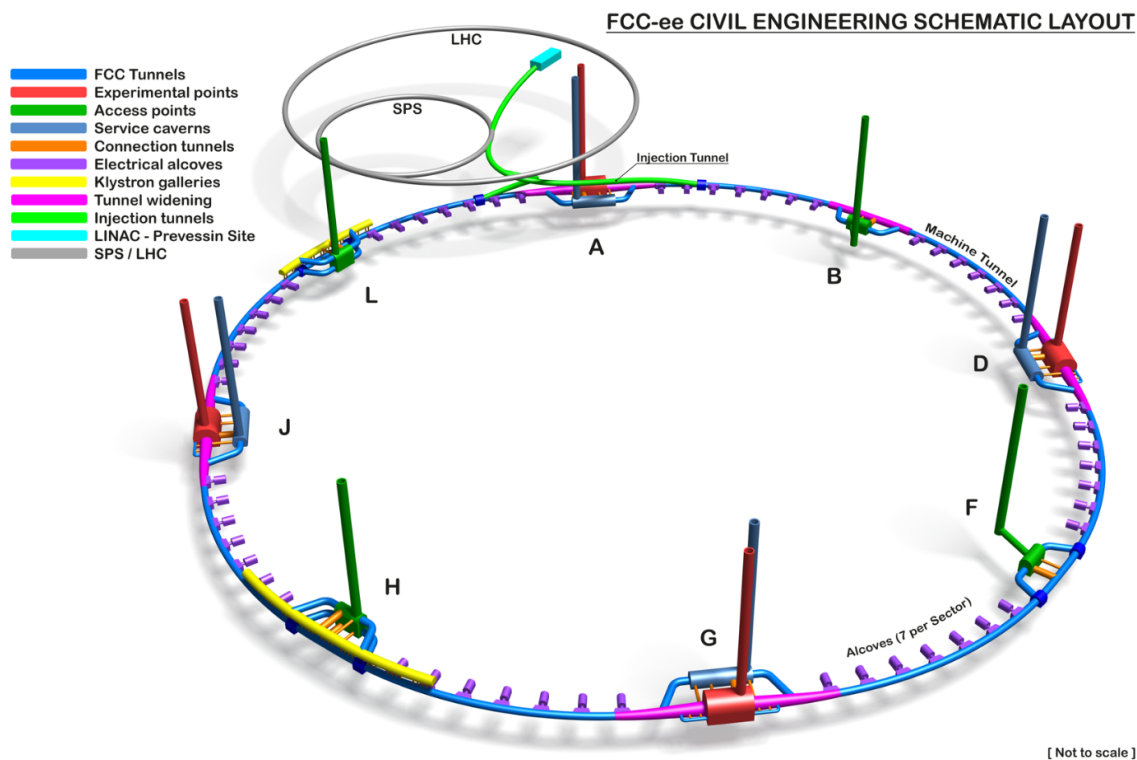

Figure 2. FCC schematic diagram. (Angel Navascues Cornago, CERN)

The structures listed above form the ‘Baseline Design’, which is the infrastructure required for a hadron or ‘FCC-hh’ accelerator. However, the tunnel will also accommodate a lepton collider ‘FCC-ee’ prior to the hadron machine installation. To meet the lepton machine requirements the tunnel will require widening at the four experimental sites, A, D, G, and J. This widening will be to a maximum span of 17.8 m and for a total length of 1100 m each side of the experimental caverns.

The eight underground sites (A to L) require large surface works that will accommodate the necessary infrastructure such as transformers, helium tanks, and cryogenic plants, as well as offices

for operations and management. The four experimental sites will be roughly 6 ha in surface area and the technical sites will be roughly 4 ha in area. Exact layouts of the surface sites are being developed and final layouts will depend on machine requirements as well as local constraints.

2.3 Geology

The Geneva basin has three main ground types: moraines, molasse and limestone. The variable sedimentary rock, called molasse, is overlaid by low-strength glacial deposits, called moraines. The depth of the moraines varies from a few metres up to 100 metres.

The molasse of the Swiss Molasse Basin is composed of horizontally bedded layers of marls and sandstones. The term sandstone refers to cemented sandy or silty rocks and the term marl refers to clayey rocks [4]. These layers can vary considerably in strength.

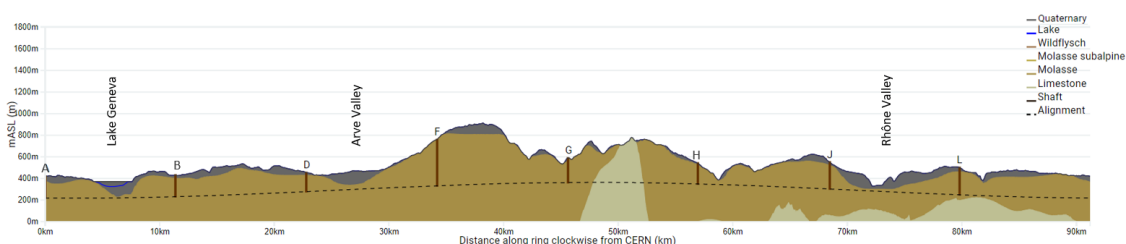

Figure 3. FCC Long section. (CERN)

The molasse is considered a suitable rock type for tunnel boring machine (TBM) excavation, as it is stable and dry; however, the heterogeneity of the rock leads to some uncertainty. Therefore, it is essential that the large span caverns are constructed in stronger sandstone.

Directly under the lakebed, there are very soft deposits which have been identified in previous site investigation campaigns along the proposed alignment. These have been identified as very soft lacustrine clayey silts, and glacial-lacustrine silts and clays with elastic modulus between 2 MPa and 10 MPa, extending from the lakebed to a level of 260 m [3]. Despite little available information for the Arve Valley and Rhône Valley, it is expected that soft deposits, alluvial and fluvio-glacial moraines are to be encountered at depths of up to approximately 100 m below ground level. To avoid construction hazards and the risk of water inflow, the alignment of the tunnel has been lowered by a further 30 m to allow the tunnel to pass through the stronger rock.

There are some known faults within the molasse that will bisect the alignment of the tunnel. The LEP, and before that the Super Proton Synchrotron (SPS), passed through the significant fault of the Allondon near Meyrin, without encountering significant problems during construction. Though, the faults have posed greater problems to the long-term stability of the LEP/LHC tunnels.

Limestone features in the form of the Jura Mountains, the Alpine foothills, the Vuache and Saleve chains border and intersect layers of molasse within the Swiss Molasse Basin. These limestone regions are challenging for excavation due to karstic features formed by chemical weathering of the rock. It is common for the karsts to be filled with water and sediment, which can lead to water inflow and instability during excavation. In comparison to the molasse, CERN has experienced significant issues with excavating in the limestone of the Geneva region. During the construction of the LEP, sector 3 to 4 was excavated in the Jura limestone where there were major issues with water ingress at the tunnel face [2].

2.4 Horizontal alignment

Since the FCC study was launched in 2012 various shapes and sizes for the machine ring have been considered, these have ranged from 47 km to 100 km circumference rings, in addition to less conventional “racetrack” shapes. The smallest options were dismissed at an early stage, despite being the safest choice for civil engineering, because the accelerator wouldn’t be able to achieve sufficient energy levels to realise the experimental aims.

By 2016, a ring with a diameter of approximately 100 km had been adopted by the project team. This ring was initially considered at two distinct positions, one under the Jura, and the other in the molasse basin passing below Lake Geneva. The Jura option was excluded due to the high risk of tunnelling through the karstic limestone with a very high overburden.

From 2016 onwards small variations on the chosen position have been evaluated. In the Geneva basin there is limited scope to place a 30 km diameter ring with adequate connections to the existing particle accelerator, whilst avoiding the undesirable ground conditions. Therefore, the strategy for placement has been to avoid the limestone of the Jura and Pre-Alps, whilst also aiming to minimise tunnelling in the water-bearing moraine layer and keeping overburden to a minimum. As a result, the current location was chosen to align precisely within the limits of the limestone formations and the lake, which becomes deeper in a northeast direction.

2.5 Vertical alignment

One of the main goals of the study has been to design a vertical alignment that places all cavern, tunnel, and other structural excavations in solid rock. These conditions tend to be met by deepening the vertical alignment. However, operation of the FCC and connections to the existing LHC are more efficient with a shallow alignment, so a compromise must be made.

Based on the available information, the vertical alignment has been chosen so that both conditions are satisfied in the best way. This has resulted in an alignment with tunnel ground cover from 50 m to 650 m.

2.6 Shafts

A total number of 12 shafts are required to provide access to the subsurface tunnels. The two transfer tunnels between the LHC and FCC will each require a temporary construction shaft. The 12 permanent shafts will be situated at each of the 8 FCC surface sites, with two shafts (one to the service cavern and one to the experiment cavern) at each experimental location (A, D, G, and L) and one shaft at each of the technical sites (B, F, H, and L).

The vertical shafts will be of various dimensions, from 12 to 18 m diameter. At the time of writing, the specific diameter of each shaft is to be confirmed following confirmation of the machine layout and access requirements.

Because of limitations at the surface, the access shaft to the service cavern at point F will need to be offset from the centre of the machine straight section. A 600-meter connection tunnel will be required to connect the base of the shaft to the service cavern located at point F, in order to avoid residential and access restrictions at the surface.

2.7 Caverns

Sub-surface caverns are required at each of the FCC points, to accommodate the detectors, maintenance equipment, transport vehicles, service infrastructure and access. The experiment sites have both an experiment cavern and a service cavern, spaced 50 m apart. Initial design proposals had the two caverns side by side, with a concrete pillar as support, like the existing cavern arrangement at the LHC point 5. However, to provide shielding from stray electromagnetic fields, the caverns need to be spaced further apart. Consequently, construction risks will also be reduced because of the increased spacing.

At the four technical sites only service caverns are required, connected to the machine tunnel via bypass tunnels. Where tunnels intersect, junction caverns are also proposed, to help the TBM excavate from the bypass tunnels to the machine tunnel.

2.8 Tunnels

As well as the 90.6 km main machine tunnel length, there will be an additional 11 km of tunnels in the form of by-pass, injection, connection, and service tunnels connecting to the main tunnel. These tunnels will range from 3.3 m to 5.5 m internal diameter.

Figure 4 shows the typical tunnel cross section, with the tunnel floor arrangement, ventilation and smoke extraction ducts, and the position of the rail mounted maintenance robot at the tunnel ceiling.

For safety reasons, fire walls and doors will be installed at intervals of 440 meters along the length of the tunnel to create isolated sections. In the event of an emergency, these partitions will enable individual sections of the tunnel to be sealed off, containing the incident and preventing its spread. Additionally, the isolated compartments will provide safe refuge for evacuees to wait for rescue.

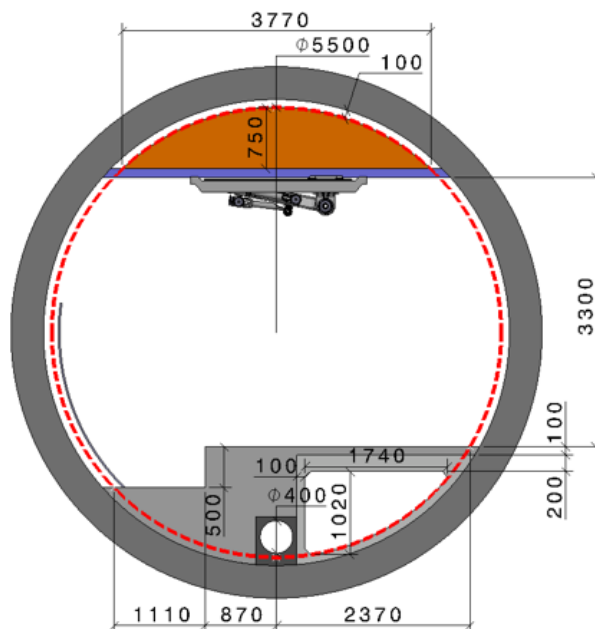

Figure 4. Typical FCC tunnel cross section. (Fani Valchkova-Georgieva, CERN)

2.9 Construction

TBM's will be used for most of the FCC tunnel excavations. These utilise an integrated full-face excavation and support system that is available for various ground conditions. The head of the TBM is equipped with modern systems of excavation which allow high rates of advance while ensuring full support of the surrounding ground. A shield or tail skin provides initial support to the ground and protection to construction personnel [3].

The tunnelling method is driven by the ground characteristics and more importantly, the stand-up time. Soft ground has very limited stand-up time which makes it imperative that the excavation is supported immediately. In comparison, hard rocks allow the excavations to be done in advances up to 4 m, before supporting the excavated void. Choosing between a gripper TBM or a shielded TBM is dictated by controlling the stability of the ground during construction and the expected amount of water ingress [5].

For shorter runs of tunnelling, caverns, alcoves and areas of high geological risk (i.e. areas of limestone), more traditional methods of excavation are employed. Drill and blast is one such method where holes are drilled in the rock face and charged with explosives, which are then detonated and the fallen rock removed. Whilst this method of excavation does not match the speed of a TBM, it allows the rock face to be more closely surveyed and controlled. This is important in areas of geological risk such as the limestone, where encountering karst formations can result in water inflow. Furthermore, drill and blast is essential in excavating irregular tunnel shapes such as for the caverns, junctions, klystron galleries and tunnel widenings where a non-circular tunnel is required.

2.10 Thermal heat recovery

Engineering firm Arup recently finished a feasibility study examining the possibility of recovering heat from future CERN tunnels [6]. The study was focused on incorporating a heat recovery system into the tunnel lining of the Compact Linear Collider (CLIC). Although CLIC is a separate project from the FCC, the results of the study can still be considered relevant to the FCC, as the tunnels of both projects have similar geometries and geological characteristics. Ambient temperature increases with depth below the earth's surface. As a result, it is possible to extract heat from the ground to provide heating for residential and commercial properties. The study investigated the potential heat extraction available from the machine tunnel, considering the geothermal properties of the region and an estimate of the residential heating demand at the surface.

The study concluded that heat recovery systems could be integrated into the tunnel lining, with the potential to generate 10–30 W/m² of output, so long as the system is balanced by storing heat during the summer.

2.11 Costs

Total civil engineering costs were calculated to be around CHF 6 billion by the consulting engineers ILF when the FCC design included 12 points and a machine tunnel length of 97 km [3]. Since then, the FCC layout has been reduced to 8 surface sites and 90.6 km length as described above. Whilst this reduction in scope will reduce costs, a full assessment of the scheme is yet to be undertaken by the consultant ILF, so an accurate cost schedule for the updated design is not yet available.

The original cost estimate produced by ILF included direct costs (materials, equipment, and personnel) and indirect costs (management, support personnel, site preparation, and dismantling). However, it did not include costs for land procurement or spoil disposal.

Material and labour costs were derived from previous project data, equipment costs were taken from the BGL Construction Equipment Register and building costs were calculated in accordance with the BKI Construction Costs [3]. ILF cross checked these estimated costs with the HL-LHC (High-Luminosity LHC) project and other tunnelling projects across Europe.

For the updated 8-point FCC, civil engineering costs are currently being updated as the design progresses.

3 Conclusion

The conceptual design for the FCC underground infrastructure is designed to be compatible with both the FCC-ee and FCC-hh, and to accommodate both successively. The tunnel's geometry is determined by specific parameters set by the machine and experiments. The project's location has been selected to achieve the best possible connection to the existing CERN accelerator complex and to be situated in the most favourable ground conditions. However, some modifications may be necessary based on the results of the site investigations planned for 2024. The location, alignment, and construction methods for the FCC will be further refined based on the results of these investigations.

References

- [1] *The LEP Story*, CERN Press Release, <https://home.cern/news/press-release/cern/lep-story>.
- [2] H. Schopper, *LEP — The Lord of the Collider Rings at CERN 1980-2000*, Geneva, Springer (2009), [10.1007/978-3-540-89301-1](https://doi.org/10.1007/978-3-540-89301-1).
- [3] ILF, *Cost and Schedule Study — Phase 3 Report*, Tech. Rep. EDMS 2050504/1, CERN, Geneva (2018).
- [4] E.J. Fern, V. Di Murro, K. Soga, Z. Li, L. Scibile and J.A. Osborne, *Geotechnical characterisation of a weak sedimentary rock mass at CERN, Geneva*, *Tunnel. Undergr. Space Technol.* **77** (2018) 249.
- [5] D. Chapman, N. Metje and A. Stark, *Introduction to tunnel construction*, second edition, CRC Press (2018).
- [6] Arup, *Geothermal use of tunnels*, Tech. Rep. [ARUP_202204_CERN](#), CERN, Geneva (2022).