

LL

LBL-36456  
UC-414



# Lawrence Berkeley Laboratory

UNIVERSITY OF CALIFORNIA

## Accelerator & Fusion Research Division

Presented at the 1995 Particle Accelerator Conference,  
Dallas, TX, May 1-5, 1995, and to be published in  
the Proceedings

### Design and Testing of the Magnetic Quadrupole for the Heavy Ion Fusion Program

R. Benjegerdes, A. Faltens, W. Fawley, C. Peters,  
L. Reginato, and M. Stuart

April 1995



CERN LIBRARIES, GENEVA

5W9541

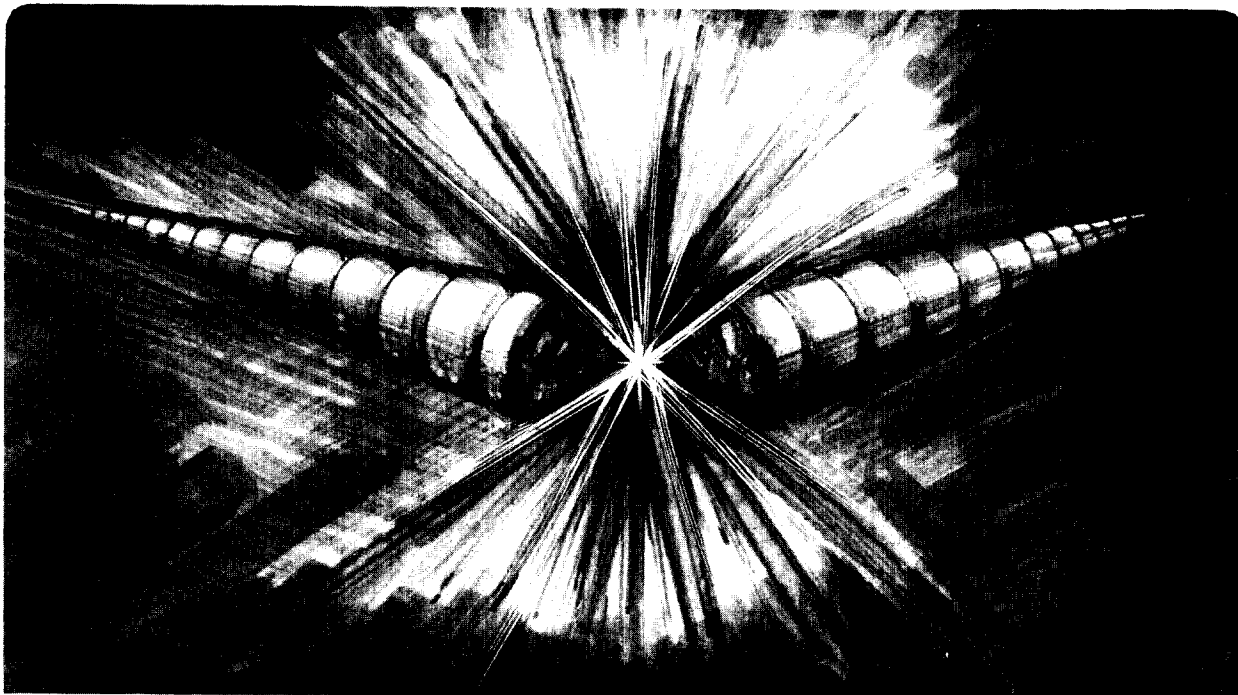

Prepared for the U.S. Department of Energy under Contract Number DE-AC03-76SF00098

#### DISCLAIMER

This document was prepared as an account of work sponsored by the United States Government. While this document is believed to contain correct information, neither the United States Government nor any agency thereof, nor The Regents of the University of California, nor any of their employees, makes any warranty, express or implied, or assumes any legal responsibility for the accuracy, completeness, or usefulness of any information, apparatus, product, or process disclosed, or represents that its use would not infringe privately owned rights. Reference herein to any specific commercial product, process, or service by its trade name, trademark, manufacturer, or otherwise, does not necessarily constitute or imply its endorsement, recommendation, or favoring by the United States Government or any agency thereof, or The Regents of the University of California. The views and opinions of authors expressed herein do not necessarily state or reflect those of the United States Government or any agency thereof, or The Regents of the University of California.

Lawrence Berkeley National Laboratory  
is an equal opportunity employer.

LBL-36456  
UC-414

## **Design and Testing of the Magnetic Quadrupole for the Heavy Ion Fusion Program**

R. Benjegerdes, A. Faltens, W. Fawley, C. Peters, L. Reginato, and M. Stuart

Accelerator and Fusion Research Division  
Lawrence Berkeley Laboratory  
University of California  
Berkeley, California 94720

April 1995

This work was supported by the Director, Office of Energy Research, Office of Energy Research, Office of Fusion Energy, of the U.S. Department of Energy under Contract No. DE-AC03-76SF00098.

# DESIGN AND TESTING OF THE MAGNETIC QUADRUPOLE FOR THE HEAVY ION FUSION PROGRAM

R. Benjegerdes, A. Faltens, W. Fawley, C. Peters, L. Reginato, M. Stuart  
Lawrence Berkeley Laboratory, Berkeley, CA 94720

## ABSTRACT

The Heavy Ion Fusion Program at the Lawrence Berkeley Laboratory is conducting experiments in the transport and acceleration of "driverlike" beams. The single beam coming from the four-to-one beam combiner will be transported in a lattice of pulsed magnetic quadrupoles. The present beam transport consists of high field, short aspect ratio magnetic quadrupoles to maximize the transportable current. This design could also be converted to be superconducting for future uses in a driver. The pulsed quadrupole will develop a maximum field of two Tesla and will be housed within the induction accelerator cells at the appropriate lattice period. Hardware implementation of the physics requirements and full parameter testing will be described.

## INTRODUCTION

The initial transport for the heavy ion beam from the 2 MeV injector to 5 MeV of acceleration is provided by electric quadrupole. At the 5 MeV level, it becomes more effective to use magnetic focusing. The detail of the physics design and requirements of the focusing field are covered in a separate paper at this conference. The electromechanical design of this quadrupole has been optimized for the Elise accelerator. Design codes for a real driver indicate that the optimum design will most likely consist of superconducting quadrupoles and a transition from electric focusing to magnetic focusing will occur at a higher energy level.

## MECHANICAL DESIGN AND MANUFACTURING

The HIF program's magnetic quadrupole has a cylindrical geometry with an aperture radius of 1/3 the effective coil length. The physics design requires a peak field of 2 T over a 1 millisecond pulse delivered at a repetition rate of 1 Hz. The aperture radius has been set at 75 mm, and the effective magnetic length at 249 mm. In an effort to create a magnet that will meet the requirements of a heavy ion accelerator, one prototype has been created and tested and a second prototype is now in progress. In the first prototype we concentrated our design efforts on creating a magnet that would be electrically and mechanically reliable over the short- and long-term. In the second prototype, which we are currently building, we are

refining the design so as to improve the magnetic field quality of the magnet.

The magnetic quadrupole is made up of a coil form, the conductors, electrically insulating-heat conducting epoxy, cooling passages, and a flux return yoke. See figure 1. The coil form is a plastic cylinder in which elliptical ended "race-track" shaped grooves are numerically machined into so as to provide precise positioning of the conductor cables. The quadrupole has 24 turns per pole, arranged in two layers with identical azimuthal distributions so as to provide the 130 kA-turns per quadrant necessary for producing the required 2 Tesla. Rectangular litz wound cable is used as a conductor so as to minimize eddy current losses. Once the conductor has been wound into the coil form, the assembly is vacuum potted with thermally conductive epoxy. A 3 mm layer of epoxy radially distant from the conductors and coil form is left so as to provide electrical insulation between the conductors and the water used to cool them. A cooling jacket is made by stacking a number of PVC rings, which had a step cut into them and off set holes to provide a water passage, which are slid over the magnet. The I.D. of the PVC rings is such that there is an interference fit with the outside of the potted magnet. The whole assembly is then potted into a yoke constructed of steel laminations.

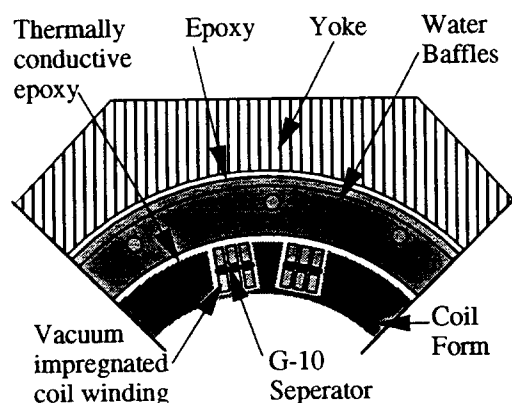

Fig. 1 Cross-sectional view of one quadrant of the Magnet

Making the first prototype electrically and mechanically reliable meant minimizing the voltage across the leads, providing enough insulation between the cables, and providing enough cooling and conductance of the heat generated by the cables. Electrical breakdown problems were dealt with by vacuum potting the magnet so as not to introduce any bubbles and then applying one atmosphere of pressure to the curing epoxy so as to make any bubbles that did exist as small as possible. That way

\*This work was supported by the Director, Office of Energy Research, Office of Fusion Energy, U.S. Dept. of Energy, under Contract No. DE-AC03-76SF00098.

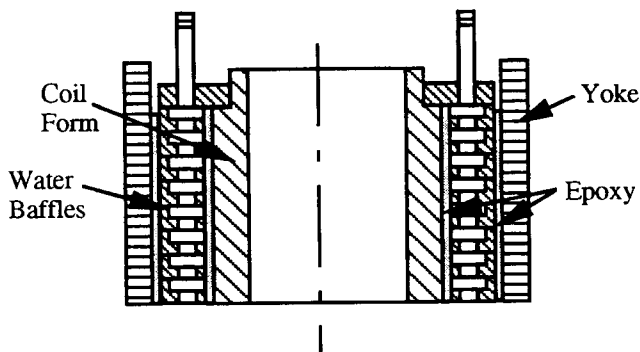

Fig. 2. The Magnetic Quadrupole Cooling Jacket

we would minimize the chance of plasma forming in pockets within the epoxy. Choosing the conductor cross sectional area also had an effect on the potential for break down as well as the chance of over heating the magnet. In choosing a conductor, the ease at which it could be wound and formed was also a consideration. The relationships of conductor size, power dissipation, lead voltages, and number of turns per quadrant of the magnet are shown in figure 2. Also shown in this figure is the fact that the total conductor area must be at least 55% of the cross section in order to obtain correct spacing for the required  $\cos^2\theta$  quadrupole current distribution.

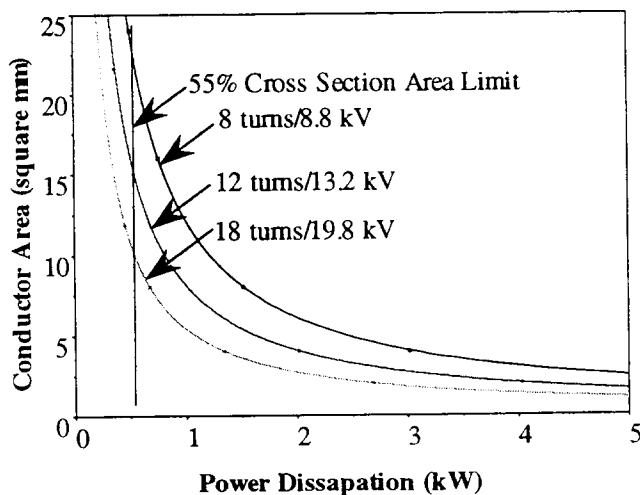

Fig. 3 Conductor size versus energy loss

A reasonable conductor to optimize the power, voltage, and windability equation would be a 3x5 mm stranded conductor. In the first prototype a 3.2 x 6.4 mm litz twisted cable constructed of 7, 14 gage, copper wires was chosen to be used with 24 turns per quadrant. The resulting current was 5400 A and a voltage across the leads of 10.8 kV. Thermal modeling (which assumed a 1.1 kW power loss in the conductors) showed a temperature gain from outside to inside of about 40°C and a maximum inner conductor temperature of 60°C. In the second prototype the stiffer conductor was exchanged for a more flexible conductor of the same overall cross sectional area, so as to meet the more stringent bending requirements necessary for improving the magnetic field quality. The "new" cable is a litz twisted cabled cable constructed of 7 bundles of

13 strands of 26 gage wire. Although the overall cross sectional area of the second conductor remained the same as the first, the actual current carrying area of the cable was reduced by 20%, causing the temperature differential between the water and the inner cable to increase to 55°C. The inner conductor in the second prototype will operate at approximately 75°C.

The design of the second prototype magnetic quadrupole was directed towards manufacturing a magnet with the field quality that will eventually be necessary for focusing a beam of heavy ions in a linear accelerator from an energy of 5 MeV to 10 MeV. The two features of the previous magnet that needed improvement were the path that the conductors took when crossing from one "race-track" across to another, and removing the effective solenoid loop created by the connection of the cable leads at the end of the magnet. See figures 3 and 4. The "cross-overs" of the leads in the first prototype used long gentle curves such that the leads made a "V" shape between each of the race track grooves. Each "V" of the conductor can be represented as an equivalent dipole, which is an undesirable addition to the quadrupole field we are trying to achieve. In order to remove this feature we rerouted the cross over cables such that they make an "X" between the "race-tracks". Due to the geometry of the coil form, the triangle shaped areas formed by the top and the bottom of the "X", which represent effective dipoles, could not be made equal in area to each other. From magnetic calculations it was determined that up to a 40 square mm total difference in the areas between the top triangular shaped areas and the bottom triangular shaped areas, could be tolerated. By reducing the minimum bending radius of the cables to 6.4 mm, and by using a more flexible wire, we were able to meet this requirement.

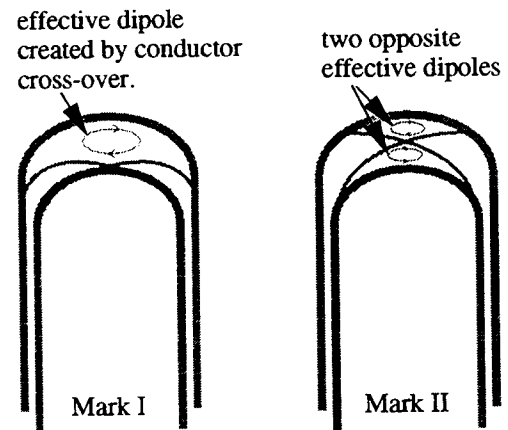

Fig. 4 Changing the coil winding geometry to improve magnetic field quality.

The removal of the solenoidal loop was accomplished by cutting a double helical groove into a piece of lucite rod, wrapping the cable in one groove all the way to one end, making a "u-turn" and wrapping the cable back down the second groove. The whole twisted pair was then heated up and wrapped around a mandrel so that it could then fit around the end of the magnet. The leads from each quadrant would then be spliced into the twisted pair loop.

The results of using a twisted pair loop for the magnet leads is that it will create two solenoids of opposite sign twisted around each other, which will look like a string of very small dipoles with alternating sign. Neighboring dipoles will cancel each others fields out in a very short distance, leaving the magnetic field region in the center of the quadrupole unaffected.

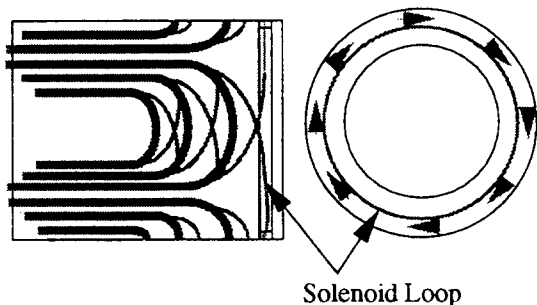

Fig. 5 Unwanted Solenoid Loop

### ELECTRICAL DESIGN AND TESTING

The goal of the electrical engineer is to provide the drive for the magnet which achieves the desired physics parameters with the simplest, most reliable and least expensive power source. In this case, a current of 5,400 A is required to produce 2 Tesla. The Elise beam pulse duration is only a few microseconds at a repetition rate of one Hertz. Hence, the 5,400 A are required with an accuracy of 0.1% for the same beam duration and repetition rate. The optimum system is one which provides the required field with a minimum of power dissipated which dictates a pulsed magnet. The simplest pulser is one which provides a sinusoidal waveform. In order to maintain a constant field of better than 0.1% for 5 ms, a maximum sinusoidal half period of 200  $\mu$ s is allowed. This requirement sets an upper bound on the driving frequency, but the actual optimum is determined by the combined magnet losses which consist of the coil losses, the yoke losses, and the induced losses in the beam pipe and flanges which are frequency dependent. Furthermore, the beam pipe eddy currents must not cause a significant reduction in magnetic flux since this reflects into higher current requirements to maintain the same 2 T field.

A number of tests were performed on the first magnetic quadrupole prototype. A broad minimum power requirement was found at a frequency of 1 kHz. Since the system costs are determined also by the cost of the power supply and associated equipment, it was decided that the period of 500 ms would result in a more costly power supply due to the need of twice the quantity of the series silicon controlled rectifiers (SCR's) for switching the energy. Hence, a half sinusoidal period,  $\tau = \pi\sqrt{LC}$ , of 1 ms was chosen. This lower frequency yields an additional advantage of producing a lower voltage between coil windings resulting in higher reliability. This period produced an ample constant field during beam time and was well within the di/dt ratings of the SCR's.

The simplified block diagram is shown on fig. 6 The charging power supply consists of a six-stage three phase

multiplier circuit which is controlled by solid state switches. Once the desired voltage is reached, the switches are turned off by the comparator.

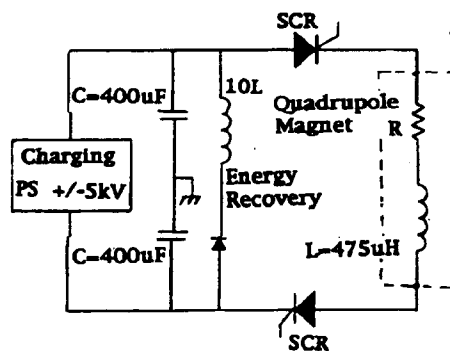

Fig. 6 Simplified block diagram of Pulsed Quadrupole Magnet System

Since the discharge period has been chosen and the quadrupole inductance is known, the power system can now be designed. The period  $\tau = \pi\sqrt{LC}$  and the voltage  $V = I\sqrt{L/C}$ . By substitution we find that  $C=200 \mu$ F and  $V=8.1$  kV. Allowing for cable and SCR losses, we chose a power supply charging voltage of 8.5 kV. In order to achieve higher reliability we have chosen a bipolar power supply of  $\pm 4.25$  kV rather than a unipolar one of 8.5 kV. This reduces the voltage from the pulsed coil to ground insuring higher safety factors at a small increase in cost of the power supply. The total energy (E) required to establish the 5.4 kA is  $E = CV^2/2 = 7.2$  kJ. At one hertz, this would require a 7.2 kW charging power supply. From fig. 7, we can see that at the time that the SCR current is cut-off, 28% of the initial energy has been dissipated in the magnet (including a 1 mm beam pipe and the yoke). The remaining energy returns to the capacitors but with the wrong polarity. It was cost-effective to include an energy recovery system which allowed us to construct a charging power supply 1/3 the size of the system without energy recovery. The inductor and diode shown on fig. 3 recharge the capacitor in the proper polarity recovering 66% of the original energy as shown on fig. 7. About 6% additional energy is lost in the diodes and the energy recovery coil. This magnet was pulsed for 45 minutes at one Hertz and at full current. The temperature rise was well within the calculated values.

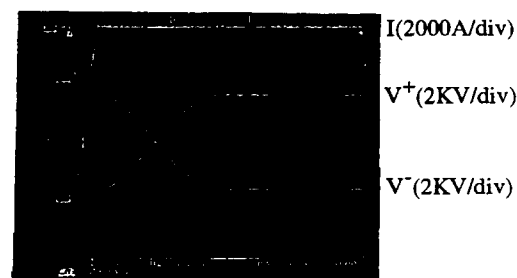

Fig 7 Output current and energy recovery waveforms