

**Replacement of Pulsed Quadrupoles QFO7020, QDE7030
in the AC to AA beam line by a viable spare
and the spare situation for QFO7040**

V. Chohan

The question of spares for these magnets have been raised several times in the past, particularly in the light of the radiation-hard magnet BHZ6024 breakdown in 1991 and considerations of the continued antiproton physics at CERN. The use of the AAC complex for heavy ion intermediate storage would also imply the continued use of these three vital elements. Recently, even some operational experiments have been carried to see the effects of zero current in either QDE7030 or QFO7020 and optimising the other to keep the AAC complex operational; in these experiments [G.Adrian, S.Maury, J. Kuczerowski: 7/6/93, 13/8/93], it was found that (a) with QDE7030 off and optimising the other two quadrupoles, the stacking rate remains extremely poor (~6% of normal situation, so almost a breakdown) while with QFO7020 off and optimising the other two, we can continue stacking at 50% of the normal stacking rate. Hence, it is imperative that the contingencies for these three magnets be worked out and spares be available.

QFO7020 & QDE7030

Both QFO7020 & QDE7030 are identical but function differently in the AC-AA beam line. We do not have any engineering drawings of these magnets which were procured for the ACOL project from the original NP Division's reserves (ex- Bubble chamber beam line?). From the AC-AA beam line drawings, each one uses about 60cm space in this very tight region between the AC & AA Rings. (see copy of AC-AA beam-line drawing attached).

The known characteristics of these magnets (from an old data-sheet given by R.Sherwood) and their desired beam optics needs (see note : PS/OP/Note 86-45 (ACOL Note 47) La Ligne de Transfert AC/AA S. Maury) as well as operational currents for the AC-AA beam line are:

	QF7020	QD7030
Data Sheet values (L60-500):		
Aperture(diameter)	60 mm	60 mm
Iron Length	500 mm	500 mm
Equivalent Magnetic Length	550 mm	550 mm
Maximum Field Gradient	50 T/m	50 T/m
Maximum Current	3 350 A	3 350 A

For the AC-AA beam line:

Field Gradient	14.1 T/m	19.62 T/m
Eq. magnetic length	558 mm	556 mm
Desired(calculated) current	829.5 A	1157.7 A
Operational Current	834 A	1117 A

for check purposes, note that:

current/gradient (datasheet):	67	67
current/gradient (used values):	59	59

Strategy for Replacement of either of these:

We have in Bldg157 (AAC Magnet reserves: B.Pincott/R.Brown) a spare pulsed quadrupole (type L60-400) shorter than these two. The characteristics of this shorter quadrupole (from the data-sheet, ex-NP Division) are:

name :L60-400	
Aperture:	60 mm
Iron Length:	400 mm
Equivalent Magnetic Length :	450 mm
Field Gradient:	50 T/m
Current:	3350 A

In case of the breakdown of QFO7020 (the lower current requirement magnet, 830A), replace it directly by L60-400. In case of the breakdown of QDE7030 (the higher current quadrupole, 1150 A) replace this by the existing QFO7020 and change the connections to make it a QD instead of a QF magnet. Hence under all scenarios, it is the QFO7020 which needs to to be replaced by the shorter spare.

The shortness of the spare has to be compensated by increase in its operational current, if it is to be used instead of the QFO7020. Roughly this increase has to of the

order of (550/450), the ratio of equivalent magnetic lengths; hence the spare would need an operational current of the order of $(550/450) \times 834 \text{ A} = 1010 \text{ Amps}$. The flux density increase at the pole tip is given by $(550/450) \times 14.1 \times 0.03 = 0.52 \text{ Tesla}$; this is largely within the specifications of this spare, short quadrupole. For the purposes of test pulsing current, a value of around 1500 A (<3350 design spec. of the magnet) would be sufficient and R. Brown has organized the logistics of this (bldg195).

The shorter spare has to be physically placed exactly at the longitudinal centre of the longer, existing QFO7020. For the thin-lens approximation in beam optics, this should be valid but in any case, the beamline optics could be re-run using this spare quadrupole as the element; this would give the desired current values (for all 3 quadrupoles) which would then be adjusted for operation in any case. The beam transport program was re-run by S. Maury (13/8/93) with QFO7020 replaced by the shorter L60-400 spare. The result of this gave the following:

QFO7020 (shorter, spare version)	:	16.25 T/m	&	956 A	(calculated)
QDE7030	:	20.03 T/m	&	1182 A	"
QFO7040	:	8.69 T/m	&	86.7 A	"

The support and alignment aspects for the shorter, spare has to be organized for the eventuality of it being used in the AC-AA beam line.

QFO7040

(Type Q50) {Characteristics used for AC-AA beam line: **Equivalent Magnetic length: 500 mm, Diameter: 80 mm, Gradient: 6.48 T/m, Calculated current needed: 64.6 A, operational current: ~51 A**}. This is the type of quadrupole built for the AA-PS TTL2 beam line according to the SPS specifications SPS/ABT/NS/D5-144 of August 1978. The spare type Q50-quadrupole exists in the PS Division, as a reserve for elements in the TTL2 loop and the responsible persons are: J. Delaprisson PS/PA and M. Zanolli PS/PA, from whom further details may be obtained.

Distribution

AR Group
J. Delaprisson
H. Koziol
F. Pedersen
B. Pincott
T.R. Sherwood
M. Zanolli

TYPE L60-400 SPARE (in Bldg 157)

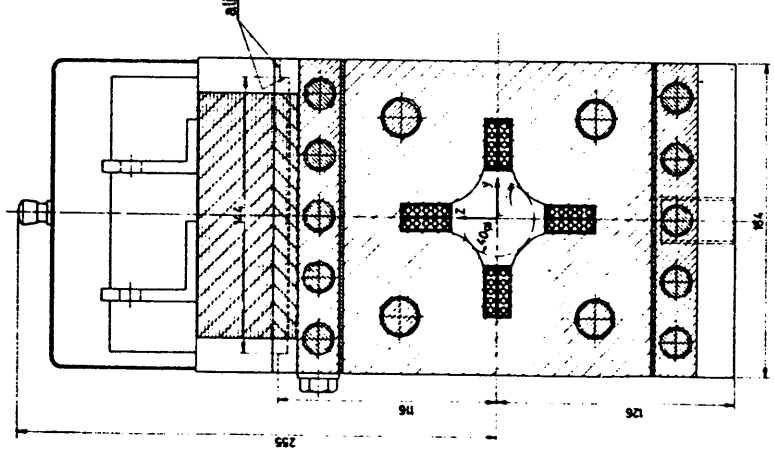
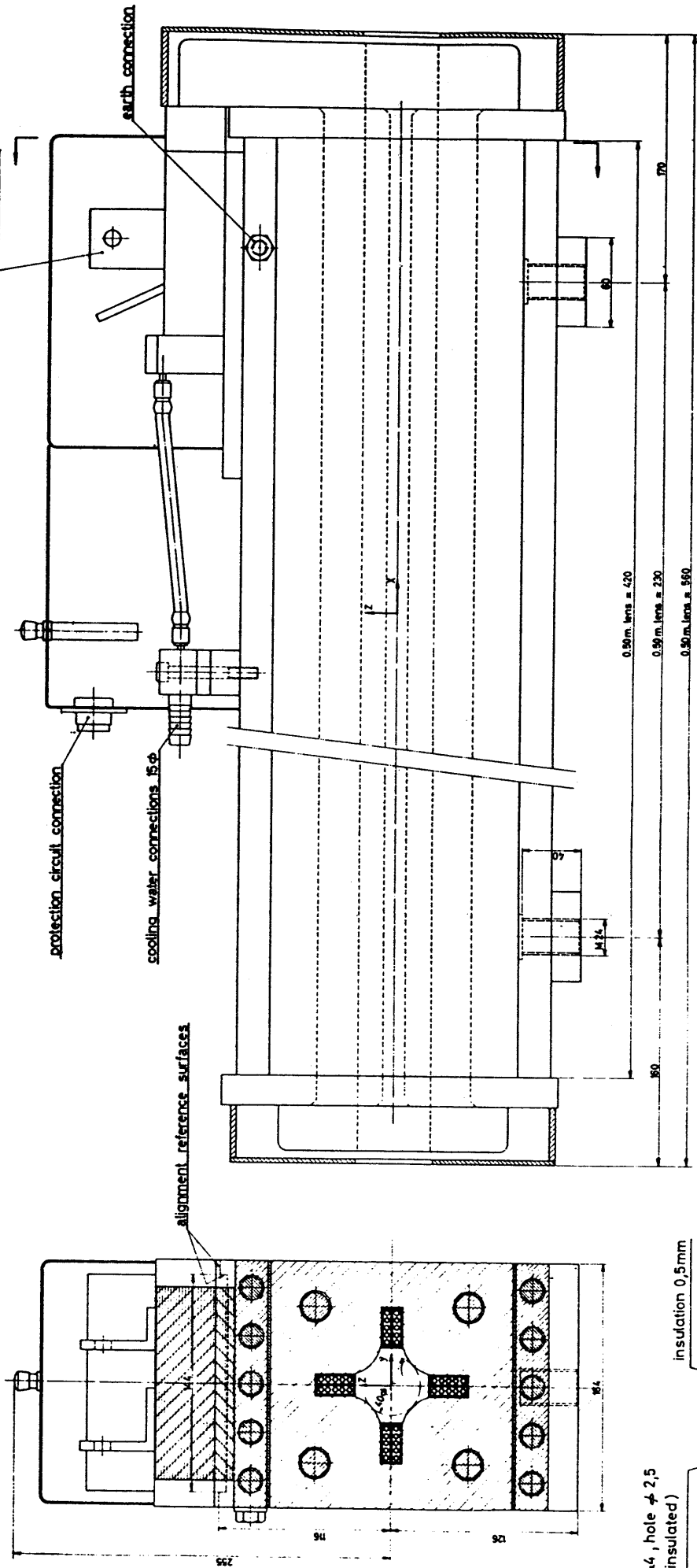

conductor 4x4, hole ϕ 2,5
(5x5 when insulated)

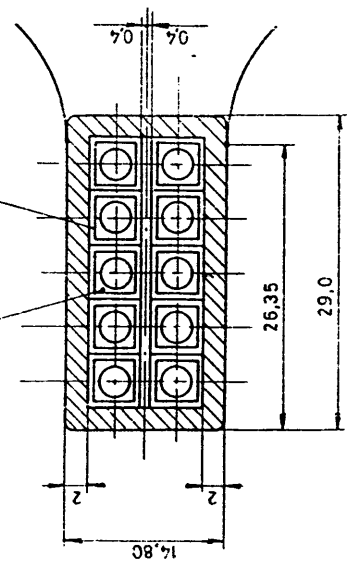
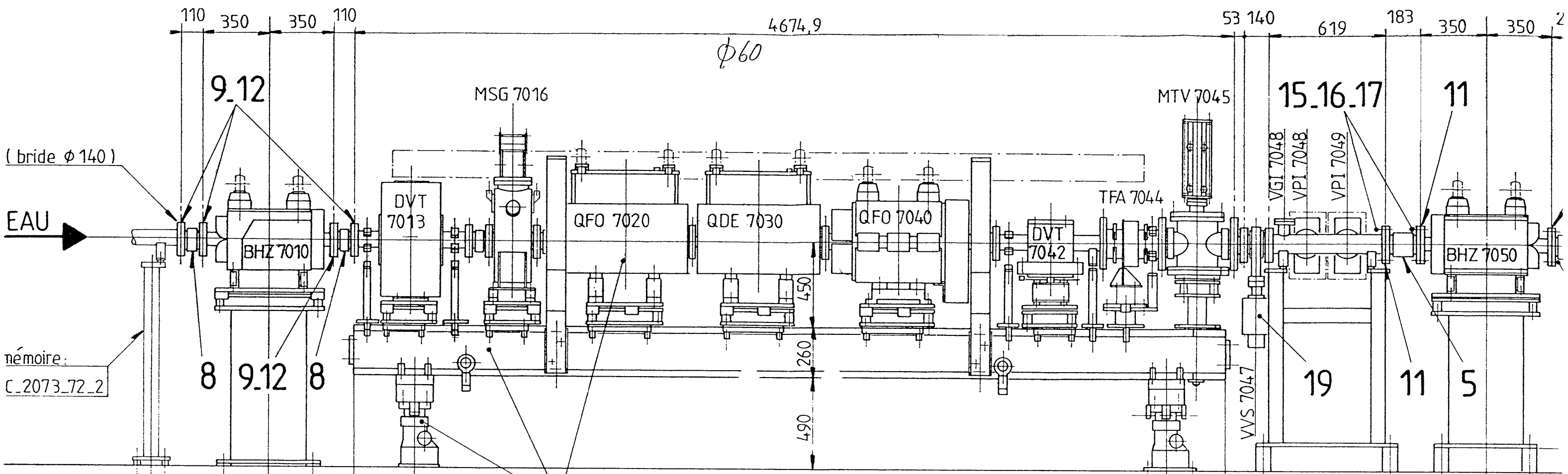

Fig. 5 Sectional view of pulsed quadrupole lens L 40-420

actually installed.
QF 0055/6

There is an L60-400 in store in building 157.



AC TO AA
 BEAM LINE
 (~ 1:20 Scale)

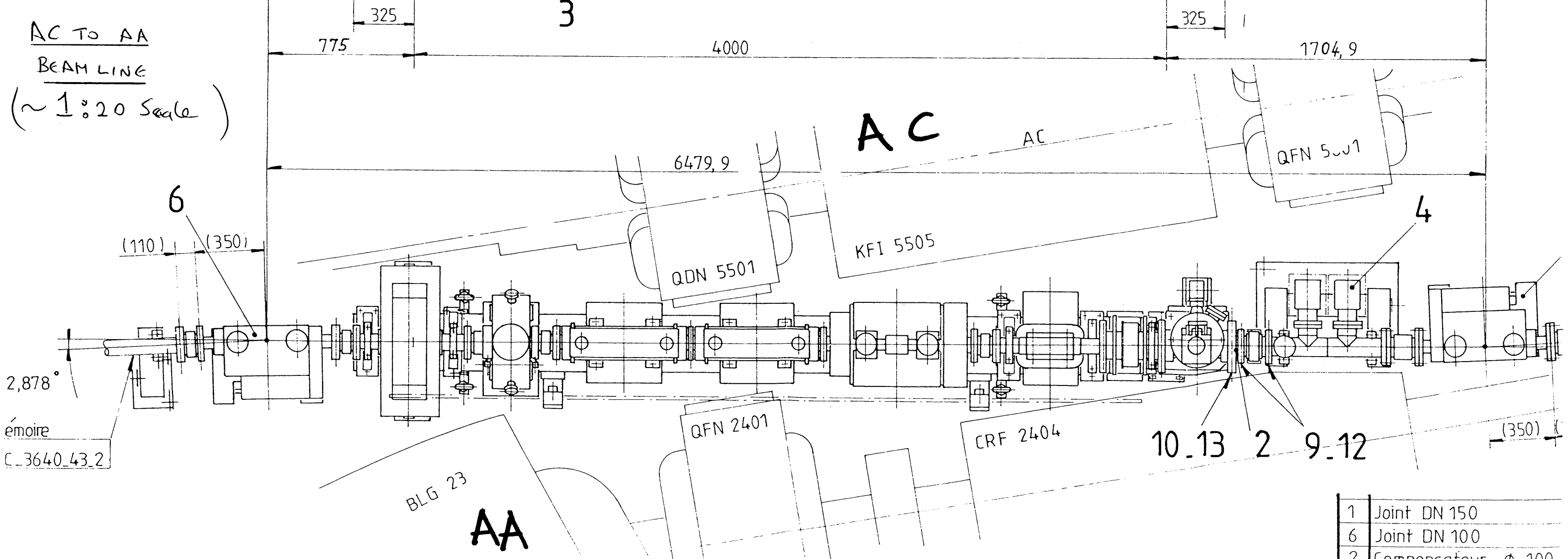

1	Joint DN 150
6	Joint DN 100
2	Compensateur ϕ 100