

STUDY OF THE POWER SUPPLY SITUATION
FOR AN IMPROVED P.F.W. SYSTEM (TEMPORARY SOLUTION)

D. Cornuet, F. Rohner, G. Héritier

SUMMARY

This study shows a possible way of realization of a power supply system for the creation of independent quadrupolar and sextupolar fields in the CPS with the existing PFWs and special backleg windings (figure of 8 loops).

The performance specifications for the three power supplies and a planning for modification and installation work are given. The execution has to be organized in addition to previously defined work and with the help of part time support from other groups.

It is hoped to start the running-in of the temporary solution at the end of the 1976 CPS shut-down. A period of 3 to 6 months may be necessary before the CPS operation can take full advantage of this improvement. It will be possible at any time to resume operation in the present conditions without delay, if necessary.

CONTENTS

	Page
1. GENERALITIES	1
2. CIRCUIT PARAMETERS	
3. PERFORMANCE SPECIFICATIONS	2
4. POWER SUPPLIES AVAILABLE	3
5. POSSIBLE PERFORMANCES OF THESE	4
6. MAIN PROBLEMS	5
7. ELEMENTS FOR A WORKING PROGRAMME	
8. COST ESTIMATE	7
9. TIME SCALE	
10. THE CONTROL OF THE POWER SUPPLIES	
11. CONCLUSIONS	8
FIGURES 1, 2, 3	
PLANNING	

1. GENERALITIES

Considering the time needed for the realization of the final solution (about three to four years) and in order to improve the quality of the C.P.S. beam, a quicker achievable solution has been envisaged using three windings: F and D pole-face windings plus a "figure of 8 loop" (ref. CERN/MPS/SM/Note 74-26 by R. Gouiran). This temporary solution needs, therefore, three power supplies, which are to be found as soon as possible. These power supplies must be very reliable as they have to ensure constant operation with the C.P.S. during at least three years.

2. CIRCUIT PARAMETERS

The electrical characteristics of the three units are determined by the circuit parameters given hereafter.

TABLE 1

Circuit Parameter	Circuit Type			estimate
	F	D	figure of 8 (3 turns)	
Resistance of circuit (Ω)	2.8	2.8	0.6	
Self-inductance of circuit (mH)	24	24	22	
Time constant (ms)	8.5	8.5	36.5	
R.M.S. current max. allowable (A)	140	140	410	
Residual induced voltage (V)	<u>+30</u>	<u>+30</u>	<u>+4</u>	

The differences between the F and D circuits are negligible.

Circuit F (resp. D) consists of 101 series connected focusing (resp. defocusing) windings type "even" paralleled with 101 series connected focusing (resp. defocusing) windings type "odd". (See Fig. 1).

3. PERFORMANCE SPECIFICATIONS

The main characteristics of the power supplies for operation up to 26 GeV/c peak, followed by a flat top at 24 GeV/c which is the minimum requirement for the temporary solution (ref. MAC meeting no. 40, 18.12.1974, MPS/DL/Min. 74-50) are summed up in the following table 2:

TABLE 2

Circuit	F	D	Figure of 8
I_{peak} (A)	440	± 140	700
V_{peak} (V)	1400	± 550	500
$\left \frac{\Delta I}{\Delta t} \right _{\text{max}}$ (A/s)	3000	3000	2500
I_{RMS} (A)	160	140	410
Lowest current (A)	0.2 ± 0.1	$\pm 0.2 \pm 0.1$	0.3 ± 0.15
Resolution rel. to max. current of power supply	$2 \cdot 10^{-4} \pm 1 \cdot 10^{-4}$	$4 \cdot 10^{-4} \pm 2 \cdot 10^{-4}$	$4 \cdot 10^{-4} \pm 2 \cdot 10^{-4}$
Induced voltage from main coil at 10 k A/s (V)	± 30	± 30	± 4
Reproducibility error during acceleration and deceleration (A)	$2 \Delta I_{\text{R}} \leq 4 \frac{p}{28}$ with $p \geq 1.5$ GeV/c (inj. 800 MeV)		$2 \Delta I_{\text{R}} \leq 6 \frac{p}{28}$
Ripple on the flat top	≤ 6 (for low frequency $f < 1200$ Hz)		
$\left \frac{dI}{dt} \right _{\text{max}}$ (A/s)	≤ 60 (for high frequency $f \geq 1200$ Hz)		
Reproducibility error on 24 GeV/c flat top (A)	± 0.1	± 0.1	± 0.15

If it is difficult to have a stable low current below I_{min} (to be defined) a bidirectional blocking system should ensure a zero current up to the moment when I_{min} is required in the circuit. If I_{min} is higher than the value given in table 2, the injection lenses will be used alone during injection time. Thus, at 50 MeV injection all currents will be set to zero (rectifiers at "inversion" or "blocking" state). The power supplies will start to work at around 800 MeV.

4. POWER SUPPLIES AVAILABLE (FOR PROJECT "SPRING '76")

In order to reduce the delay, power supplies already available have to be used as much as possible.

For the F pole-face windings, the "PFW" power supply, at present used, would have to be improved and might do the job together with a small power supply for polarizing at injection. The operators will have to cope with the relatively long response time of this power supply (1200 \hat{A} , 2000 V).

For the D pole-face windings a spare power supply "BRENTFORD type 34" (+460 \hat{A} , +707 V) has been negotiated with Laboratory II. It looks as if it could fulfil the requirements after proper adjustment of the electronics.

For the "figure of 8 loop" a spare power supply "TEKELEC type T704" (700 \hat{A} , 500 V) would be taken from the running quadrupole and sextupole projects (see Fig. 2).

The performance of the temporary system will be limited by the voltage capability of the T704 type power supply. Operation up to 26 GeV/c peak followed by a flat top at 24 GeV/c will be possible.

5. POSSIBLE PERFORMANCES WITH THE CHOSEN POWER SUPPLIES

Remarks about the table on the following page :

Lowest current setting and resolution, present performance

P.F.W. generator : In 1960 this generator was used at 50 MeV injection for correction purposes for low intensity beams (10¹¹ ppp) (but very unstable operation).

Resolution and stability 0.5 A

(improvement of performance by a factor of five should be possible with new static excitation).

T704 : Specified lowest current setting: 1% or \approx 7 A
(can be improved to 0.2 A according to information from Tekelec).

AP 34 : Specified lowest current setting 5 \cdot 10⁻⁴ or 0.2 A
(no modification should be necessary in this respect).

5. POSSIBLE PERFORMANCE WITH THE CHOSEN POWER SUPPLIES

TABLE 3

Power supplies	P.F.W. Generator	Type 34	Type T 704	Remarks
I_{peak} (A)	640	± 200	700	These values are the limits calculated according to the load impedances
V_{peak} (V)	2000	± 700	500	
$\left \frac{\Delta I}{\Delta t} \right $ (A/s)	3000	to be checked	2500	Changes + studies of the PFW generator control to get rid of its auxiliary power supply
I_{RMS} (A)	280	200	410	
Lowest current (A)	0.2 ± 0.1 with 1 auxiliary power supply	$\pm(0.2 \pm 0.1)$	0.3 ± 0.15 after modification	To be checked
Reproducibility error during acceleration and deceleration (A)	To be checked	To be checked	To be checked	
Ripple on the flat top $\left \frac{dI_0}{dt} \right _{\text{max}}$ (A/s)	≤ 12	≤ 3	To be checked	which is twice the specified values
Reproducibility error on 24 GeV/c flat top (A)	± 0.2	± 0.2	± 0.3	
Zero crossing	Not required	Relatively fast (e.g. -0.7A to +0.7A within 50 ms)	Not required	Not defined yet
Transition time during changes of slope $\frac{dI}{dt}$	To be studied	To be studied	To be studied	

6. PROBLEMS

All power supplies will be used under considerably different conditions compared with their initial application. The following items are particularly important:

- high resolution and low current operation $\sim 2 \cdot 10^{-4}$ of I_{\max}
- precise reproducibility despite induced voltages, remanent fields, non-linearities, heating of load etc.
- programming with new function generator (GFA 12 bits)
- response and tracking during changes of slope on main magnet cycle.

These items have a different weight for the various power supplies proposed. The following working programme shows more details.

7. ELEMENTS FOR A WORKING PROGRAMME

The list given hereafter is based on a minimum solution (no remplacement of neither the PFW generator set nor the T704 power supply).

7.1. PFW Generator

- a) Study of new regulator for higher precision (factor of 5)
 - New current and voltage measurement
 - New feed back loops (add current loop, increase gain at low currents..)
 - Introduction of circulation current on the exciter
- b) Manufacture of new regulator
- c) Test of new system
- d) Rearrangement of load connections
- e) Arrangement of new programming (Varian replaced by the GFA)
- f) Manufacture of dummy load (2,8 Ω , 24 mH, 60 kW).

The main work will be done by G. Héritier together with other people of the ED-group.

7.2 Power Supply T704

The commissioning of this system is under way (see Fig. 2).

The following items have to be added now:

- Modification for operation at low current
- Study of problem with induced voltage (the supply cannot produce a negative voltage!)
- Measurements of induced voltage in a figure of 8 loop on the U17 unit
- Study, manufacture and installation of a compensation transformer
- Load connections
- Manufacture of a dummy load (0,6 Ω , 22mH, 100kW)
- Test alone and with the complete PFW system.

This work will be done by D. Cornuet with the help of J. Guillet by delaying the project PS0024.

7.3 Power Supply AP 34

This power supply can be bought immediately as an option on a Lab. II contract. A model with smaller current capability will be available within 4 weeks. It will be installed on the platform of the South Hall extension (see Fig. 3).

The following items have to be considered for the working programme:

- Study and modifications for low current operation
- Study of behaviour with induced voltage on the load at injection and during changes of the \dot{B}
- Study of zero crossing at low speed (dI/dt).
- Improvement of stability on the flat top.

For these studies no support will be available from Lab. II since their programme is already very tight. The work will therefore have to be carried out mainly by D. Cornuet (SM), together with a technician to be defined from the other groups.

8. COST ESTIMATE

It is difficult to give an exact indication for the real costs of the project since part of the equipment is already existing or under construction and modifications are essentially consuming personnel effort.

A rough estimation is given in the table below for a minimum solution.

PFW generator modification, improvement	25' kF
Study and installation of a new PFW patch panel	25' kF
AP 34 power supply	125' kF
Modification of AP 34 power supply	25' kF
Installation, programming facilities AP 34	25' kF
Modification of T704 power supply	25' kF
Dummy loads for tests, compensation transformer	50' kF
	<hr/>
Total	300' kF

9. TIME SCALE

The time scale is roughly indicated in the attached table 4.

It is strongly influenced by the fact that the PFW generator is used for the operation of the PS and will only be available during the short machine stops.

The real loads i.e. the poleface windings will only be available at certain times of the short machine stops.

The figure of 8 loop will only be available after its installation at the beginning of March 1976.

The programme can only be speeded up by the use of MD time for hardware tests.

10. THE CONTROL OF THE POWER SUPPLIES

10.1 The References

It is supposed that the current references (and, if necessary, the voltage references) are produced with the necessary precision by CCI function generators in the neighbourhood of the power supplies:

PFW generator : GFA in the CCR room or PH31
AP 34 supply : " " " " " " "
T704 supply : building 365 (annex electronics)

The way how these references are produced is the responsibility of the CCI group which already has the necessary facilities (IBM, software, consoles, data transmission).

10.2. "Control" and Acquisition

For the T704 power supply (figure of 8 loop), the complete control is planned and no work has to be done in addition.

The control of the AP 34 supply can be done locally since it is only 40 m away from MCR. It can be completed at a later stage (~ 1976) by the CCI group who would manufacture the necessary interface with the STAR system.

The acquisition can be done immediately for voltage and current signals.

The control of the PFW generator can be done partially from MCR by a manual remote control unit. At a later stage the CCI-group can manufacture an interface with the STAR system for complete control and acquisition.

The current and voltage signals are already available on the IBM system but the precision has to be improved.

11. CONCLUSIONS

According to present information it seems to be possible to upgrade the performances of the three existing power supply types such that the specifications given by the MST can be approached. However no margin can be included.

A considerable effort will be necessary to realize the system under the given circumstances (the PFW's and their generator are in continuous operation).

The replacement of the generator set by a static power supply is not considered here but can be planned as part of the final PFW system 2' (ref. MAC meeting no. 43, 15.2.1975, MPS/DL/Min. 75-5).

TABLE 4

ACTIVITY	PERSONNEL	1975												1976											
		J	F	M	A	M	J	J	A	S	O	N	D	J	F	M	A	M	J	J	A	S	O	N	
Manufacturing of 2 loads; 2,8Ω 24mH and 0,6Ω 22mH	1 technic.			0,5	Zahnd																				
Measurement on the 2 loads	1 technic.							1	Martin																
Improvement of the regulation of the PFW generator	1 engineer					1,5	Héritier																		
	1 technic.									3	Adorni														
	1 craftsman																								
Improvement of the control of the PFW generator	1 engineer																								
Installation and control of the "I704"	1 engineer																								
	1 technic.																								
	1 craftsman																								
Study of the "I704" modification	1 sup.tech.																								
Manufacturing of a compensation transformer	1 engineer																								
	1 craftsman																								
Installation of the compensation transformer	1 craftsman																								
Measurements and studies of comp. transformer	1 engineer																								
	1 technic.																								
Installation of the "type 34"	1 technic.																								
	1 craftsman																								
Study of the "type 34"	1 engineer																								
	1 technic.																								
Tests and controls with "I704" and "type 34" power supplies altogether	1 engineer																								
	1 technic.																								
CPS shut-down and installation	2 craftsmen (Régie)																								
Running-in of the temporary solution	1 engineer																								
	1 technic.																								
Study and installation of a new PFW patch panel	1 technic.																								
	1 craftsman																								
General documentation, drawings	1 draftsman																								

The number gives the effectively worked period within the indicated months
 e.g. 2 = 2 months of work within 3 months time
 R = Régie Labour

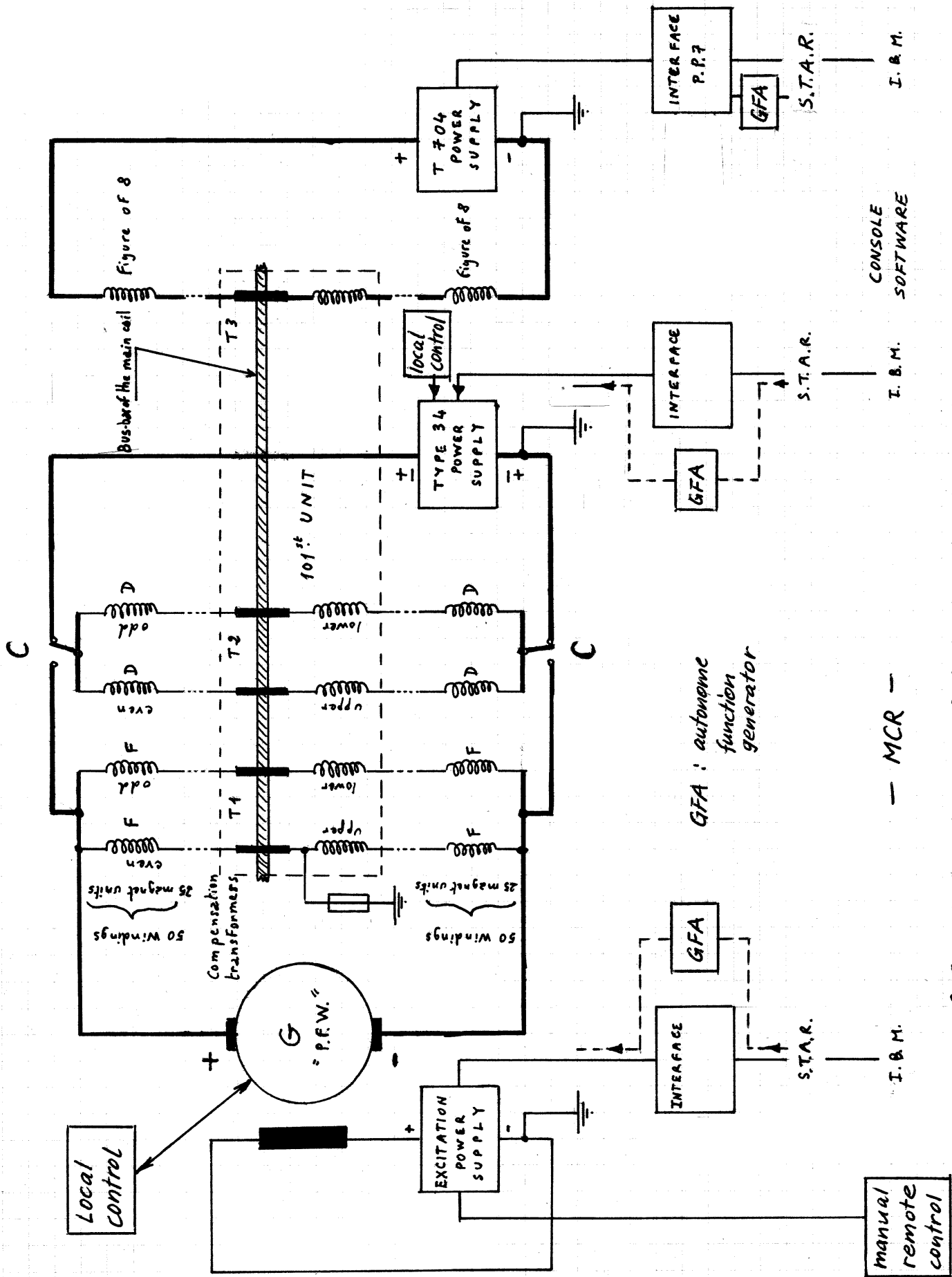

GENERAL CIRCUIT DIAGRAM

CONSOLE SOFTWARE

I. B. M.

S.T.A.R.

S.T.A.R.

I. B. M.

Figure 1
MPS / SM/Note 75.3

- MCR -

I. B. M.

S.T.A.R.

manual remote control

GFA : autonome function generator

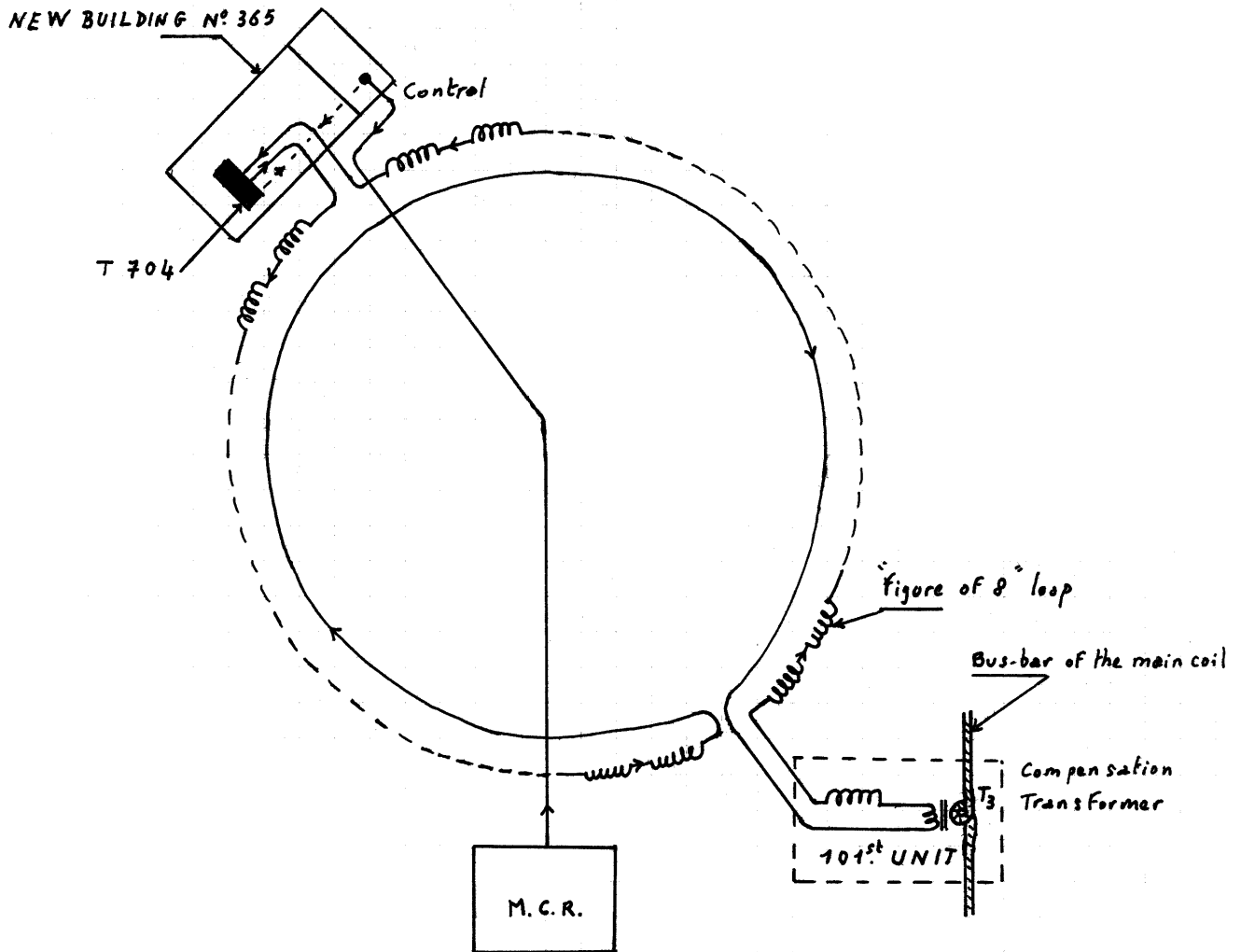

CIRCUITRY FOR "FIGURE OF 8" LOOPS

Figure 2.

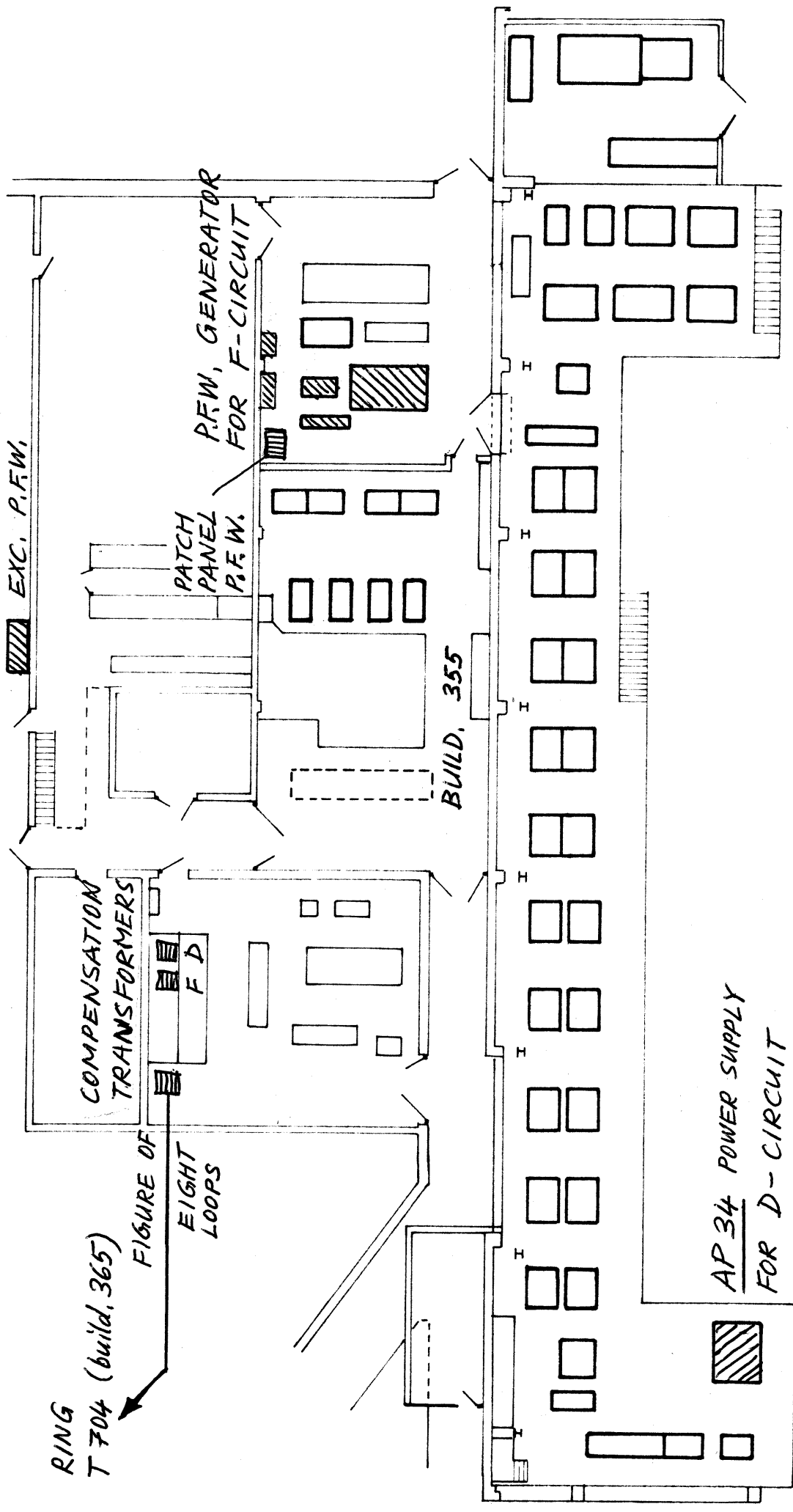

Fig. 3 MPS/AS - SOUTH POWER SUPPLY AREA