

EQUIPMENT FOR SS 84

(3S84-000-3)

A SPECIFICATION

The ss 84 is equipped with one vertical dipole (4C02-200-3) and a non-standard racetrack shape vacuum chamber (3A82-500-4). Both the elements are displaced with respect to the orbit by 20 mm towards the outside of the ring (U. Jacob, F. Rohner).

1. The requirements for precision and stability of alignment of the elements are :

$$\left\{ \begin{array}{l} \pm 1 \text{ mm radially,} \\ \pm 0,5 \text{ mm vertically,} \\ \pm 1 \text{ mrad in angle perpendicular to the beam.} \end{array} \right.$$

It follows that the precision of the initial installation, because of the rigidity of the supporting structure, is only a fraction of the given values.

2. The vertical dipole is a split magnet, which allows the mounting of the element in the PS ring, independently of the vacuum chamber.
3. The vacuum chamber is of racetrack shape (160 x 70) with standard enlarged 4 point quick-couplings.
4. The dipole and the vacuum chamber are sitting on the main support, each having its individual alignment system.

5. The main support is aligned in height to $\pm 0,2$ mm by means of shims. The elements are adjusted in the laboratory to the required height. The angular and radial movements are done in the ring.

6. The vacuum chamber is built on the support and aligned. Then the split dipole is assembled in situ, with the electric and water connections towards the inside of the ring (F. Rohner), and adjusted.

B ALIGNMENT AND ASSEMBLY PROCEDURE

a) Work in the laboratory and workshop

1. Assembly of the vertical dipole on its individual support mechanism.
Alignment in horizontal plane with shims : $\pm 0,2$ mm.
2. Welding of vacuum chamber.
3. Vacuumtest of chamber.

b) Work in the PS ring

1. Installation and alignment of the main support by means of shims. The reference-faces are the two rails on top of the bedplate. The support is displaced towards the outside by 20 mm.

Alignment in horizontal plane : $\pm 0,2$ mm with spirit level and for the absolute height the surveyors.

Radial positionning : ± 2 mm with the jig (3T04-000-S4)

Drawing : 3S84-000-3.

2. Mounting of the vacuum chamber on the main support.
3. Mounting of the dipole on the main support.
4. Alignment of the elements in radial sense with jig (4T-003-2).

ANNEXE : 3S84-000-3

Distribution

E. Boltezar
L. Henry
U. Jacob
P.H. Mann
G. Plass
P. Riboni
F. Rohner
C.E. Rufer

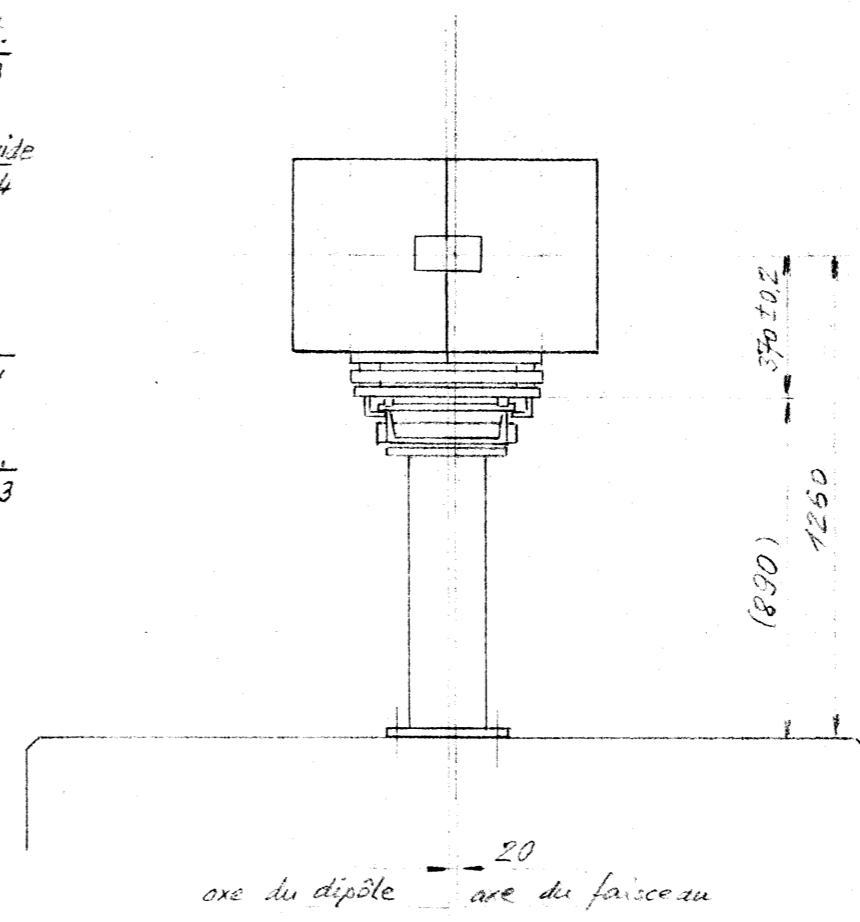
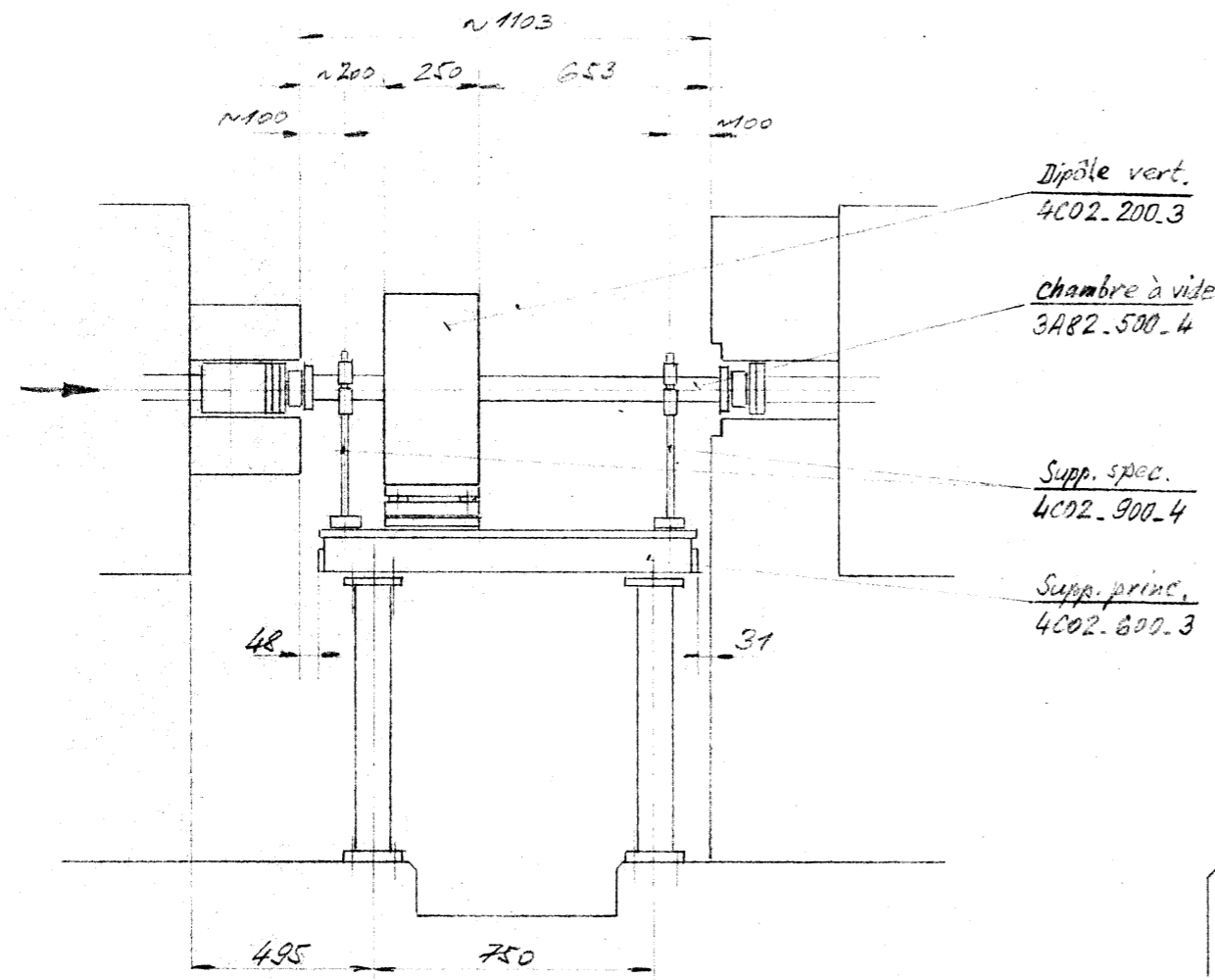

Gabarit d'alignement: pr. dipôle vert.: 4T.003.2

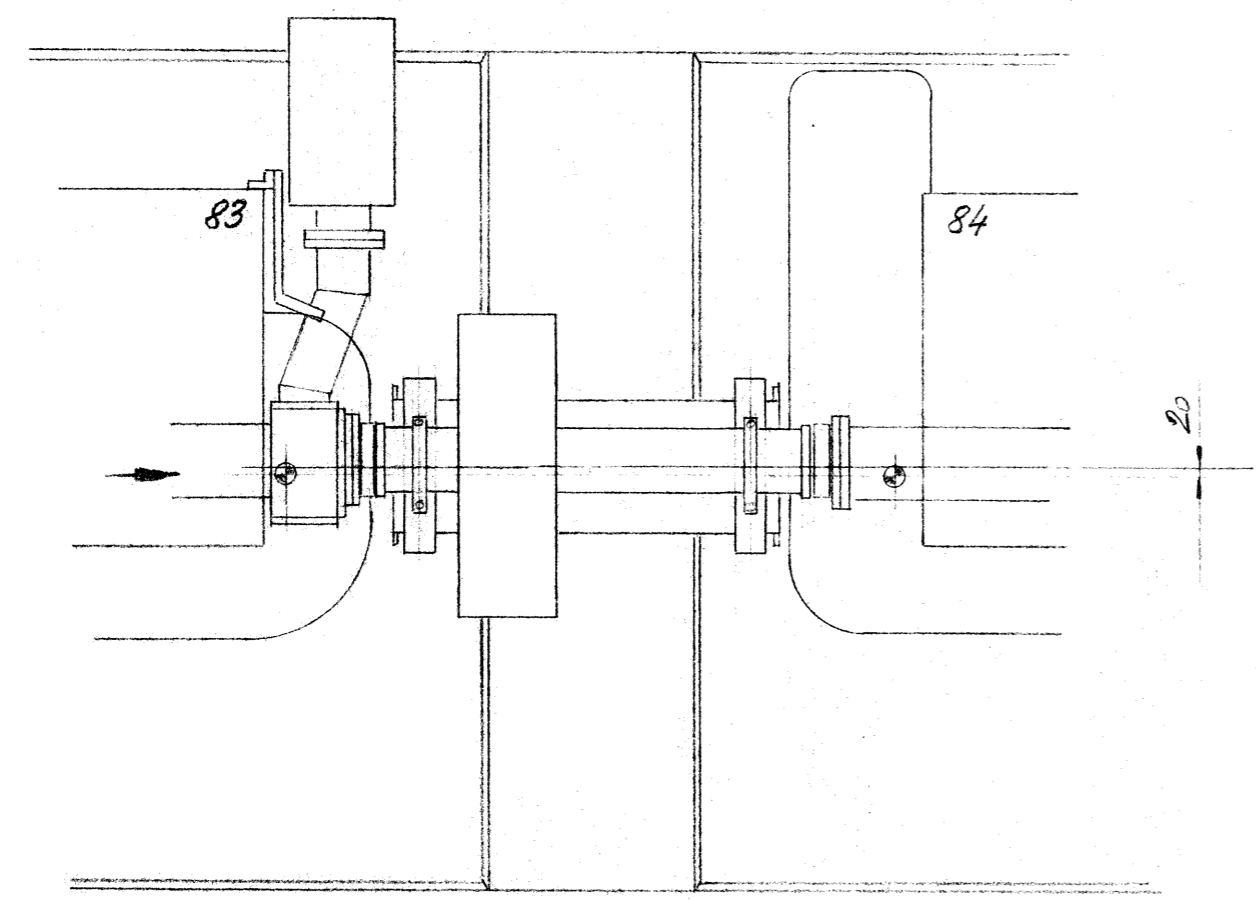

NOMBRE DE PIÈCES	DÉSIGNATION	POS.	MATIÈRE	OBSERVATIONS			
		s.d. 84			ECHELLE	DESSINÉ	12.71
	Dipôle vert. Chambre élargie				CONTROLÉ	16.12.71	Mom
				1:20	VU		
					REMPLE		
					REPLACÉ PAR		
					RÉDUCTION		

CERN ORGANISATION EUROPÉENNE POUR LA RECHERCHE NUCLÉAIRE - GENÈVE

M.P.S.3584.000.3