

CERN/MPS/LIN 71-9
December 1971 - RD/ed

COMPENSATING THE DROP IN ACCELERATING VOLTAGE CAUSED BY THE BEAM

BY MEANS OF AN ELECTRONIC SERVO SYSTEM

R. Dubois

C O N T E N T S

I THE PROBLEM AND ITS CONTEXT

- 1) The need to correct the high voltage
- 2) The old stabilization system

II CHOICE OF A STABILIZING SYSTEM

- 1) The various possible principles
- 2) Advantages and drawbacks

III CHOICE OF THE MAIN COMPONENTS AND DETERMINATION OF THE ELECTRICAL VALUES

- 1) Data
- 2) Choice of components and their characteristics

IV THE PULSED HV BEAM LOADING COMPENSATION POWER SUPPLY (BOUNCER) AND ITS OPERATION

- 1) Practical considerations
- 2) Technological description
- 3) Measurements and results

V OPERATION

VI POSSIBLE IMPROVEMENTS

VII CONCLUSIONS

I THE PROBLEM AND ITS CONTEXT

1. The need to correct the high voltage

The accelerating voltage V_{acc} drops during the emission of the proton beam (i_p) from the source (fig. 1). In fact, the only capacitive energy which is available is the one at the terminal of the accelerating tube (consisting only of $\frac{1}{2} C_p V_{acc}^2$; $C_p = 350$ pF), since the protective resistance R_p , in order to provide proper protection for the tube and its electrodes, does not permit a quick flow of energy from the Haefely filter capacitor.

In a constant-amplitude pulsed proton beam of intensity i_p over a given period t , the drop in V_{acc} is constant and equal to

$$\Delta V_{acc} = \frac{i_p \cdot t}{C_p}$$

The curves in fig. 2 show a few values for this voltage drop as a function of i_p , t and C_p . As the accuracy required for the energy of the protons at the buncher input is ± 500 V, the accelerating voltage must therefore be stabilized.

2. The old stabilization system (Figs 3 and 4)

Capacitor C_c , connected to earth via a high resistance R_3 , is charged by means of a controlled spark-gap. Storage capacitor C_R discharges according to the time constant $(R_1 + R_2)C_c$, equal to the pulse length. The voltage is thus stabilized to within ± 1 to 3 kV by regulating a delay time and the voltage V_c (figs 3, 4).

This system had the following drawbacks :

- 1) a lack of flexibility in adjustment (delay time, V_c , distance between spark-gap electrodes);
- 2) the production of an overvoltage after the passage of the beam, which can

damage the accelerating tube;

- 3) an even higher overvoltage if, when the trigger pulse arrives at the source, the latter does not supply its current pulse;
- 4) the need to readjust the parameters if the source current fluctuates;
- 5) the need to change the value of R_1 or R_2 if the pulse length is to be altered;
- 6) a necessarily excessive voltage V_c , if a long beam pulse is to be accelerated.

The system did, however, have the great advantage of reliability and simplicity (a low breakdown rate during its four years of operation).

This bouncer had to be replaced by another which could :

- 1) correct the high voltage more accurately;
- 2) follow the effect of the variation in the load (i_p, t) produced by the proton current (whence a system which is wholly or partially governed by the accelerating high voltage);
- 3) compensate the effect of a long pulse.

II CHOICE OF A STABILIZING SYSTEM

1. The various possible principles

a) Regulation by means of an overcompensating spark-gap. An electronic tube controlled by a feedback loop absorbs this overvoltage (fig. 5) (the first system adopted by AGS Brookhaven).

b) Regulation by two electronic tubes. The first, with its cathode earthed, pre-triggered and "prepared" before the beam by a programme, controls the second, connected with cathode follower (fig. 6).

c) Arrangement of two tubes in series controlled by two feedback loops (Haefely method for Brookhaven Conversion Program) (New AGS Brookhaven bouncer).

d) A single tube with a servo-controlled cathode, but controlled by an amplifier connected between the grid and the cathode (fig. 7).

2. Advantages and drawbacks

The first three principles involve the use of an h.v. tube associated with a spark-gap, or two h.v. tubes. The principle of system d) is the simplest and the equipment is reduced to the minimum; it is, also, the cheapest. Problems do, however, arise because the signal driving the grid of the tube is transmitted at high potential. Nevertheless, this solution is the one for which we finally opted.

III CHOICE OF THE MAIN COMPONENTS AND DETERMINATION OF THE ELECTRICAL VALUES

For diagram of the chosen circuit, see fig. 8.

1. Data

- amplitude i_p : 800 mA, including the effect of the secondary electrons;
- time (t) of i_p : 30 to 120 μ sec at the source;
- max. fluctuation in V_{acc} : ± 500 V or $\sim \pm 10^{-3}$.

2. Choice of components and their characteristics

a) Tube and capacitor C_c (fig. 8)

Two principal components have to be selected at the same time, viz. the capacitor C_c and the electronic tube.

If $V_{acc} = c^{te}$, $i_c = i_p = c^{te}$ for time t

$$\text{hence } V_1 \approx \frac{i_c \cdot t}{C_c} .$$

The curves in fig. 9 give the values of V_1 as a function of C_c for

the longest pulse duration; $t = 120 \mu s$.

The choice of electronic tube fell upon G.E.C. type EHT7 triode, which has a fairly high amplification factor μ while its price is reasonable. If, however, this tube were to be found unsatisfactory, and in particular if it were found incapable of withstanding a high anode voltage for a considerable time, we have foreseen the bouncer to be equipped with a tube holding a maximum anode of 120 to 150 kV (Machlett type), which would cost very little more (6).

An acceptable anode voltage is 80 kV (max. 100 kV) in order to ensure reliability and to provide a residual anode-cathode voltage of 10 kV, so as not to take the grid of the tube to an excessively positive potential. The voltage V_1 , which is not to be exceeded, is then 70 kV and the permitted capacitance is from 1300 to 1400 pF.

The main effect of such a capacitance is the increase of the energy available at the terminal of the tube (see section 1a) which can, in the case of a breakdown of the accelerating tube, damage the internal electrodes.

The stored power is $W_j = \frac{1}{2} (C_c + C_p) V_{acc}^2$ or, with $C_c = 1300$ pF, $W \simeq 225$ Joules.

With a distance between plates of the same order of magnitude as that between the electrodes of the accelerating tube, and in spite of a large electrode area, the CERN electrostatic separators hold such an energy very well (8). We have yet to make high-voltage behaviour tests on the acceleration column in relation to the value of C_c . This value of 1300 pF seems reasonable, but, to be on the safe side, we have initially taken a lower one (750 to 1000 pF) with a short pulse, even if it has to be increased later if the behaviour of the preinjector so allows.

b) Current supplied by the triode

As the capacitance C'_p is the stray capacitance between the cathode

of the tube and earth, the maximum current output of this tube is $i_c + i_{c'p'}$, or about 1 A (see fig. 8).

c) Value of C_R

This is the storage capacitor charged to V_c , the purpose of which is to provide the required current of 1 A, delivered by the triode. If this voltage V_c is required not to fluctuate by more than 2 kV during the 120 μ sec for which current $i_c + i_{c'p'}$ is supplied, the value of C_R will be :

$$\frac{1 \text{ A} \times 120 \times 10^{-6} \text{ sec}}{2 \times 10^3 \text{ V}} \quad \text{or } 60 \text{ nF.}$$

d) Closed-loop gain

We determined the maximum value of V_1 , which is 70 kV, and also the maximum charging voltage of C_c (see fig. 9). It must be pointed out that this value for V_1 should not be confused with the uncompensated voltage drop ΔV_{acc} (see curves in figs 2 and 10).

The minimum closed-loop gain will therefore be the ratio between the voltage V_1 of C_c and the error voltage ± 500 V, which amounts to 37 dB.

e) Bandwidth of the assembly at 3 dB down (fig. 11)

The minimum pulse length (30 μ sec) dictates the minimum frequency for which the gain must still be maximum (point A on the curve in fig. 11). This frequency is approximately equal to $\frac{1}{3 \times 30 \times 10^{-6}} = 11 \text{ kHz}$.

With a minimum drop of 6 dB/octave on the gain, the upper limit C is found at 700 kHz, at which the gain is zero. By artificially producing a drop of 10 dB/octave, this being the greatest which can be tolerated with a phase shift $< \pi$, we find the point C at 160 kHz, the minimum value for zero gain. It will thus be seen that the whole of the electronic system, including

the delay times between each component and their response times, will have to have a bandwidth of at least 500 kHz (at zero dB gain).

IV THE BOUNCER AND ITS OPERATION

1. Practical considerations (general diagram fig. 8)

The transfer of power to the cathode dome is initiated through the 220V/220V isolating transformer TR4 (see figs 8 and 14). The following operations then take place simultaneously : the tube is heated, amplifier A_2 and generator g_1 are switched on after a delay time of 60 s, amplifier A_1 is also switched on. The bouncer is then ready for operation and the positive voltage V_c may be applied to the anode of the triode. As soon as the SAMES K150 generator which supplies this voltage is started, spark-gap E, which, until this moment, has been short-circuited, opens automatically. The spark-gap has a dual purpose : firstly, it provides increased personnel security since, when the SAMES generator stops, E closes again and thus discharges capacitor C_R through resistor R_K ; secondly, it protects the triode, for the distance between the electrodes of the spark-gap is adjusted so that the voltage at its terminals does not exceed 100 kV.

To continue the start up of the bouncer, first the voltage V_c is adjusted to the desired value, which is higher than the necessary voltage V_1 , and then the cut-off current of the triode is adjusted via generator g_1 . The latter is controlled by a potentiometer connected to a remotely-controlled electric motor, via a long insulating shaft.

Any rapid variations in voltage V_{acc} are detected by voltage divider $\frac{C2}{C1}$ and transmitted to amplifier A_1 , which has a low output impedance, and itself pilots the pulse transformer TR₁ (with 150 kV insulation between windings). The signal is then taken to the input of amplifier A_2 which gives it sufficient energy to allow it to control the grid of the triode, which, having up to that moment been blocked or slightly conductive, now allows the current i_c required to charge C_c to pass in order to keep V_{acc} constant.

2. Technological description

a) General considerations

This high voltage (100 kV) bouncer is then connected to the pre-injector high voltage supply (530 kV). Clearly, if there is any premature arcing at any point in any one of these circuits, overvoltages or transient phenomena, which will hamper the operation and may damage the equipment, may occur in the low-voltage lines. The amplifier inputs, for example, can indeed be protected, but such protection is not completely certain, especially if the overvoltages occurring are as high as several hundred or even thousand volts, even in earth lines, as they may well be.

In order, therefore, to ensure proper reliability, we decided to use electronic tubes rather than semiconductors, even in low-voltage equipment. The only advantage, with semiconductors, would have been a minor one : a slight reduction in bulk, and even then only in a small part of the assembly.

The bouncer assembly may be seen in fig. 16. The cathode dome contains, in the smallest possible space, amplifier A_2 , its output transformer TR2 and supply unit g_1 . Amplifier A_2 (input a few volts, output 1000 V at 4.5 kohms), with its bias power supplies, occupies a space measuring only 10 x 10 x 5 units. The triode is installed in an oilbath to provide the necessary electrical insulation and cooling, which is supplemented by a finned copper cap also serving to stop the X-rays coming up from the tube. The air drawn in by the top fan passes along the fins, enters the cathode dome through louvres and is then blown upwards, cooling the high-voltage tube and its electronic equipment. If the fan breaks down, the electronic circuits and the triode heater are automatically switched off by a thermal circuit-breaker. It should be noted that the ambient air is nevertheless quite sufficient to cool the tube and its fins properly, without the need for a forced draught (oil temperature : 48°C with the fan in operation; 62°C without, designed maximum permissible 70°C at an outside temperature of 22°C). The thermal circuit-breaker thus provides additional safety.

b) Description of the components

i) G.E.C. EHT7 triode

A curve $I_a = f(V_a)$ at $V_g = c^{te}$ has been plotted for the pulsed currents in addition to the tube characteristics provided by the manufacturer (see fig. 13).

The heating voltage has been reduced by 20 % to prevent any possible premature ageing of the tube during operation at 80 kV (reference 6).

ii) Transformer TR2

Intended to reverse the polarity of the output voltage of grid amplifier A_2 .

Transformation ratio	1
Magnetic Circuit	{ Ultraperm torus with a cross-sectional area of 18 cm ²
Number of turns	85
Maximum output voltage	1000 V across 4.5 k Ω
Bandwidth	500 kHz
Rise time (10 % - 90 %)	600 nsec
Flat top	130 μ sec
Drop	10 %

D.C. power supply to secondary winding via a blocking filter; thus the whole of the hysteresis cycle is used while the transformer is in operation.

iii) Amplifier A_2

Voltage	{ input + 2 V maximum output - 1000 V max. across 4.5 k Ω
Repetition rate	2/sec, gain \sim 54 dB
Bandwidth	3 MHz
Volume with power supplies	40 l

iv) Transformer TR1

Transformation ratio	2/30
Number of turns	{ secondary : 2 primary : 30
Characteristic impedance	50 ohms
Insulation between primary and secondary	} 150 kV
Bandwidth	1 MHz (rise time : 300 nsec, flat top : 150 μ sec - drop 10 %).

v) Amplifier A₁

Has a low output impedance, and is designed to feed pulse transformer TR1.

U _{input}	- 0.1 V
U _{output}	+ 55 V loaded by TR1
Bandwidth	1 MHz
Gain	~ 54 dB

vi) Transformer TR3

Is intended to supply the power of 400 to 450 VA for the equipment at the potential of the cathode of the EHT7 tube, including the filament heating. It must be insulated for a pulsed voltage of 100 kV between primary and secondary. After several fruitless tests made on industry-made transformers insulated with Araldite, it was decided to develop this transformer at CERN, with the following characteristics (Ref. 9) :

Primary voltage	220 V
Secondary voltage	220 V
Insulation between primary and secondary	} 150 kV pulsed
Dielectric	oil
Available power	1000 VA

Capacitance between secondary
and primary or between
secondary and earth } 90 pF (windings counterwound on the core)

3. Measurements and results

a) Measurement of the pass band on open loop

i) by direct measurement (diagram and curves fig. 12)

It should be noted that this response curve applies only to a given operating point of the triode, in view of its non-linearity.

ii) by analysing the response to a step pulse

In this analysis, the shape of the output pulse of the bouncer is compared to that of its input step pulse. A FORTRAN programme, called "SNOPSER", is used to analyse this pulse with the aid of the Laplace Transform and gives a harmonic curve $G = f(H_z)$ and a phase curve (réf. 7). A measurement was made by this method, but it was rather doubtful and yielded little that was useful, because the system involved non-linear elements. In fact, in addition to what is mentioned in i) above, the output circuit of the bouncer itself is not linear, either. Capacitor C_c , for instance, is charged in a way dictated by the triode and is discharged with a fixed time constant proportional to $(C_c \times R_K)$.

b) Stability of voltage V_{acc}

See the photographs in fig. 15 and the table giving the operating parameters below.

Operating parameters (maximum)

- Total pulse length $t_1 + t_2$	130 usec
- "useful" pulse length t_2	100 usec
- part removed by chopper	30 usec
- beam intensity at BM02	550 mA
- uncompensated drop u_{acc} with bouncer disconnected	~ 120 kV to 130 kV
- compensated drop u_{acc}	550 V (see photograph - fig. 15)
- stability of V_{acc}	$\pm 0.5 \times 10^{-3}$
- open loop gain	10^6
- closed loop gain	60
- anode voltage of EHT7 tube	80 kV (max. 100 kV)
- V_1 max at cathode	70 kV
- load capacitance C_c	1000 pF

V OPERATION

1. Bouncer connected to 3 MeV experimental linac preinjector

400 hours of operation with a voltage V_c of about 40 to 50 kV and 600 hours with a V_c of 75 to 80 kV, since 1970. The triode tube has not been damaged by any overvoltages occurring when the accelerating column flashed over to earth.

2. Bouncer connected to linac preinjector

Operation since 1.1.1971, 6000 hours at a voltage V_c of 40 or 50 kV, with a 40 to 50 μ sec beam and a source intensity of 450 to 500 mA. Some breakdowns occurred in the SAMES anode voltage generator; on the bouncer itself only, a remote-control relay was destroyed by an overvoltage.

VI POSSIBLE IMPROVEMENTS

Since the stability of the voltage u_{acc} is satisfactory during acceleration, a close look should be taken at the reliability of the equipment (which has been satisfactory so far). If, however, higher precision is made necessary by the 500 keV beam optics, for example, it would be possible :

- to improve the bandwidth in order to obtain a greater closed loop gain; and/or,
- to insert a differential input amplifier into the loop, on the low voltage side, of course. For instance, a programmed pulse, which would compensate 80 % of the voltage drop, would be applied to one input. The feedback loop would be connected to the second input to compensate the remaining 20 %. It would thus be possible for the beam amplitude to vary by 20 % without any change in the programme pulse. Since the latter is assumed to be stable, the closed loop gain, and hence the precision, could be increased by a factor of 4.

VII CONCLUSIONS

When compared with other bouncers at present in service, this equipment seems more compact, simple and easy to repair. Its accuracy is good and adequate for the present 500 keV beam transport system between the preinjector and tank I. It could be improved if needed.

Operation is satisfactory, with a total of half an hour's breakdown time (due to the remote-control relay) during 6000 hours of linac operation with V_c at 40 kV. Connected to the 3 MeV experimental linac preinjector, a second bouncer has operated for 4000 hours with V_c at 40 kV and 600 hours at 80 kV (long pulse without any major breakdowns).

ACKNOWLEDGEMENTS

My special thanks go to Jean Huguenin for his invaluable help and advice during the development of this project.

I should also like to express my gratitude to R. Nettleton, who has taken an active part in constructing the electronic and electrical equipment, and H. Vazzoler, for his work on the mechanical components.

REFERENCES

1. J. Huguenin et al. : The new 500 keV single gap preinjector tube for the CERN proton synchrotron linac. Presented at the Second International Symposium on Insulation of High Voltages in Vacuum, Boston 1966, and the Linear Accelerator Conference, Los Alamos, 1966.
2. T.J.M. Sluyters et al. : A Bright High-gradient 750 keV ion gun, Brookhaven, Particle Accelerators 1970, Vol. 1. pp. 15-25.
3. V. Kovarik (Brookhaven) : private communication.
4. R. Emigh (Los Angeles Scientific Laboratory) : private communication.
5. D. Crepin : Correction de la HT d'un préinjecteur par variation du potentiel d'un écran capacitif à l'aide d'un asservissement électronique, Saclay, SEFS TD 66/57.
6. D. Crepin : private communication
7. H.H. Umstätter : Computer Analysis at Reflected Step Pulses and other Transients - MPS/Int. SR/68-10.

8. D. Simon, R. Michelier : Développements liés à l'étude d'un séparateur électrostatique à plaques multiples. Presented at the IIIrd International Symposium on Discharges and Electrical Insulation in Vacuum, Paris, 1968.
9. Mr. Petithory (S.A. des Ateliers de Sécheron, Geneva) : private communication.
10. R. Dubois : Compensation de la chute de tension due au faisceau. - MPS/LIN/Note dated 11.2.1969.
11. F. Chiari, R. Dubois : Faisceau de protons à 500 keV de longue durée, 100 μ sec - MPS/LIN/Note 70-6

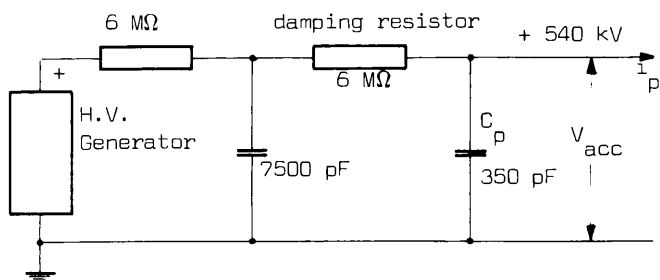

Fig. 1 : Preinjector H.V. Circuit

Fig. 2 : Voltage drop ΔV_{acc} as a function of acc. current

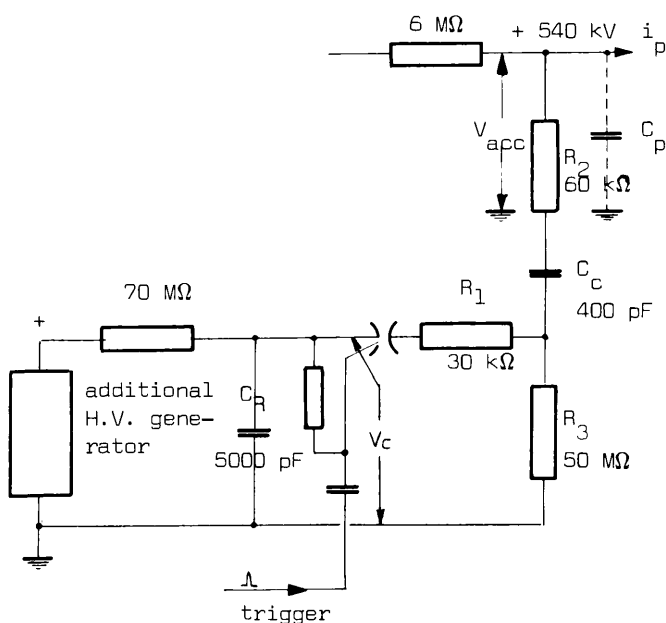
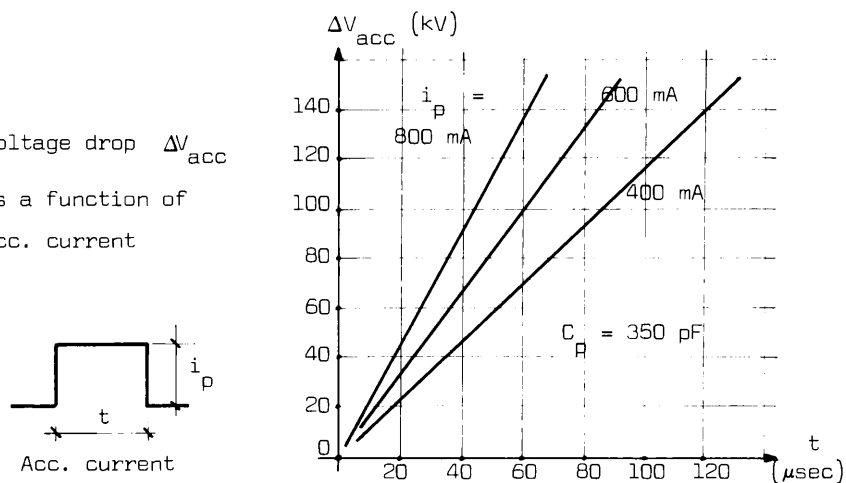

Fig. 3 : Original stabilization system (Values of R_1 and R_2 are for $t = 35 \mu\text{sec}$)

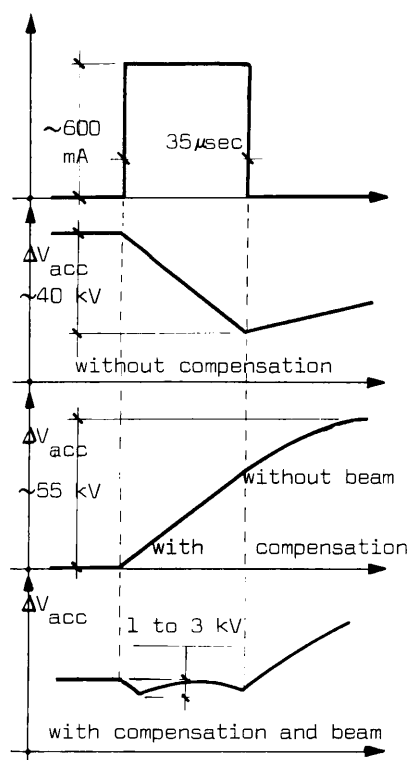

Fig. 4 : oscillographs of original stabilization system

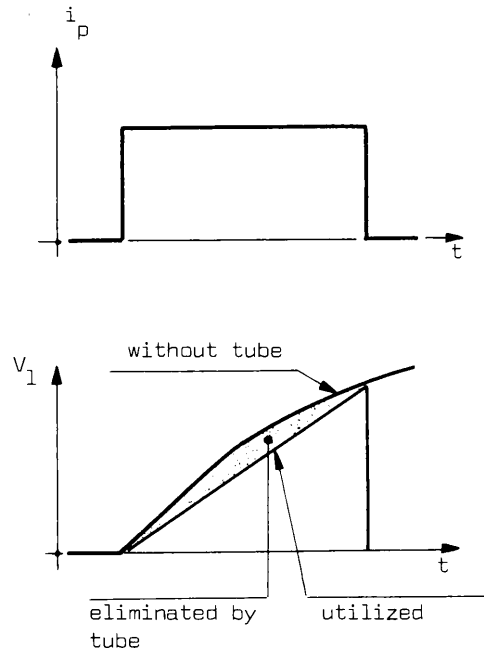
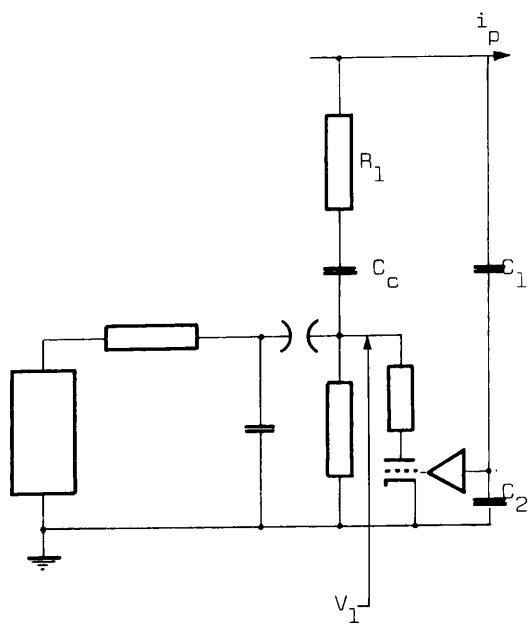

Fig. 5 : stabilization system with tube and spark gap.

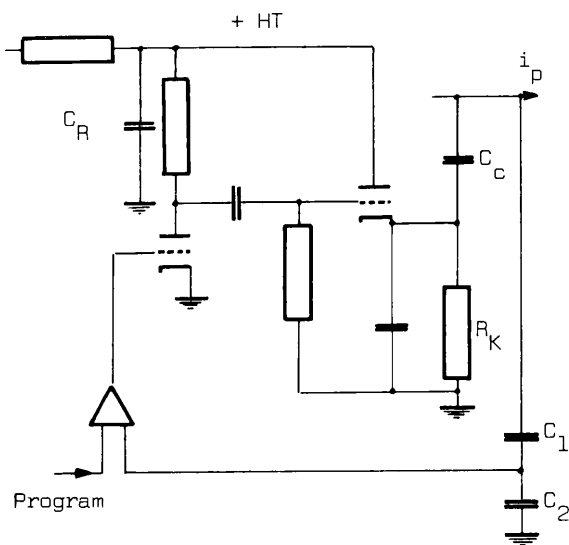

Fig. 6 : 2 tubes system

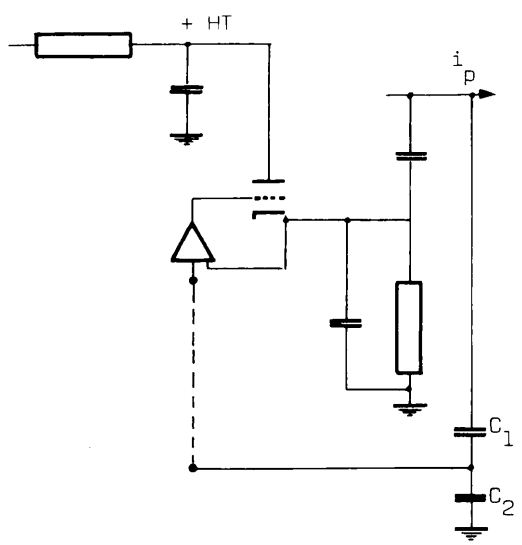

Fig. 7 : preferred system

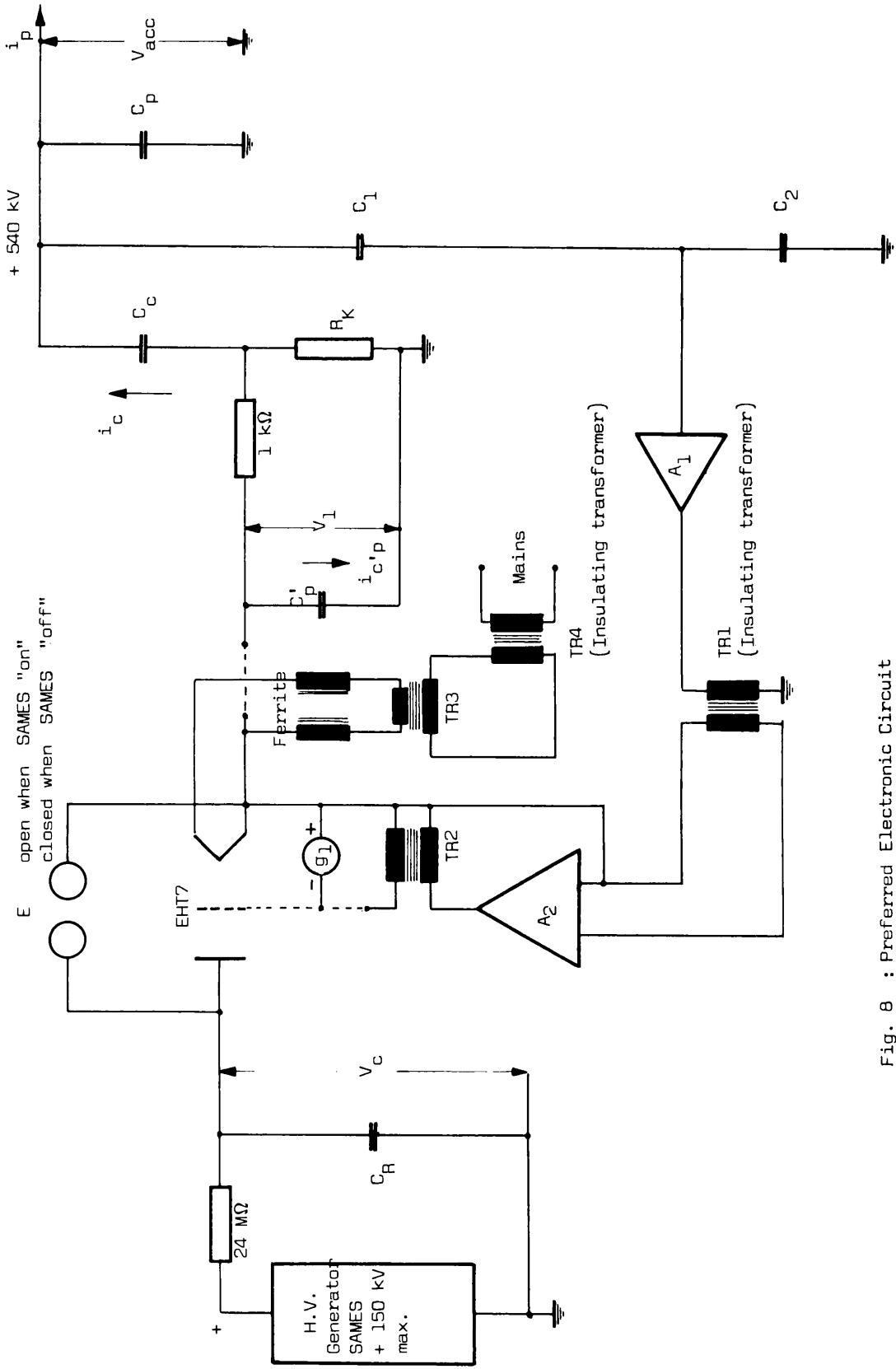

Fig. 8 : Preferred Electronic Circuit

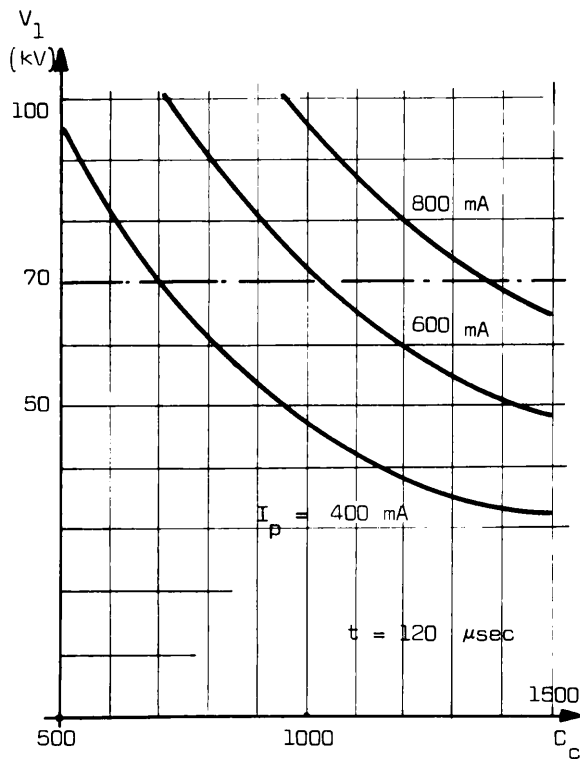

Fig. 9 : Necessary charging voltage V_1 with $V_{acc} = Cte$

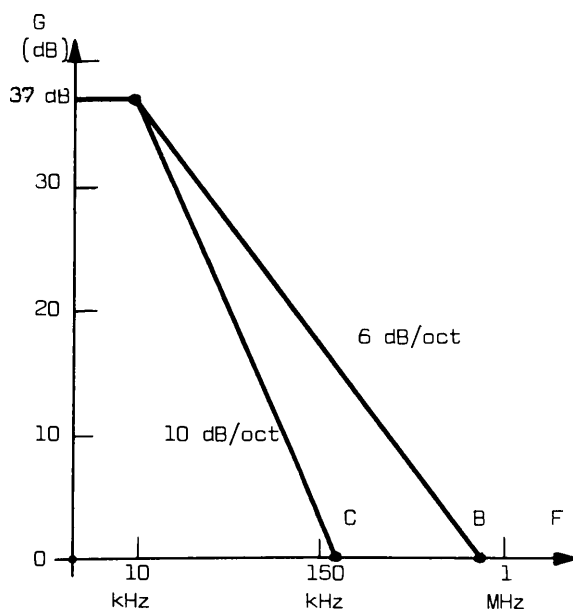
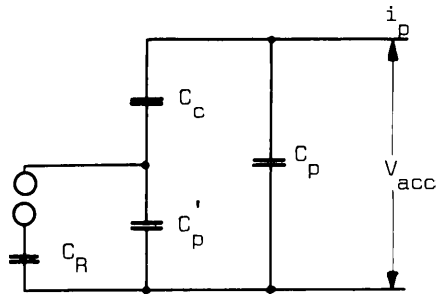

Fig. 11 : System Harmonic Response foreseen



$$C_p = 350 \text{ pF (Stray across acc. tube)}$$

$$C_c = 1000 \text{ pF}$$

$$C_p' = 200 \text{ pF (Stray at the cathode of EHT?)}$$

$$C_R = 50 \text{ nF}$$

$$t = 120 \text{ μsec}$$

Bouncer off :

$$1) \text{ E open : } C_{total} = C_p + \frac{C_c \cdot C_p'}{C_c + C_p'} \approx 510 \text{ pF}$$

$$2) \text{ E closed : } C_{total} = C_p + \frac{C_c (C_p' + C_R)}{C_c + C_p' + C_R} \approx 1350 \text{ pF}$$

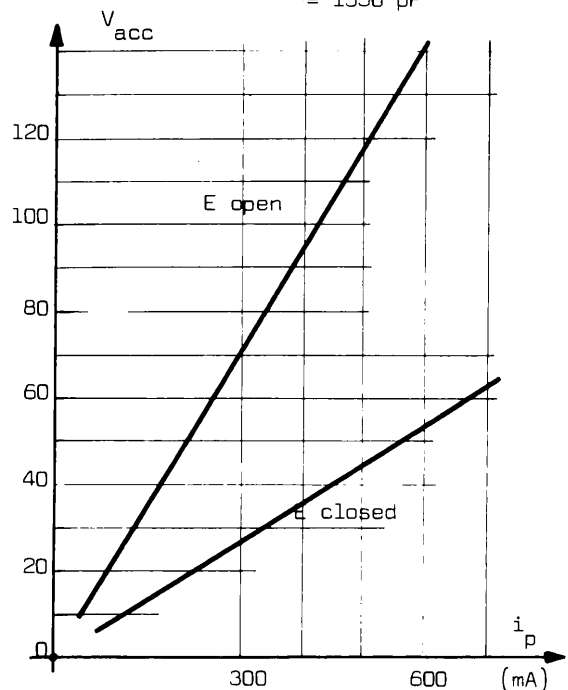

Fig. 10 : Voltage drop ΔV_{acc} as a function of acc. current (theoretical curve) (bouncer connected but "off")

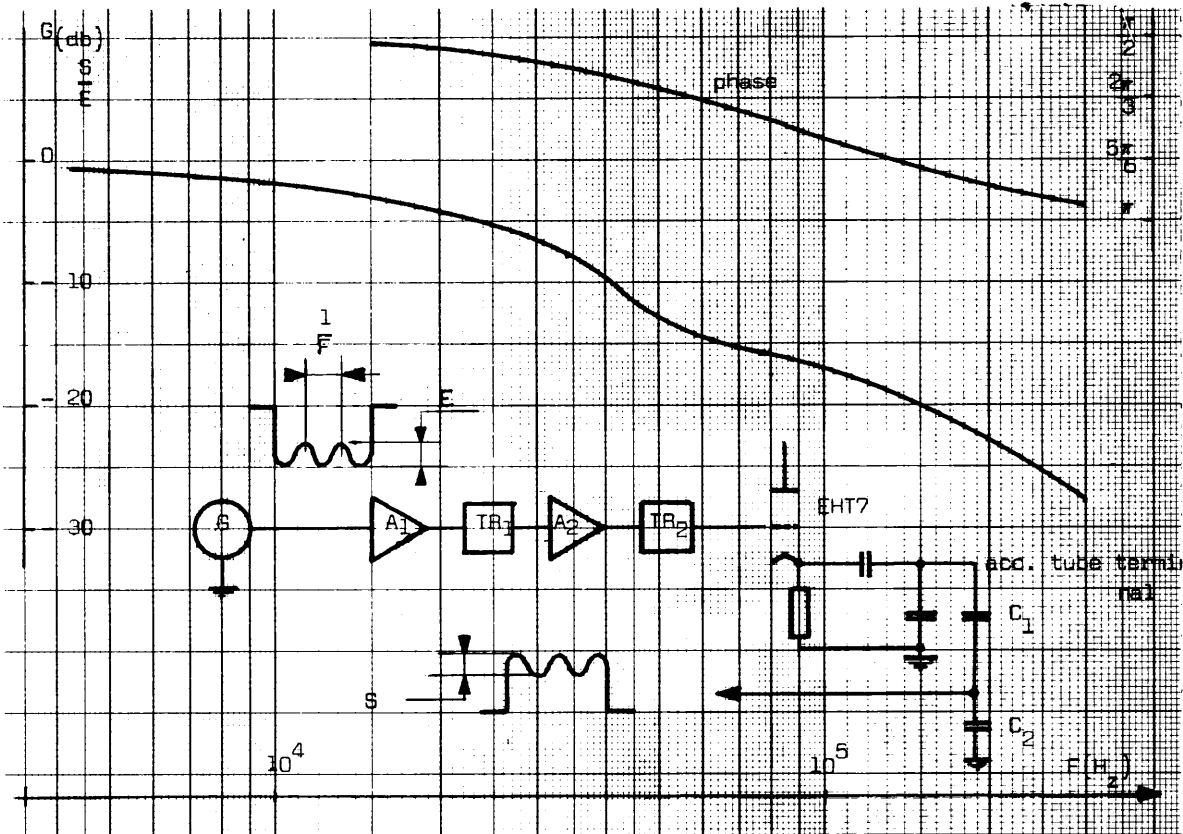

Fig. 12 : Bandwidth of open loop circuit

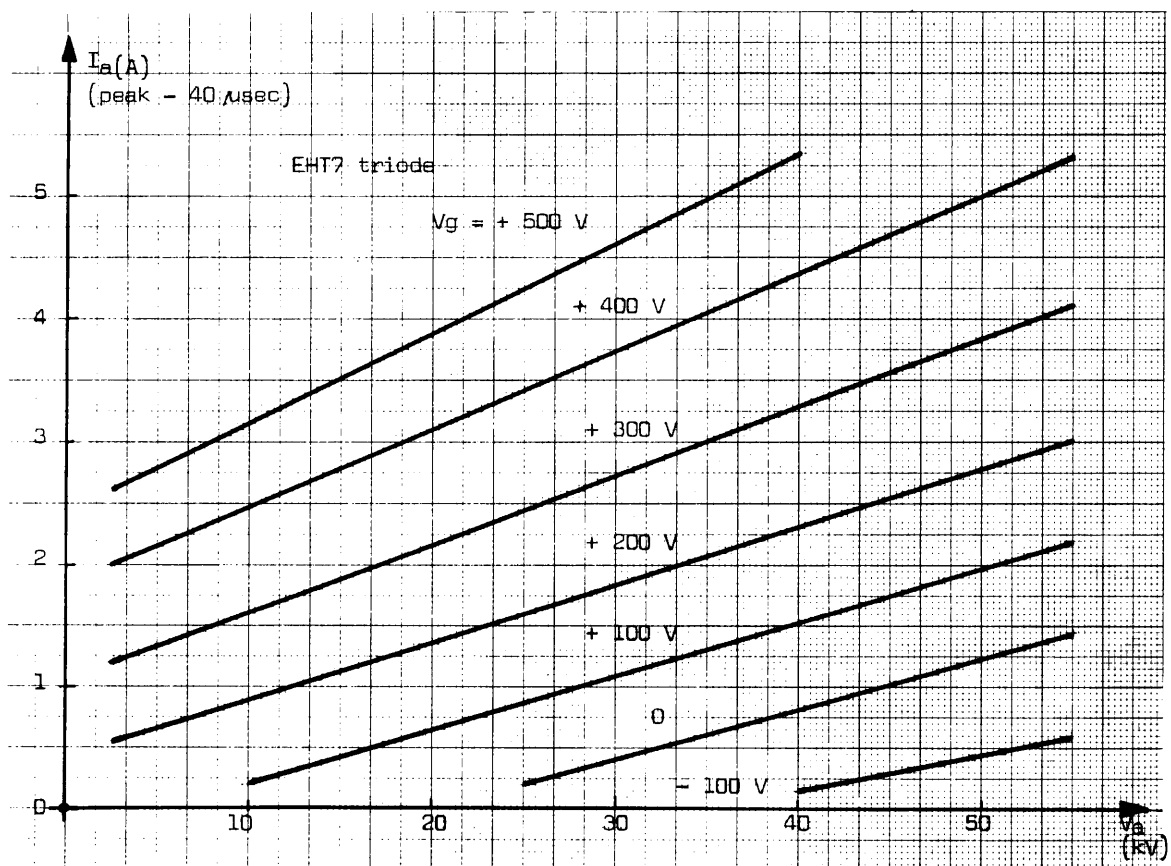

Fig. 13 : complementary curves of EHT7

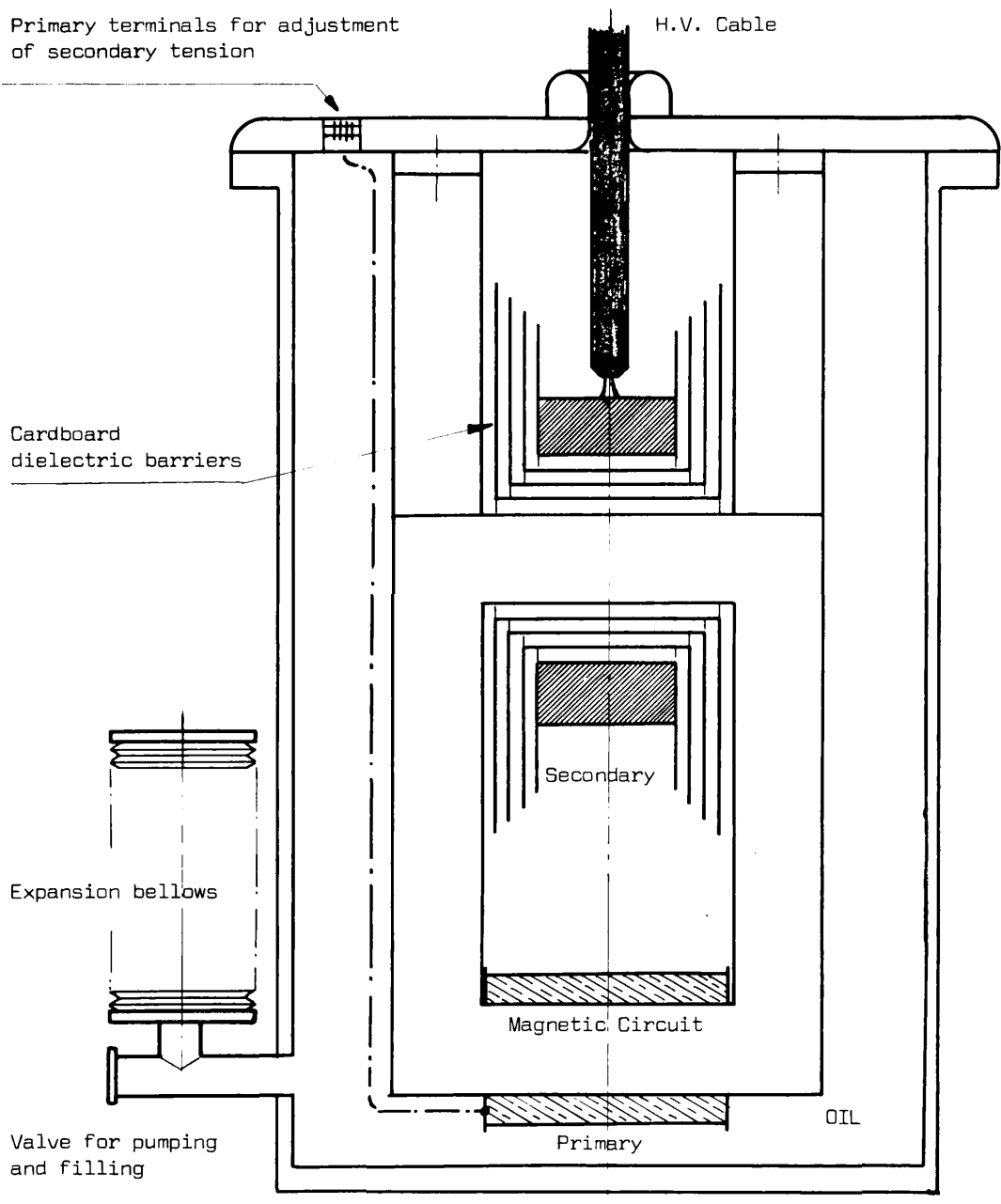

Fig. 14 : 220 V insulating transformer (TR4)

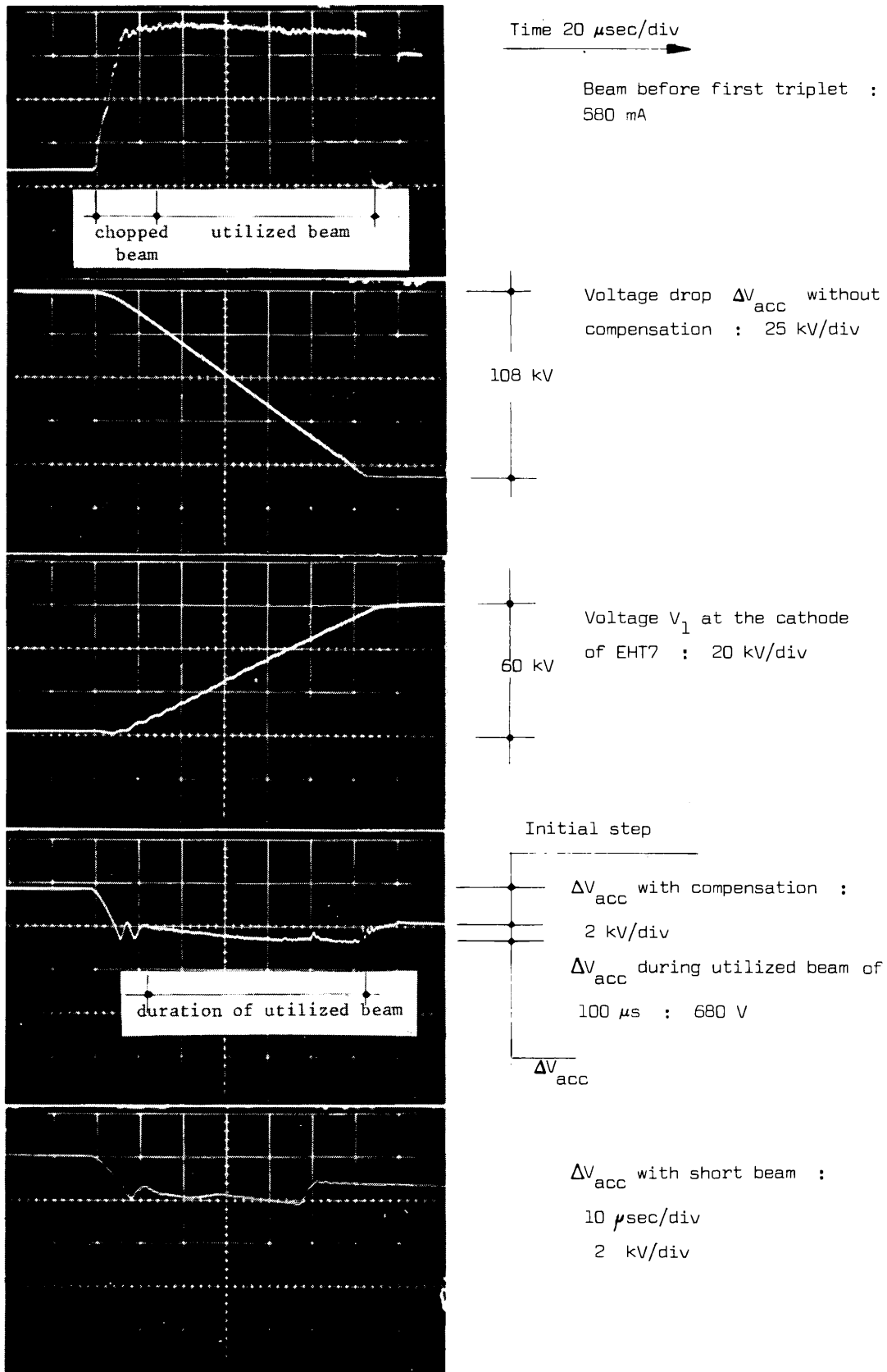

Fig 15 : oscillographs of beam and accelerating voltage

(3 MeV experimental Linac preinjector - $C_c = 1000 \text{ pF}$ - $C_p = 450 \text{ pF}$ - $C_p' = 350 \text{ pF}$)

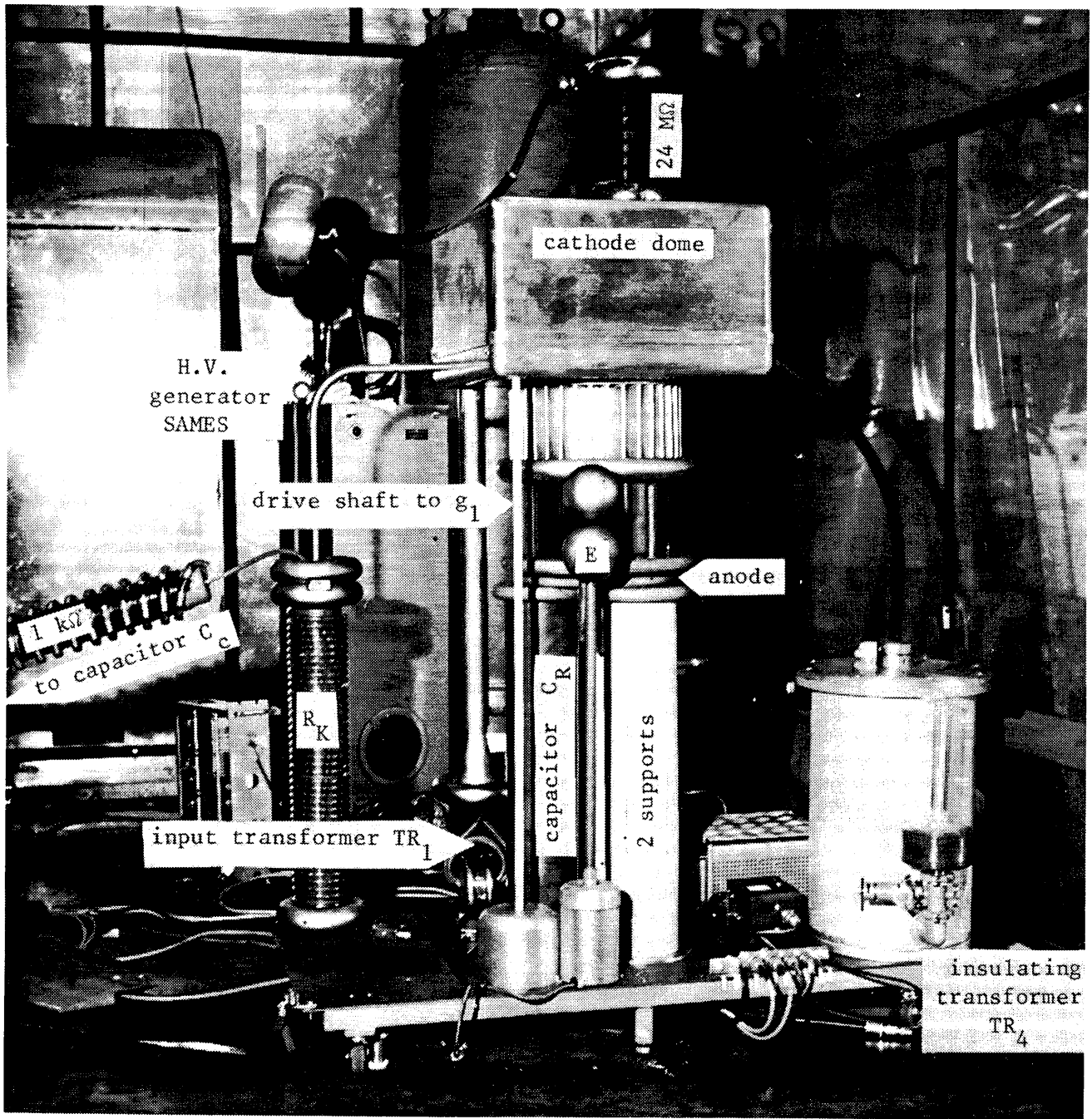

Fig. 16 : General view of bouncer