

CERN/PS 98-009 (LP)  
CLIC-Note-360

## CLIC, a 0.5 to 5 TeV $e^\pm$ Compact Linear Collider

Jean-Pierre Delahaye for the CLIC Study Team:

R. Bossart, H.H. Braun, G. Carron, F. Chautard, W. Coosemans, R. Corsini, E.D'Amico,  
M. Dehler, J.C. Godot, G. Guignard, J. Hagel, S. Hutchins, C.D. Johnson, E. Jensen, I. Kamber,  
A. Millich, P. Pearce, J.P. Potier, A.J. Riche, L. Rinolfi, D. Schulte, G. Suberlucq,  
L.Thorndahl, M. Valentini, D.J. Warner, I.Wilson, W.Wuensch, CERN,  
O.Napoly, CEA Saclay, T. Raubenheimer, R. Ruth, SLAC

### **Abstract**

The CLIC study of a high energy (0.5 - 5 TeV), high luminosity ( $10^{34}$  -  $10^{35}$  cm<sup>-2</sup> sec<sup>-1</sup>)  $e^\pm$  linear collider is presented. Beam acceleration using high frequency (30 GHz) normal-conducting structures operating at high accelerating fields (100 to 200 MV/m) significantly reduces the length and, in consequence the cost of the linac. Based on new beam and linac parameters derived from a recently developed set of general scaling laws for linear colliders, the beam stability is shown to be similar to lower frequency designs in spite of the strong wake-field dependency on frequency. A new cost effective and very efficient drive beam generation scheme for RF power production by the so-called "Two Beam Acceleration (TBA)" method is described. It uses a conventional thermionic gun and a fully-loaded normal-conducting linac operating at low frequency (937 MHz) to generate and accelerate the drive beam bunches and RF multiplication by funneling in compressor rings to produce the desired bunch structure. Recent 30 GHz hardware developments and results from the CLIC Test Facility (CTF) assessing the feasibility of the scheme are described.

Presented at the 6th European Particle Accelerator Conference, 22 - 26 June 1998,  
Stockholm, Sweden and at the XVII International Conference on High Energy  
Accelerators, 7 - 12 September, 1998, Dubna, Russia

# CLIC, a 0.5 to 5 TeV $e^\pm$ COMPACT LINEAR COLLIDER

Jean-Pierre Delahaye for the CLIC study team:

R. Bossart, H.H. Braun, G. Carron, F. Chautard, W. Coosemans, R. Corsini, E. D'Amico, M. Dehler, J.C. Godot, G. Guignard, J. Hagel, S. Hutchins, C.D. Johnson, E. Jensen, I. Kamber, A. Millich, P. Pearce, J.P. Potier, A.J. Riche, L. Rinolfi, D. Schulte, G. Suberlucq, L. Thorndahl, M. Valentini, D.J. Warner, I. Wilson, W. Wuensch, CERN, O. Napoly, CEA Saclay, T. Raubenheimer, R. Ruth, SLAC.

## ABSTRACT

The CLIC study of a high energy (0.5 - 5 TeV), high luminosity ( $10^{34}$  -  $10^{35}$   $\text{cm}^{-2} \text{sec}^{-1}$ )  $e^\pm$  linear collider is presented. Beam acceleration using high frequency (30 GHz) normal-conducting structures operating at high accelerating fields (100 to 200 MV/m) significantly reduces the length and, in consequence, the cost of the linac. Based on new beam and linac parameters derived from a recently developed set of general scaling laws for linear colliders, the beam stability is shown to be similar to lower frequency designs in spite of the strong wake-field dependency on frequency. A new cost-effective and efficient drive beam generation scheme for RF power production by the so-called "Two Beam Acceleration (TBA)" method is described. It uses a thermionic gun and a fully-loaded normal-conducting linac operating at low frequency (937 MHz) to generate and accelerate the drive beam bunches, and RF multiplication by funnelling in compressor rings to produce the desired bunch structure. Recent 30 GHz hardware developments and results from the CLIC Test Facility (CTF), assessing the feasibility of the scheme, are described.

## 1 INTRODUCTION

The Compact Linear Collider (CLIC) covers a centre-of-mass energy range for  $e^\pm$  collisions of 0.5 - 5 TeV [1] with a maximum energy well above those presently being proposed for any other linear collider [2]. It has been optimised for a 3 TeV  $e^\pm$  colliding beam energy to meet post-LHC physics requirements [3] but can be built in stages without major modifications. An overall layout of the complex is shown in Fig.1. In order to limit the overall length, high accelerating fields are mandatory and these can only be obtained with conventional structures by operating at a high frequency. The choice of 30 GHz is considered to be close to the limit beyond which standard technology for the fabrication of normal-conducting travelling-wave structures can no longer be used [4]. The RF power to feed the accelerating structures is extracted by transfer structures from high-intensity/low-energy drive beams running parallel to the main beam (Fig. 2). A single tunnel, housing both linacs and the various beam transfer lines without any modulators or klystrons, results in a very simple, cost effective and easily extendable arrangement (Fig. 3).

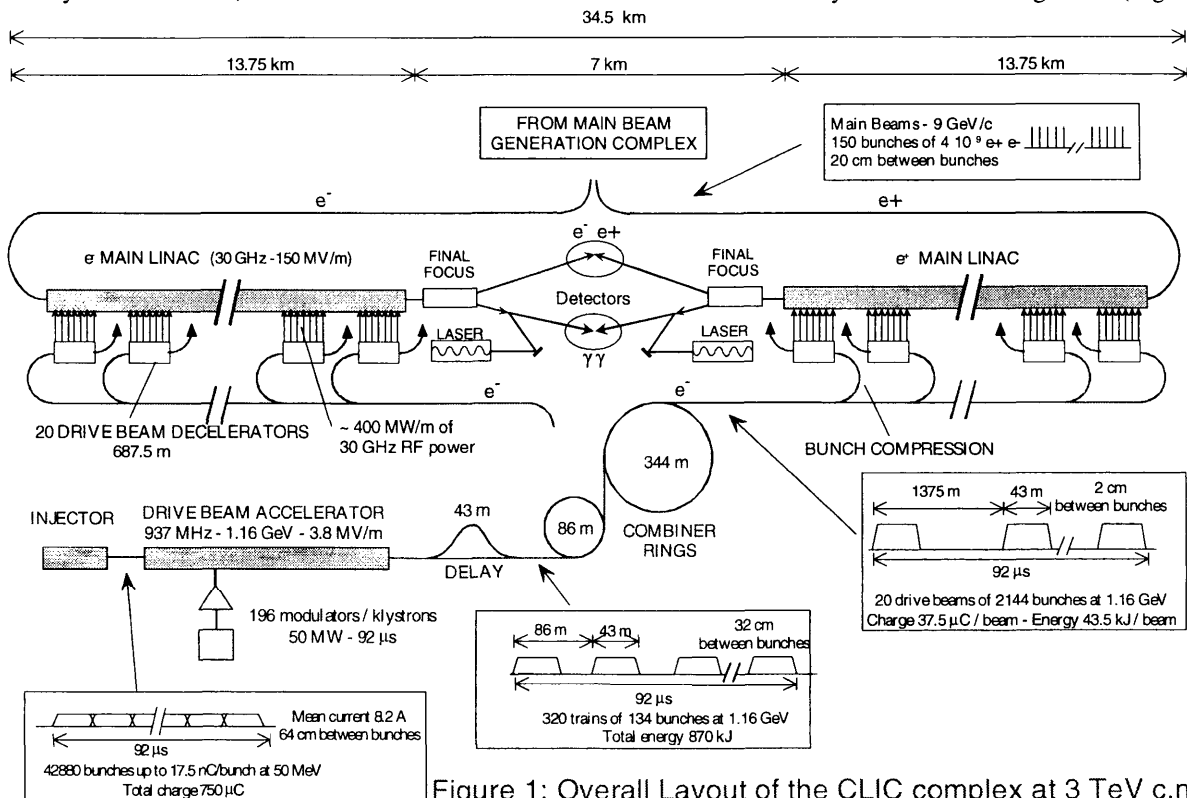

Figure 1: Overall Layout of the CLIC complex at 3 TeV c.m.

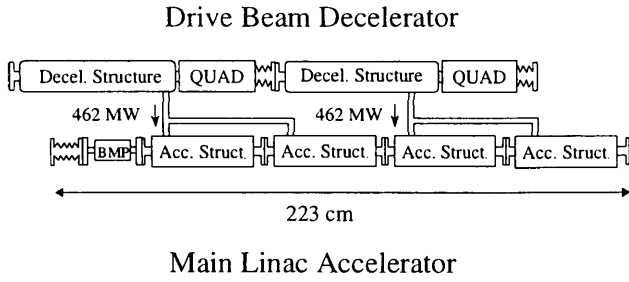

Figure 2: One main beam and drive beam module.

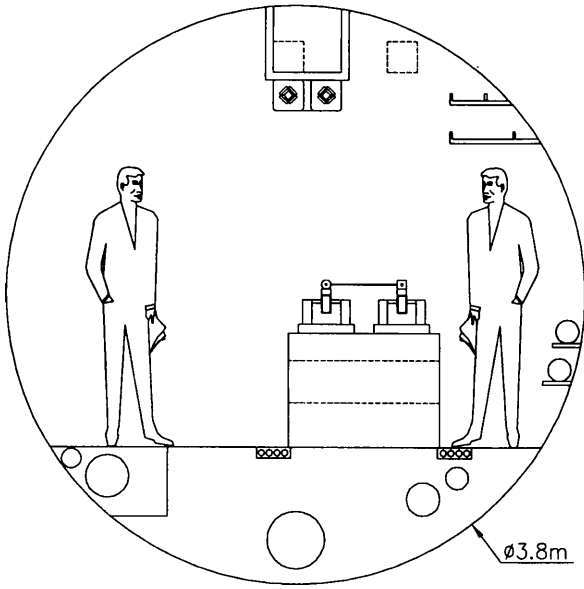

Figure 3: Tunnel cross-section.

## 2 MAIN PARAMETERS

The main beam and linac parameters are listed in Table 1 for various colliding beam energies. Following SLC experience, the luminosity at the Interaction Point (I.P.) has been reduced by 20 % to take into account a 25% dilution of the nominal beam sizes due to non-perfect beam alignment during collisions. The luminosity  $L$  normalised to the RF power,  $P_{RF}$ , depends on a small number of parameters in both low and high beamstrahlung regimes:

$$\frac{L_{Y \ll 1}}{P_{RF}} \propto \frac{\delta_B^{1/2} \eta_b^{RF}}{U_f \epsilon_{ny}^{*1/2}} \quad \text{and} \quad \frac{L_{Y \gg 1}}{P_{RF}} \propto \frac{\delta_B^{3/2} \eta_b^{RF}}{U_f^{1/2} \beta_y^{*1/2} \sigma_z^{1/2} \epsilon_{ny}^{*1/2}} \quad (1)$$

where  $\delta_b$ , is the mean energy loss,  $\eta_b^{RF}$  the RF to beam efficiency and  $U_f$ ,  $\sigma_z$ ,  $\beta_y$ ,  $\epsilon_{ny}^*$  the beam energy, bunch length, vertical beta function and vertical normalised beam emittance at the I.P respectively [5]. The parameters have been deduced from general scaling laws [5] covering more than a decade in frequency. These scaling laws, which agree with optimised linear collider designs, show that the beam blow-up during acceleration can be made independent of frequency for equivalent beam trajectory correction techniques. As a consequence

Table 1: Main beam and linac parameters

Beam param. at I.P.	0.5 TeV	1 TeV	3 TeV	5 TeV
Luminosity ( $10^{34} \text{ cm}^{-2} \text{ s}^{-1}$ )	0.5	1.1	10.6	14.9
Mean energy loss (%)	3.6	9.2	32	40
Photons /electrons	0.8	1.1	2.2	2.6
Rep. Rate (Hz)	200	150	75	50
$10^9 e^\pm$ / bunch	4	4	4	4
Bunches / pulse	150	150	150	150
Bunch spacing (cm)	20	20	20	20
H/V $\epsilon_n$ ( $10^{-8} \text{ rad.m}$ )	188/10	148/7	60/1	58/1
Beam size (H/V) (nm)	196/4.5	123/2.7	40/0.6	27/0.45
Bunch length ( $\mu\text{m}$ )	50	50	30	25
Accel.gradient (MV/m)	100	100	150	200
Two linac length (km)	7	14	27.5	35
Accelerating Sections	10802	21604	43736	54802
Power / section (MW)	116	116	231	386
RF to beam eff. (%)	35.5	35.5	26.6	19.4
AC to beam eff. (%)	14.2	14.2	10.6	7.8
AC power (MW)	68	102	206	310

and in spite of the strong dependence of wakefields on frequency, CLIC whilst operating at a high frequency but with a low charge per bunch  $N$ , a short bunch length  $\sigma_z$ , a strong focussing optics and a high accelerating gradient  $G$ , preserves the vertical emittance as well as low frequency linacs. The RF to beam transfer efficiency is optimised by using a large number of bunches and by choosing an optimum accelerating section length. In spite of the reduced charge per bunch and the high gradient, excellent RF to beam efficiency is obtained because the time between bunches is shorter and the shunt impedance of the accelerating structures is higher.

Up to 1 TeV, where the beamstrahlung parameter  $Y < 1$ , the beam parameters are chosen to have a small  $\delta_b$ . To limit the power consumption above 1 TeV,  $\epsilon_{ny}$  is reduced and  $Y$  allowed to be  $\gg 1$ . In this regime (see Eq.1) high frequency linacs are very favourable because  $\sigma_z$  is small. As a consequence, even with  $Y \gg 1$ , neither the  $L$  spectrum (Fig. 4), nor the number of emitted gammas which increase the background in the detector, significantly deteriorate with energy [1] (see Table 1).

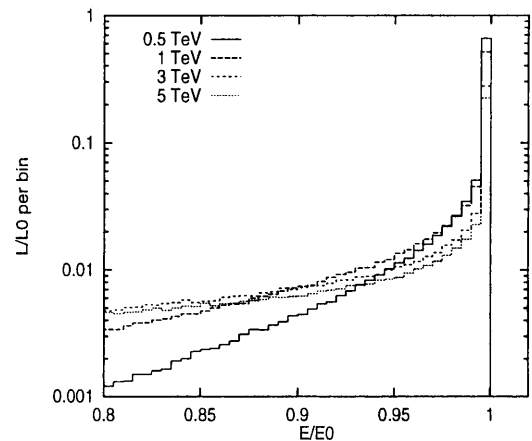

Figure 4: Luminosity distribution with energy.

### 3 MAIN LINAC

The effects of the strong 30 GHz wakefields ( $W_T$ ) can be kept moderate by choosing  $N$  to be small ( $4 \cdot 10^9$  at all energies) and  $\sigma_z$  at the lower limit that results from the momentum spread acceptance of the final focus. With a high gradient  $G$  and strong focusing, the single bunch blow-up  $\Delta\epsilon_{ny}$  at all energies can be kept below  $\approx 100\%$  (Fig. 5) [6]. To obtain the values of  $L$  given in Table 1 requires a gradual reduction in the injected  $\epsilon_{ny}$  from  $5 \cdot 10^{-8}$  rad.m at 0.5 TeV to  $0.5 \cdot 10^{-8}$  rad.m at 5 TeV. Limiting the overall  $\Delta\epsilon_{ny}$  relies in part on the use of bumps which are created locally at 5-10 positions along the linac by mis-aligning a few upstream cavities. The effects of these bumps are used to minimise the local  $\epsilon_{ny}$  (Fig. 5). Without these bumps, dispersive effects are  $\approx 10$  times weaker than  $W_T$  effects. The average lattice  $\beta$ -function starts from  $\approx 4$ -5 m and is scaled approx. as (energy) $^{0.5}$ . The FODO lattice is made up of sectors with equi-spaced quadrupoles of the same length and normalised strength, with matching insertions between sectors. The RF cavities and quadrupoles are pre-aligned to 10 and 50  $\mu\text{m}$  respectively using a stretched-wire positioning system. The off-set misalignments of the beam position monitors (BPMs) are measured as follows. A section of 12 quadrupoles is switched off, and with the beam centred in the two end BPMs of this section, the relative mis-alignment of the other monitors are measured with an accuracy of 0.1  $\mu\text{m}$ . The beam trajectory and ground motion effects are corrected by a 1-to-1 correction. BNS damping is achieved by running off-crest of the RF-wave by  $6^\circ$  to  $10^\circ$ . Multiple bunches are required to obtain high luminosities. The multi-bunch  $\Delta\epsilon_{ny}$  is  $\approx 20\%$ . To make the 150-bunch train stable requires a strong reduction of  $W_T$  [7]. Each cell of the 150-cell structure [8] is damped by its own set of four radial waveguides (Fig. 6) giving a  $Q$  of 16 for the lowest dipole mode. A simple linear taper of the iris dimension provides a de-tuning frequency spread of 2 GHz (5.4%). Calculations of the transverse wakefields in this structure with non-perfect loads indicate a short-range level of about 1000 V/(pC-mm-m) decreasing to less than 1 % at the second bunch and with a long time level below 0.1 %.

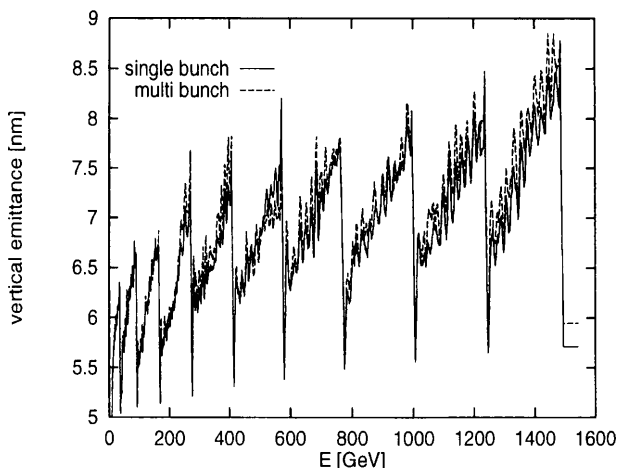

Figure 5: Emittance variation along the main linac.

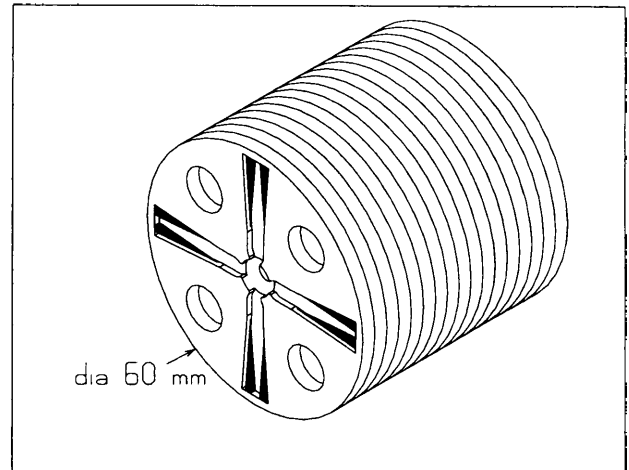

Figure 6: 30 GHz Tapered Damped Structure.

### 4 THE RF POWER SOURCE

The RF power for each 687.5 m section of the main linac is provided by a secondary low-energy high-intensity electron beam which runs parallel to the main linac. The power is generated by passing this electron beam through energy-extracting RF structures (transfer structures) in the so-called "Drive Beam Decelerator". For the 3 TeV c.m. collider there are 40 drive beams (20 per linac). Each drive beam has an energy of 1.16 GeV and consists of 2144 bunches with a spacing of 2 cm and a maximum charge per bunch of 17.5 nC. These 20 drive beams, spaced at intervals of 1.375 km, are produced as one long pulse by one of the two drive beam generators. By sending this drive beam train towards the on-coming main beam, different time slices of the pulse can be used to power separate sections of the main linac (see Fig. 1). This drive beam is generated as follows [9]. All the bunches (for 20 drive beams) are first generated and accelerated with a spacing of 64 cm as one long continuous train in a normal-conducting fully-loaded 937 MHz linac operating at a gradient of 3.8 MV/m (Fig.1). This 8.2 A 92  $\mu\text{s}$  continuous beam can be accelerated with an RF/beam efficiency  $\approx 97\%$ . After acceleration the continuous train of 42880 bunches is split up into 320 trains of 134 bunches using the combined action of a delay line and a grouping of bunches in odd and even RF buckets. These trains are then combined in a 86 m circumference ring by interleaving four successive bunch trains over four turns to obtain a distance between bunches at this stage of 8 cm. A second combination using the same mechanism is subsequently made in a similar, larger 344 m circumference ring, yielding a final distance between bunches of 2 cm. The energy-extracting transfer structures consist of 4 periodically-loaded rectangular waveguides coupled to a circular beam pipe. Each 80 cm long structure provides 462 MW of 30 GHz RF power, enough to feed two accelerating structures. For stability in the drive beam decelerator, these structures have also to be damped to reduce long-range transverse wakefield effects.

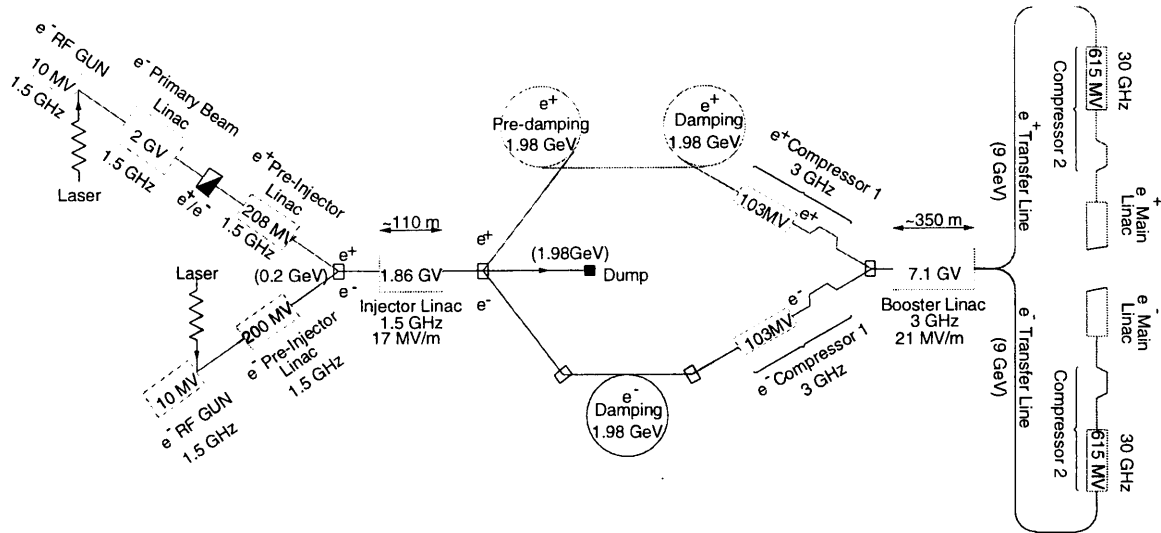

Figure 7: Layout of the injector complex of the main beams.

## 5 INJECTOR OF MAIN BEAMS

The layout of the centrally-located injector complex of the main beams [10] is shown in Fig.7. To reduce costs the same linacs accelerate both electrons and positrons on consecutive RF pulses. The positrons are produced by standard technology already in use at the SLC but with improved performance due to the larger acceptance of the L-band capture linac. Both the electron and positron beams are damped transversely in specially designed damping rings for low emittances [11]. The damping rings are made up of arcs based on a Theoretical Minimum Emittance (TME) lattice and straight sections equipped with wigglers. The positrons are pre-damped in a pre-damping ring. The generation of extremely low emittances ( $5 \cdot 10^{-7}$  and  $5 \cdot 10^{-9}$  rad.m. in the horizontal and vertical planes respectively), required for the 3 and 5 TeV CLIC designs, is still under study and may require additional wigglers or another damping ring. The bunches are compressed in two stages in magnetic chicanes [12], the first one after the damping ring using 3 GHz structures, the second one just before injection into the main linac with 30 GHz structures.

## 6 THE BEAM DELIVERY

A new multi-bunch Final Focus (FF) design for the 0.5 TeV machine has recently been studied [13]. It is based on a crossing angle of 5 mrad and can be run with, or without crab-crossing cavities if a 20% reduction in luminosity can be accepted. The last quadrupole is split into a 48 mm large-bore SC one and a smaller 13.7 mm normal-conducting one. The outgoing beam is deflected by the first quadrupole into the field-free region of the second. The free distance between quadrupoles is 3 m,  $\beta_y$  is chosen to be 0.1 mm to avoid the Oide synchrotron radiation limit in the final magnets and to prevent high chromaticity. Using this doublet, the final telescope has a de-magnification of  $12 \times 30$ . The momentum acceptance of the FF system is  $\approx 1\%$ . The possible use of this system at higher energies requires further study. Scaling the FF length (including the chromaticity correction section which has two pairs of sextupoles) with  $\gamma^{0.5}$ , gives  $\approx 0.8$  km at 1 TeV and 1.4 km at 3 TeV. The collimation section has not yet been studied however scaling the JLC design gives  $\approx 2$  km at 3 TeV, resulting in a total  $\approx 7$  km for the whole beam delivery system.

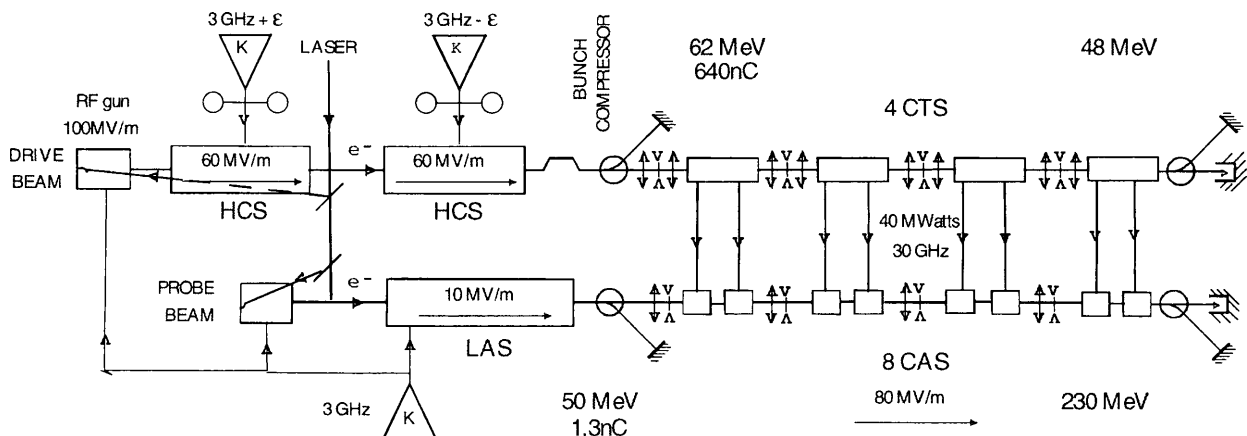

Fig. 8: Demonstration of the Two Beam Acceleration in the CLIC Test Facility

## 7 TEST FACILITIES

The first CLIC Test Facility (CTF1) operated from 1990 to 1995 and demonstrated the feasibility of two-beam power generation. It produced 76 MW of 30 GHz RF power from a low-energy high-intensity beam and generated on-axis gradients in the 30 GHz structures of 125 MV/m. A new test facility (CTF2) [14] is at present being commissioned (see Fig.8). The 30 GHz part of this facility is equipped with a few-microns precision active-alignment system. The 48-bunch 640 nC drive beam train is generated by a laser-driven S-band RF gun with a Cs<sub>2</sub>Te photocathode (PC). It is accelerated to 62 MeV by two travelling-wave sections (HCS) operating at two slightly different frequencies to provide beam loading compensation along the train. After passing through a magnetic bunch compressor, the bunch train passes through four transfer structures (CTS), each producing enough power to drive two 30 GHz accelerating sections (CAS) with 40 MW, 12 ns long pulses. The two bunches of the probe beam are generated by an RF gun with a CsI+Ge PC. They are pre-accelerated to 50 MeV at S-band before being injected into the 30 GHz accelerating linac. Only half of the two-beam linac has been installed, completion is planned for March 1999. The drive beam RF gun has produced a single bunch charge of 50 nC and a maximum charge of 450 nC in 48 bunches. Although the power levels are not yet up to nominal values, a series of cross-checks between drive beam charge, generated RF power, and main beam energy gain have shown excellent agreement. 36 MW have been produced so far by the two transfer structures using a train of 48 bunches of 375 nC total charge. This resulted in a 23 MeV energy gain of the 0.7 nC probe beam. The highest accelerating gradient obtained so far is 50 MV/m.

A new facility (CTF3) is under study (see Fig.9), which would test all major parts of the CLIC RF power generation and acceleration scheme. To reduce costs, it is based on the use of 3 GHz klystrons and modulators from the LEP injector Linac (LIL). The drive beam is generated by a thermionic gun and is accelerated by eight  $\approx 1$  m long fully-loaded 3 GHz structures operating at 12 MV/m with an RF to beam efficiency of 96%. The power is supplied by eight 40 MW klystrons and compressed by a factor 2.5 to give a peak power at each structure of 100 MW. The beam pulse is 1.1  $\mu$ s long with an average current of 8.2 A. The bunches are initially spaced by 20 cm (two 3 GHz buckets) but after two stages of frequency multiplication (the first times-2 in a combiner delay, the second times-5 in a combiner ring) they have a final spacing of 2 cm. This bunch train with a maximum charge of 5.5 nC per bunch is then decelerated by seven 0.8 m long transfer structures in the 30 GHz drive beam decelerator from an initial energy of 100 MeV to a final energy of 56 MeV. Each transfer structure provides 512 MW. The main beam is accelerated to 1.0 GeV by fourteen 30 GHz accelerating structures operating at a gradient of 150 MV/m.

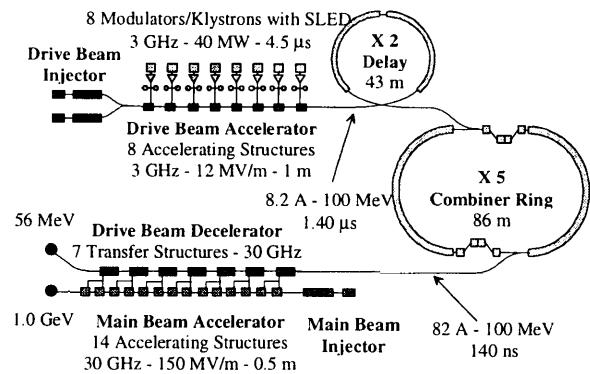

Figure 9: CTF3 schematic layout.

## 8 CONCLUSION

The CLIC Two-Beam scheme is an ideal candidate for extending the energy reach of a future high-luminosity linear collider from 0.5 TeV up to 5 TeV c.m. The high operating frequency (30 GHz) allows the use of high accelerating gradients (100-200 MV/m) which shorten the linacs (27.5 km for 3 TeV) and reduce the cost. The effects of the high transverse wakefields have been compensated by a judicious choice of bunch length, charge and focusing strength such that the emittance blow-up is made independent of frequency for equivalent beam trajectory correction techniques. The two-beam RF power source based on a fully-loaded normal-conducting low-frequency linac and frequency multiplication in combiner rings is an efficient, cost effective and flexible way of producing 30 GHz power. The feasibility of Two-Beam power production has been demonstrated in the CLIC Test Facilities (CTF1 and CTF2). A third test facility is being studied to demonstrate the newly-proposed drive beam generation and frequency multiplication schemes.

## REFERENCES

- [1] J.P.Delahaye and 6 co-authors, Proc. PAC'97, Vancouver, B.C., Canada, and CERN/PS 97-23, 1997.
- [2] Int. Linear Collider Technical Review Committee Report, ed. G.Loew, SLAC-R-95-471, 1995.
- [3] J.Ellis, E.Keil, G.Rolandi, CERN-EP/98-03, 1998.
- [4] W.Schnell, CERN-LEP-RF/86-06, 1986.
- [5] J.P.Delahaye and 3 co-authors, CERN/PS/97-51, 1997.
- [6] D.Schulte, this conference and CLIC Note 356, 1998.
- [7] G. Guignard, J. Hagel, CLIC Note 348 and Proc. PAC'97, Vancouver, B.C., Canada, 1997.
- [8] M.Dehler, CLIC note 358, 1998; M. Dehler and 5 co-authors, Proc. PAC'97, Vancouver, B.C., Canada, 1997.
- [9] R.Corsini and 10 co-authors, this conference.
- [10] L.Rinolfi, CLIC note 354, 1997.
- [11] J.P.Potier, L.Rivkin, CLIC note 337 and Proc. PAC'97, Vancouver, B.C., Canada, 1997.
- [12] E.D'Amico and 2 co-authors, this conference and CLIC note 355, 1998.
- [13] O.Napoly, CEA/DAPNIA/SEA-97-17, 1997.
- [14] The CLIC study group, CERN/PS 96-14, 1996.