

CERN/PS/BR 80-6
25 March 1980

A FREQUENCY-SELECTIVE SELF-BALANCING BRIDGE

An application to closed-orbit signal suppression

C.F. Christiansen^{*)} and G. Gelato

^{*)} Visitor from La Plata University, Argentina.

CONTENTS

	<u>Page</u>
1. INTRODUCTION AND SUMMARY	1
2. PRINCIPLE OF OPERATION	1
3. THE FET ATTENUATOR	2
4. CLOSED-LOOP OPERATION	7
5. CLOSED-ORBIT SIGNAL SUPPRESSOR	10
ACKNOWLEDGEMENTS	12
REFERENCES	12

1. INTRODUCTION AND SUMMARY

The circuit discussed in this report was developed with a view to using it for the suppression of the closed-orbit component of the beam position signal in the PSB transverse feedback system. In the course of its development, different solutions to the problem were considered and carefully analysed.

The analysis of the solution finally adopted is presented here, as the authors feel that it can be of interest to the designer faced with the more general problem of eliminating from a modulated signal any selected portion of its spectrum (symmetrical around the carrier), leaving the rest unchanged.

In the course of the analysis, one encounters differential equations with time-varying coefficients; they can be reduced to integral equations of a type which lends itself to a rapidly convergent iterative solution of the Volterra type. This fact makes it possible to write the results of the analysis in a form which can be easily interpreted, and from which design criteria can be derived and the expected performances readily estimated.

2. PRINCIPLE OF OPERATION

Consider the bridge shown in Fig. 1. In addition to the effect of parameter variations, a bridge will also be sensitive to variations of the voltages feeding its arms. Nevertheless, it does not make sense to talk about an equilibrium condition unless the two voltage sources are coherent.

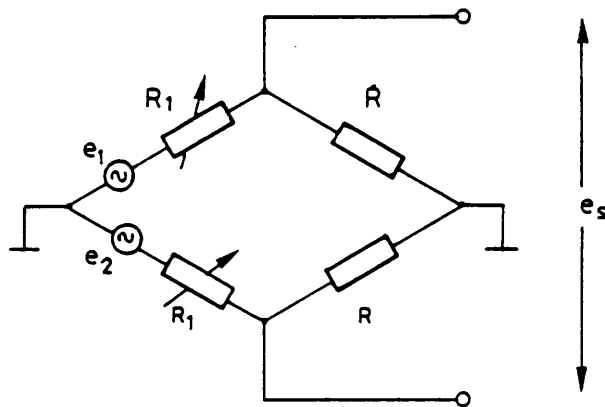

Fig. 1

In the following sections the equilibrium of the bridge will be studied when the arms are fed by two amplitude-modulated in-phase carriers, the modulating envelope being a sum of two periodic but arbitrary time functions, $h(t)$ and $g(t)$, with non-overlapping frequency spectra. Each carrier is modulated by the same amplitude functions, but with opposing phases:

$$e_1(t) = [1 + h(t) + g(t)]f(t)$$

$$e_2(t) = [1 - h(t) - g(t)]f(t) .$$

In order to get a self-balancing action, a circuit as indicated in Fig. 2 is used. The error signal is measured and detected synchronously, making the product of the sum and difference of the input signals in an analog multiplier. One of the modulating envelopes is selected by a low-pass filter and fed back to the FETs in order to achieve the balance condition. This produces a zero for the carrier with the selected envelope, but the other modulated component will be only slightly affected.

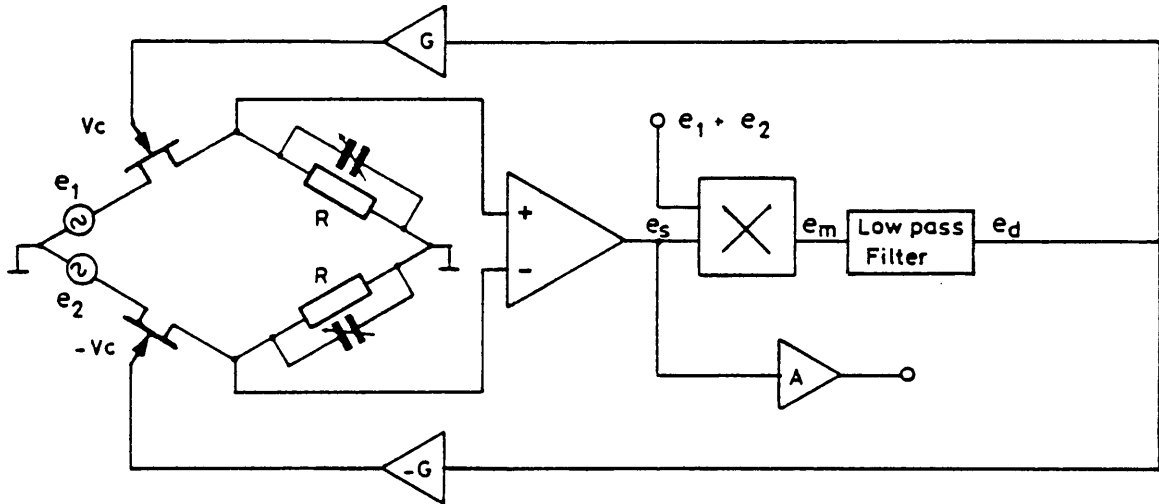

Fig. 2

The product of the synchronously detected envelope and the input voltages is made in the FETs, the error signal at the output of the differential amplifier being

$$e_s(t) = e_1(t)[1 - h(t)] - e_2(t)[1 + h(t)] ,$$

from which

$$e_s(t) = 2g(t)f(t) .$$

The frequency spectra of the various signals is shown in Fig. 3, where it can be observed that the bridge acts as a filter on the modulated carrier and its sidebands, the rejection bandwidth being determined by the low-pass filter following the analog multiplier.

3. THE FET ATTENUATOR

The analysis of the variable branches of the bridge reduces to that of a remote-controlled attenuator, shown in Fig. 4, with a FET acting as a variable resistance. Owing to the presence of the shunt capacitance and the variable resistance of the FET, a set of linear differential equations with time-varying coefficients occur, when the equivalent circuit of Fig. 4b is analysed. In this section a first-order approximation to the solution will be studied.

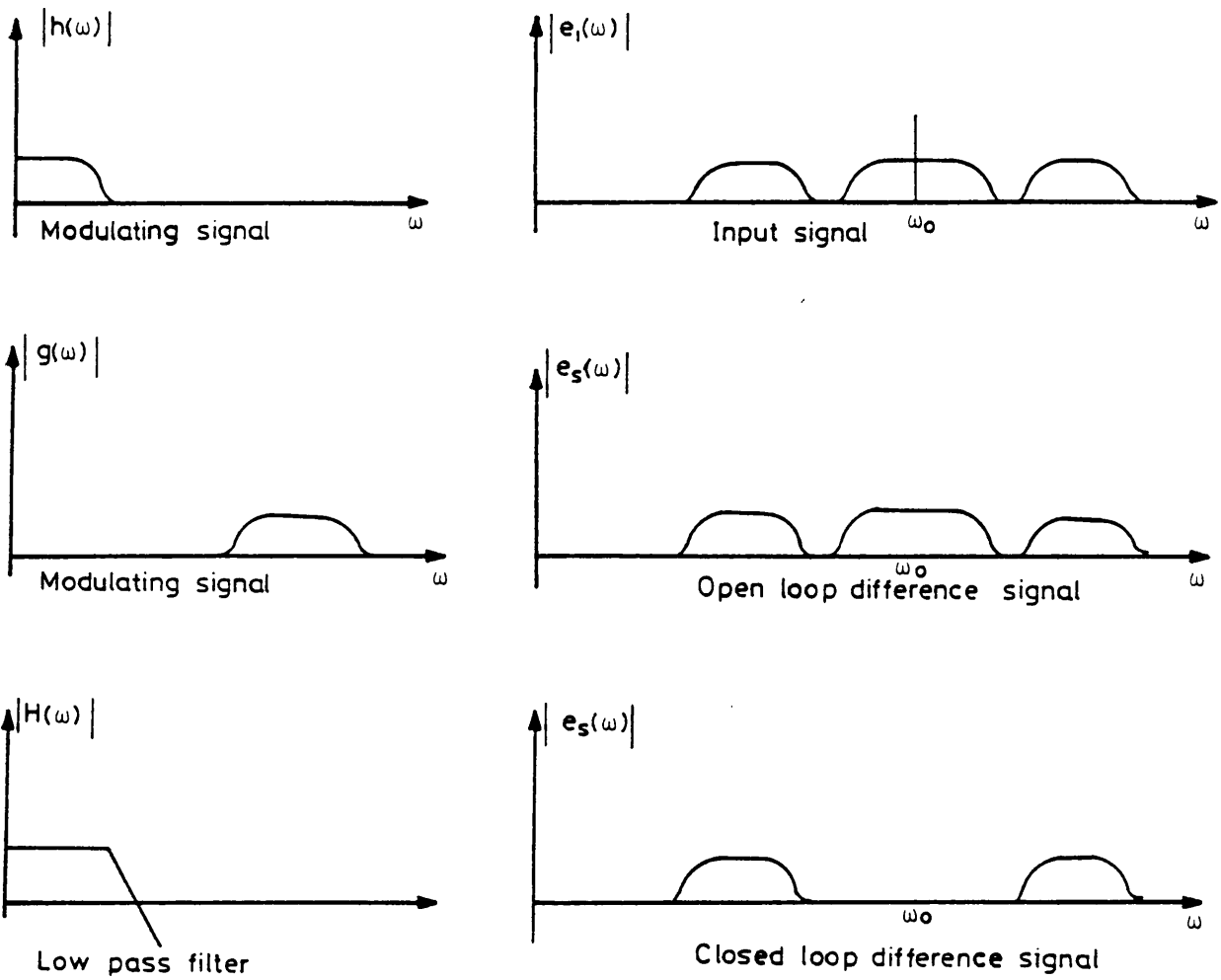

Fig. 3

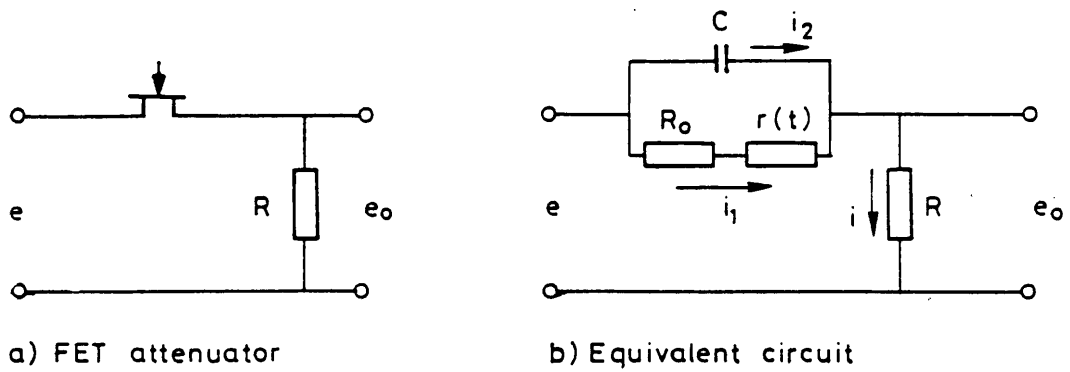

Fig. 4

The following equations may be used to describe the potential balances in the circuit:

$$e(t) = i_1(t)[R_1(t) + R] + i_2(t)R \quad (1)$$

$$i_1(t)R_1(t) = \frac{1}{C} \int_0^t i_2(t) dt . \quad (2)$$

Let

$$R_1(t) = R_0 + r(t) \quad (3)$$

and

$$i(t) = i_1(t) + i_2(t) . \quad (4)$$

Equation (1) is a linear differential equation with a time-varying coefficient. In order to transform it into an integral equation, let the following Laplace transforms be introduced

$$\begin{aligned} \mathcal{L}e(t) &= E(s) \\ \mathcal{L}i(t) &= I(s) \end{aligned} \quad (5)$$

$$\mathcal{L}i_1(t)r(t) = G(s) .$$

Assuming zero initial conditions, the Laplace transform of Eq. (1) is given by

$$E(s) = I_1(s)[R_0 + R] + I_2(s)R + G(s) \quad (6)$$

and the Laplace transform of Eq. (2) becomes

$$I_1(s)R_0 + G(s) = \frac{1}{sC} I_2(s) \quad (7)$$

If Eq. (7) is introduced into Eq. (6), we obtain

$$E(s) = I_1(s)[R + R_0][1 + sT_p] + G(s)[1 + sT] . \quad (8)$$

For simplicity we have introduced the notation

$$T_p = \frac{1}{\omega_p} = \frac{C R R_0}{R + R_0}$$

$$T = \frac{1}{\omega_z} = C R$$

$$Y_1(s) = \frac{1}{[R + R_0][1 + sT_p]}$$

$$Y_2(s) = \frac{1 + sT}{[R + R_0][1 + sT_p]} .$$

With this notation we can write the expression for $I_1(s)$ in the following form:

$$I_1(s) = E(s)Y_1(s) - G(s)Y_2(s) . \quad (9)$$

Let the inverse transforms of $Y_1(s)$ and $Y_2(s)$ be $y_1(t)$ and $y_2(t)$, respectively. Then by applying the convolution theorem to Eq. (9), we obtain

$$i_1(t) = \int_0^t y_1(t-u)e(u) du - \int_0^t y_2(t-u)r(u)i_1(u) du . \quad (10)$$

Placing the variable part of the resistor equal to zero, the current through it becomes

$$i_{10}(t) = \int_0^t y_1(t-u)e(u) du . \quad (11)$$

Equation (10) can now be written as a Volterra-type integral equation¹⁾:

$$i_1(t) = i_{10}(t) - \int_0^t y_2(t-u)r(u)i_1(u) du . \quad (12)$$

The solution given by Volterra is a series of functions

$$i_1(t) = i_{10}(t) - i_{11}(t) + i_{12}(t) - i_{13}(t) + \dots , \quad (13)$$

the general term being

$$i_{1(n+1)}(t) = \int_0^t y_2(t-u)r(u)i_{1n}(u) du , \quad n = 0, 1, 2, \dots . \quad (14)$$

The series of Eq. (13) is rapidly convergent for small deviations of $r(t)$, and approximates to

$$i_1(t) \cong i_{10}(t) - i_{11}(t) . \quad (15)$$

The inverse transforms of $Y_1(s)$ and $Y_2(s)$ are

$$y_1(t) = \frac{1}{TR_0} \exp(-\omega_p t) , \quad (16)$$

$$y_2(t) = \frac{1}{R_0} \left[\delta(t) + (\omega_z - \omega_p) \exp(-\omega_p t) \right] ; \quad (17)$$

The term $i_{10}(t)$ can now be evaluated introducing $y_1(t)$ into Eq. (11):

$$i_{10}(t) = \frac{1}{TR_0} \int_0^t e(u) \exp \left[-\omega_p(t-u) \right] du . \quad (18)$$

Owing to the properties of Eqs. (19) and (20),

$$\mathcal{L} \left[\int_0^t x(u)z(t-u) du \right] = X(s)Z(s) \quad (19)$$

and

$$\frac{1}{1 + sT_p} = 1 - sT_p , \quad (20)$$

valid for small values of T_p ,

$$i_{10}(t) = \frac{1}{R + R_0} \mathcal{L}^{-1} \left[E(s)(1 - sT_p) \right] , \quad (21)$$

which becomes

$$i_{10}(t) = \frac{1}{R + R_0} \left[e(t) - T_p \frac{d}{dt} [e(t)] \right] . \quad (22)$$

Introducing Eqs. (17) and (22) into Eq. (14), for $n = 0$ we obtain the first-order approximation term for the current through the resistor R_1 :

$$\begin{aligned} i_{11}(t) = \frac{1}{R_0[R + R_0]} & \left\{ \int_0^t \delta(t-u)e(u)r(u) du + \right. \\ & - \int_0^t \delta(t-u)T_p \frac{d}{dt} [e(u)]r(u) du + \\ & \left. + (\omega_z - \omega_p) \int_0^t \exp \left[-\omega_p(t-u) \right] r(u) \left[e(u) - T_p \frac{d}{dt} [e(u)] \right] du \right\} . \quad (23) \end{aligned}$$

It is now a simple matter to solve the preceding integrals and obtain

$$\begin{aligned} i_{11}(t) = \frac{1}{R_0} & \left[\left(\rho + \frac{R}{R + R_0} \rho' T_p \right) (e - T_p e') + \right. \\ & \left. - \frac{R}{R + R_0} \rho (e - 2T_p e + T_p^2 e'') \right] , \quad (24) \end{aligned}$$

where for simplicity we have introduced the following notation:

$$\rho = \frac{r(t)}{R + R_0}, \quad \rho' = \frac{1}{R + R_0} \frac{d}{dt} [r(t)];$$

$$e = e(t), \quad e' = \frac{d}{dt} [e(t)], \quad e'' = \frac{d^2}{dt^2} [e(t)].$$

Returning to Eq. (15), we can introduce Eqs. (22) and (24) to obtain the total current through the resistive part of the FET:

$$i_1(t) = \frac{1}{R + R_0} \left[e - T_p e' - \rho e + \left(1 - \frac{R}{R_0} \right) T_p \rho e' + \right. \\ \left. - \frac{R}{R_0} T_p \rho' e + \frac{R}{R_0} \rho T_p^2 e'' \right] \quad (25)$$

With the aid of Eqs. (2) and (25), the capacitive component of the FET current can be readily calculated:

$$i_2(t) = C \frac{d}{dt} [i_1(t) R_1(t)] \quad (26)$$

After neglecting second-order terms, $i_1(t)$ and $i_2(t)$ become, respectively:

$$i_1(t) = \frac{1}{R + R_0} \left\{ (1-\rho)e - \left[1 - \left(1 - \frac{R}{R_0} \right) \right] T_p e' \right\} \quad (27)$$

$$i_2(t) = \frac{1}{R} \left[1 + \frac{R}{R_0} \rho \right] T_p e'. \quad (28)$$

Considering the load current given by Eq. (4) and multiplying by R , the load voltage becomes

$$e_0(t) = \frac{R}{R + R_0} \left[(1-\rho)e + \frac{R_0}{R + R_0} \left(1 + 2 \frac{R}{R_0} \rho \right) T_0 e' \right], \quad (29)$$

where $T_0 = R_0 C$ is the FET time constant.

4. CLOSED-LOOP OPERATION

The differential output voltage in closed-loop operation will now be studied.

The time-varying part of the resistance can be written in its normalized form as

$$\rho(t) = \alpha v_c(t), \quad (30)$$

where α is the slope of the linear portion of the curve shown in Fig. 5, and $v_c(t)$ is the FET control voltage. The curve has been obtained considering the slope of the drain characteristics at the origin, as a function of the gate voltage. A feedback technique was used in the experimental set-up to extend the linear region of operation of the FET.

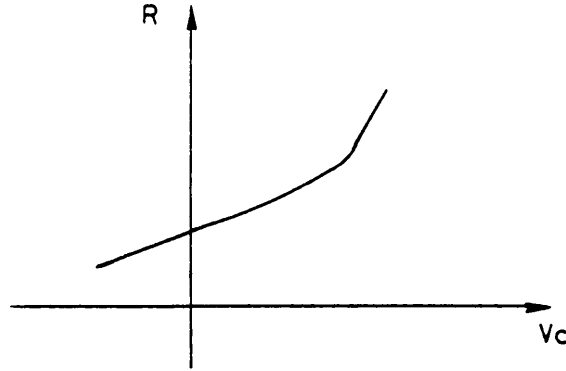

Fig. 5

Referring to the block diagram of Fig. 2, the bridge error-voltage can be expressed as the difference of the two attenuator output voltages, which can be written, considering Eqs. (29) and (30), as

$$e_{01} = A \left[(1 + \alpha v_c) e_1 + (B - D\alpha v_c) T_0 e_1' \right] \quad (31)$$

$$e_{02} = A \left[(1 - \alpha v_c) e_2 + (B + D\alpha v_c) T_0 e_2' \right], \quad (32)$$

where the following constants have been introduced for simplicity:

$$A = \frac{R}{R + R_0}; \quad B = \frac{R_0}{R + R_0}; \quad D = \frac{2R}{R + R_0}.$$

Replacing the input voltages

$$e_1 = [1 + h(t) + g(t)]f(t) \quad (33)$$

$$e_2 = [1 - h(t) - g(t)]f(t) \quad (34)$$

in Eqs. (31) and (32) and taking their difference, the error voltage becomes

$$e_s = 2A \left\{ (h+g)f + BT_0 [(h+g)f]' + \alpha v_c [f - DT_0 f'] \right\}. \quad (35)$$

The synchronously detected signal can be calculated taking the product of Eq. (35) and the sum of Eqs. (33) and (34):

$$e_m = 4AK_m \left\{ (h+g)f^2 + BT_0[(h'+g')f + (h+g)f']f + \right. \\ \left. + \alpha v_c [f^2 - DT_0ff'] \right\}, \quad (36)$$

where K_m is the multiplier constant, in V^{-1} .

Choosing a high enough time constant, the low-pass filter will act as a pure integrator over the frequency range of interest, the filtered output being

$$e_d = \left[\int_0^t (h + BT_0h' + \alpha v_c) f^2 dt + \right. \\ \left. + \int_0^t (g + BT_0g') f^2 dt + \right. \\ \left. + \alpha D \cdot T_0 \int_0^t v_c ff' dt + \right. \\ \left. + B \cdot T_0 \int_0^t hff' dt + \right. \\ \left. + B \cdot T_0 \int_0^t gff' dt \right] \frac{4AK_m}{T_i}. \quad (37)$$

The contribution of the last four integrals is negligible due to the fact that g and f are fast-varying functions, being smoothed out by the comparatively long time-constant of the filter.

The voltages h , h' , and v_c are slowly varying time functions, and can be taken out of the integral as being constants during the repetition period of the positive-defined squared carrier f^2 .

In closed-loop operation the control voltage becomes $v_c = G \cdot e_d$, where G is the voltage gain of the stages following the low-pass filter.

Rearranging the terms, the control voltage can be obtained from Eq. (37):

$$v_c = \frac{(4AK_m G/T_i)(h + BT_0h') \int_0^t f^2 dt}{1 - 4K_m \alpha G A/T_i \int_0^t f^2 dt}. \quad (38)$$

The differential output from the bridge can now be obtained by introducing Eq. (38) into Eq. (35). With the additional condition that the loop gain is high, i.e.

$$\frac{4AK_m \alpha G}{T_i} \int_0^t f^2 dt \gg 1 ,$$

the following result is obtained:

$$e_s = 2A \left[gf + BT_0(g'f + gf') + \right. \\ \left. + [B+D]T_0hf' + BDT_0^2h'f' \right] . \quad (39)$$

As expected, the $(h \cdot f)$ term has been completely removed, but other terms have been introduced. They all come from the transmission zero due to the shunt capacitance of the FET, the last one being negligible because of its T_0^2 dependence. The first derivative of $(g \cdot f)$ corresponds to a leading phase shift of the transmitted signal, having no harmful effect in general. The remaining term still contains information coming from the h modulating component, and has to be considered as a systematic limitation of the method affecting its high-frequency performance. Nevertheless, both of these undesirable terms are T_0 dependent, so their influence on circuit behaviour can be reduced by a careful choice of the FET.

In the following section a particular application of the circuit is analysed, and its limitations considered quantitatively.

5. CLOSED-ORBIT SIGNAL SUPPRESSOR

The transverse position of the beam in the PSB is measured with an electrostatic pick-up, consisting of two electrode pairs (one for the vertical, the other for the horizontal position).

The signal appearing on each plate consists of an approximately half-sinusoidal carrier (reflecting the bunched distribution of charge along the beam), amplitude-modulated in opposite phase by the position of the beam, relative to the centre of the vacuum chamber, in the plane considered. The position of the beam can always be taken as the superposition of an equilibrium position and variations relative to it, caused by transverse instabilities. The equilibrium position (closed orbit) is essentially constant and varies only slowly during the machine cycle. The instabilities have a wide spectrum of frequencies, depending on the operating conditions of the machine. Under normal operating conditions, the lower cut-off of their frequency spectrum is substantially higher than the upper cut-off of the closed-orbit frequency spectrum.

In terms of amplitude, the closed orbit can be an appreciable part of the vacuum chamber aperture, depending on the machine operating conditions and the azimuthal position of the pick-up. The instabilities, if undamped, can have quite

large amplitudes. If the transverse damping system is effective, however, their amplitude is kept to a negligible value (which is, in fact, the aim of the damping system).

It is therefore possible to represent the signals on the two plates of a given pair in a pick-up by expressions such as those in Eqs. (33) and (34), where $f(t)$ represents the bunch-shaped carrier, and $h(t)$ and $g(t)$ the closed-orbit and the instability components of the modulating signal.

A feedback system, taking its input signal from an electrostatic pick-up, has been developed for damping out the beam transverse instabilities²⁾. The difference between the waves from the two pick-up plates is used as the feedback signal for the system. The power of the output amplifiers is strongly dependent on the closed-orbit component of this signal, while the damping action of the circuit is independent of it. The closed-orbit component of the differential signal can be drastically reduced by feeding the arms of the self-balancing bridge, described above, with the signals from the pick-up plates, and using the output from the bridge as a closed-orbit-suppressed differential signal for the feedback system.

In order to get a quantitative picture of the performance, a suppression factor will be defined as the ratio of the power contents of the differential output signal due to the closed orbit component ($g = 0$) in open- and closed-loop conditions, i.e.

$$F = \frac{\text{Power content of } e_s \text{ without suppression}}{\text{Power content of } e_s \text{ with suppression}} .$$

Considering the Fourier development of the signals and the fact that $h(t)$, being a very slowly varying function, can be considered as a constant during the repetition period of $f(t)$, the power contents become those of $f(t)$ and $f'(t)$, respectively, multiplied by their corresponding constants

$$F = \frac{\sum c_n^2}{(B+D)^2 T_0^2 \sum n^2 c_n^2 \omega_0^2} , \quad n = 1, 2, 3 \dots , \quad (40)$$

where c_n are the Fourier coefficients of $f(t)$ and ω_0 is its repetition frequency.

A practical version of the circuit has been built^{3,4)} using a 2N 4416 FET and the following circuit parameters:

$$(B+D) = 1.2 ; \quad T_0 = 0.4 \text{ ns} .$$

For a sinusoidal carrier, the form factor

$$\frac{\sum c_n^2}{\sum n^2 c_n^2} = 1 ,$$

while for a semisinusoidal carrier it reaches a value of 0.65.

For the highest repetition frequency of the Booster carrier, $\omega_0 = 5 \times 10^7 \text{ s}^{-1}$, a suppression factor in excess of 10^3 is obtained when the preceding values are substituted in Eq. (40). Owing to FET non-linearities, a second harmonic component appears in the differential output voltage, placing a threshold on the maximum attainable suppression factor.

Acknowledgements

This work was done while one of the authors (C.F.C.) was on leave of absence from La Plata University, Argentina. He would like to thank CERN for its hospitality and K.H. Reich for his continuous encouragement and support. H. Fauchiotti, also from La Plata University, contributed a valuable suggestion for the mathematics.

REFERENCES

- 1) L. Pipes and L. Harvill, Applied Mathematics for engineers and physicists (Mc Graw-Hill, Inc., New York,
- 2) G. Gelato and H. Schönauer, Proposal for a transverse feedback damping system for the PSB, PS/BR Note/77-32 (1977).
- 3) C. Christiansen, Closed-orbit signal suppressor for the transverse feedback of the PSB, CERN Internal Report PS/BR 80-5 (1980).
- 4) C. Christiansen, Linear phase filter for the transverse feedback of the PSB, CERN PS/BR Note/80-5 (1980).

Distribution (Abstract):

Club des électroniciens