

EUROPEAN ORGANIZATION FOR NUCLEAR RESEARCH

CERN/PS 87-35 (BR)

ADAPTING THE CERN PS BOOSTER TO OXYGEN ACCELERATION

C. Carter, J. Fopma, G. Gelato, L. Magnani, P. Odier, K. Schindl
PS Division

Paper presented at the 1987 Particle Accelerator Conference
Washington D.C., March 16-19, 1987

ADAPTING THE CERN PS BOOSTER TO OXYGEN ACCELERATION

C. Carter, J. Fopma, G. Gelato, L. Magnani, P. Odier, K. Schindl
CERN, 1211 Geneva 23, Switzerland

Introduction and Summary

After the successful experience of passing deuterons and alphas through the PSB for achieving more intense beams in the late ISR, it was decided to include the PSB in the CERN oxygen ion acceleration programme. Particular features of this project are : (i) development of high sensitivity instrumentation and low-level electronics to handle some 10^8 charges; (ii) RF gymnastics required to cover the large frequency range ; (iii) operation of the ion programme while continuing to provide the other users with protons. New instrumentation, such as several types of beam transformer, are described. The extension of the radial position and phase detection systems towards these low intensities, enabling the beam to be accelerated in closed loop, is presented. Difficulties arising from the pulse-sharing mode (10^8 and 10^{11} charges/ring) to be accelerated on alternate cycles) will be discussed in the light of recent beam tests.

Oxygen in the PS Booster - Basic features

The reasons for including the PS Booster into the ion acceleration scheme [1] [2] (rather than injecting into the PS) were (i) boosting the intensity available for the downstream machines by a factor 3 ; (ii) easing the task of the PS machine, already heavily charged with p, p, and lepton acceleration, in pulse-sharing mode.

Linac beam [3] and injection. The "old" 50 MeV (p) linac provides $15-35 \mu A$ of O^{8+} with a pulse length of some 100 μsec . Emittances and momentum spread of this beam are near to the corresponding p figures, but its intensity varies strongly within the pulse and from pulse to pulse. Employing the proton injection scheme, the ions are distributed to the four levels and injected by means of betatron stacking (~ 7 turns) into each of the rings.

RF trapping, acceleration, RF gymnastics. The frequency swing of the RF cavities (3-8 MHz), designed for p acceleration on $h=5$, is not sufficient to cover the β -swing for ions (a factor 4 if $q/A = 1/2$) Therefore the ions are adiabatically captured into 10 buckets per ring and accelerated to 48 MeV/amu where the harmonic number is changed from 10 to 5 by a debunching, re-trapping process on an intermediate magnet flat top of ~ 50 msec length. 5 bunches per ring are then accelerated to the magnetic rigidity on which p are normally transmitted to the PS, corresponding to 260 MeV/amu.

Transfer to PS. As for p, the four beams are synchronized between rings, ejected, recombined to one level, and injected into 20 PS buckets out of which however only 16 can be filled because of insufficient pulse length of the 8 kicker magnets involved. Oxygen batches of about $3-6 \cdot 10^8$ charges per batch, and with other beam properties reminiscent of typical proton beams, are available every 1.2 sec.

Pulse-sharing operation ("PPM") The PS complex delivers O^{8+} to the SPS while providing other users with protons or deuterons (coming from Linac 2) or leptons (new injector chain) on alternate magnet cycles. In the PS Booster, the settings of elements otherwise constant have to be changed from cycle to cycle, notably (i) ~ 20 power supplies in the linac-

PSB line and the rings to adapt to a 5% difference in magnetic rigidity between p and ions ; (ii) timings to cope with the 100 msec increase in cycle length as well as with the RF gymnastics for ions ; (iii) RF frequencies at injection, at re-capture and ejection. Implementing this modulation was fairly straightforward as the CPS control system was designed for PPM from the start [4]. However, the dramatic change in intensity between protons (up to 10^{13} /ring) [5] and ions ($\sim 10^8$) called for special measures in the RF low level electronics.

RF low level electronics

Of the 13 feedback loops in the accelerating system of each ring, those meant to damp instabilities needed only to be switched off (in PPM). The following 4 loops required extensive modifications :

1) Radial. The radial normalizers [6] [7] derive the position from electrodes supplying an intensity (I) and an (intensity*position) signal (Δ). Operation down to $\approx 2 \cdot 10^7$ charges/ring requires ≈ 110 dB of dynamic range. PPM switched amplifiers (60 dB) were introduced on Δ and I, and the normalizers modified to obtain ≈ 70 dB of dynamic range on I, thus providing 10 dB of range overlap. To extend downwards the dynamic range, the noise bandwidth was reduced by converting all signals to a fixed 10.7 MHz frequency and filtering with crystal filters (± 150 kHz). A coarse AGC maintains a correct level at the input of the mixers, and a precise one acts on the (I \pm Δ) signal after the filter to provide an intensity-independent position signal (Fig. 1). Switching transients that would saturate the AGC at high gain are suppressed by pulsed gain reduction. This technique leads to an increase in the AGC response time which nevertheless remains below 100 μsec for full gain excursion. The local oscillator (L.O.) used for the normalizers is also serving the phase and synchronization loops [8][9].

2) Phase. The required dynamic range (≈ 130 dB including adiabatic trapping) was compressed to ≈ 110 dB by turning on the loop only after the adiabatic rise (not possible at high currents because of beam loading). A dynamic range of ≈ 80 dB plus a switched gain of 60 dB provide an overlap of 20 dB. Here too the noise bandwidth was reduced by conversion to

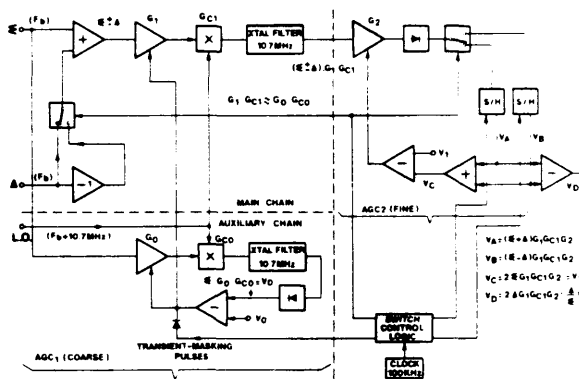

FIG 1 RADIAL POSITION NORMALIZER

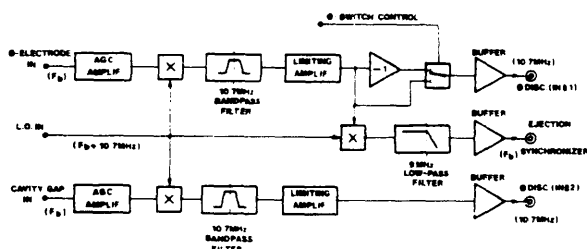

FIG. 2 - LOOP SIGNAL FILTERING

10.7 MHz followed by filtering (crystal filters were not used because of their excessive group delay). An AGC amplifier assures the correct level for the mixer, and a 10.7 MHz limiting amplifier provides enough signal for the phase discriminator. The other input to the discriminator (RF cavity voltage) is converted to the same frequency through an identical chain, using the same L.O.; this automatically cancels the effects on phase of the delay in the electronics and of the L.O. phase variations (Fig. 2). Stray RF picked up by the signal cables from the phase electrodes proved a serious problem at low intensities. Breaking the ground loops with transformers helped; differential transmission is planned for further improvement.

3) Synchronization at ejection. Bunch-to-bucket transfer to the PS requires phase-locking the four rings and the PS RF system to a common reference oscillator. To bring the signals to the same frequency, the "clean" signals at 10.7 MHz carrying bunch phase information are down-converted to the RF frequency (same L.O. as for up-conversion, cancellation of L.O. phase variations (Fig. 2)). To cope with different ions, a remotely (PPM) controlled synthesizer is used as reference oscillator.

4) Injection frequency control. The setting of the injection frequency in PPM is done by a remotely controlled synthesizer to which the rings are frequency-locked with individually (PPM) controlled offsets (to compensate for differences in the magnetic field between rings and energy variation along the Linac beam).

RF "gymnastics". The harmonic number is changed from 10 to 5 on a flat top, when β has twice the value at injection (Fig. 3). The RF voltage is dropped to ≈ 600 V, the minimum operating voltage, and the frequency ramped down to a value near the injection frequency in about 20 ms. To keep the empty buckets away from the beam during the cavity settling, a frequency offset of a few tens of kHz is applied. It is then quickly removed and the trapping process is repeated as at injection. A set of timing pulses, enabled or disabled in PPM, controls this operation. Due to the azimuthal positions of the 5 phase electrodes, optimized for $h = 5$, their signals must be phase-inverted when changing from $h = 10$ to $h = 5$. This is done in the 10.7 MHz chain (Fig. 2).

Instrumentation

Existing sensors were used whenever possible, adapting the electronics to lower signals. Injection line beam transformer was equipped with an extra preamplifier. Interference from various pulsed injection devices downstream of the transformer saturated the preamplifier. A temporary solution was to delay the injection timing relative to the linac beam during observation, effectively turning the measurement into a destructive one (Fig. 6).

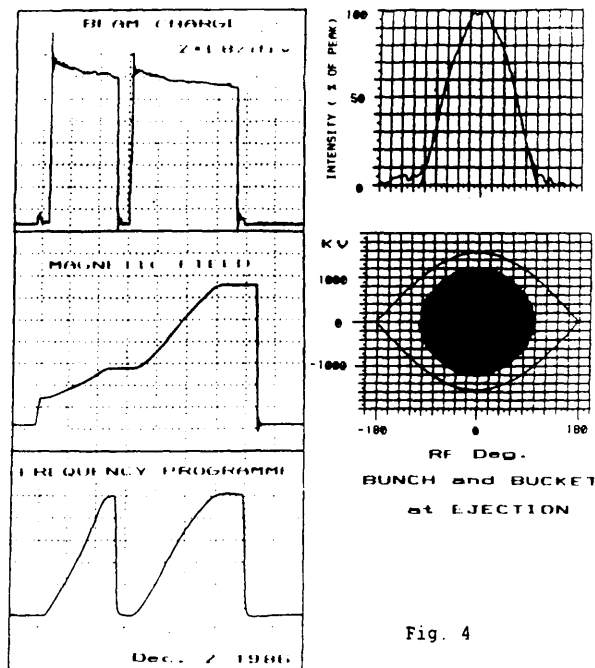

Fig. 3

The existing fast transformers in the rings were adapted to measure the circulating beam by peak-detecting the negative signal between bunches, proportional to the bunched beam current. This does not work before adiabatic trapping, nor during the debunching required to change harmonic number. The signal is amplified before, and β -normalized after detection. An EPROM-stored look-up table controls the gain as a function of the magnetic field, providing a real time analogue output proportional to beam charge (Fig. 3). Different tables applying to different q/A are PPM selected.

In the ejection line transformer amplification was introduced, but strong (though reproducible) interference from kickers forbade the use of the existing gated integrator. The technique used consists in digitizing the interference without beam with a fast digitizer, and memorizing it. Subsequent digitization of the perturbed beam, then subtraction of the stored perturbation, plus numerical integration yield the required result. A filter had to be used to avoid saturating the preamplifier on interference spikes; bunch shape information was thus lost.

Longitudinal emittance measurement [10]. An amplifier (≈ 40 dB) was added to adapt the monitor's level (Fig. 4) to the digitizer's dynamic range. Although usable, the accuracy of the results is limited by the poor S/N ratio at very low currents.

Transverse emittance measurement. Beam profiles were measured with the "BEAMSCOPE" device [11], which proved to work correctly at these low intensities using the peak-detected signal of the fast ring beam transformer (Fig. 5).

Scintillators screens. Extrapolating from experiments with deuterons, the screens in the PSB-PS line were replaced by more sensitive ones ($Al_2O_3 + 0.5\% \text{ of } Cr_2O_3$) and the TV cameras were equipped with Philips' NEWVICON XQ 1440 image tubes.

AMPLITUDE PROFILES

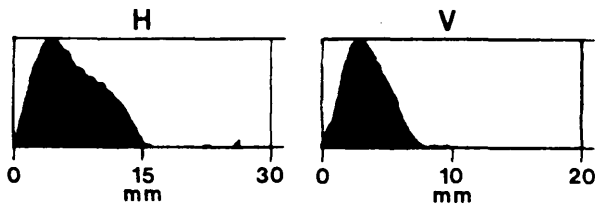

Fig. 5 : Beam profiles measured with "Beamscope"

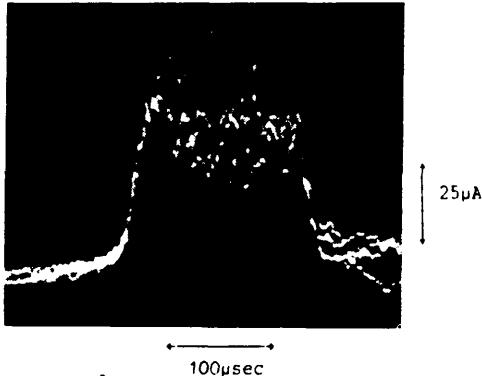

Fig. 6 : 0^8+ beam intensity measured in the LINAC-PSB line. 4 pulses superimposed

Performance [12]

Typical sum-of-four-ring intensities and efficiencies, together with target figures, are given in Table 1; some of the beam properties, measured during the 1986 physics run, are presented in Table 2. The performance is affected by strong variations of the linac current within a pulse and from pulse to pulse (Fig. 6).

Table 1 : Typical oxygen intensities and efficiencies

	#Charges [10 ⁸]	Efficiencies(%)	
		obtained	target
From Linac 1	14.0		
PSB 1st capture	8.0	57	63
PSB accelerated	6.0	67	85
Entry PS	4.5	75	80 ¹
Entry PS/entry PSB		32	43

¹ Only 16 out of 20 bunches transferred to PS

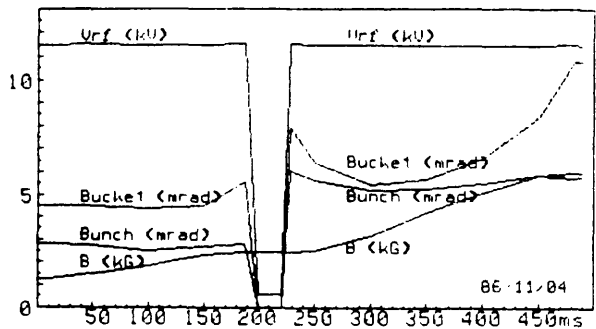

Fig. 7

Table 2 : Oxygen beam properties, PSB

	ϵ_H [10 ⁻⁶ vradm]	ϵ_V	$\frac{\Delta P}{P}$ [%]	Bunch area [eVs] [mrad]	
From Linac 1 (11.4 MeV/amu)	20	20	±0.1	0.03 ²	2 ²
After 1st trapping	~ 120 ¹	~ 30		0.04	2.5
At PSB exit (260.7 MeV/amu)	25	7		0.15	4.8

¹ enlarged ϵ_H after horizontal betatron stacking
² equivalent, ϵ_H for h=10

During acceleration, the transverse emittances are supposed to shrink by a factor 5, thus there is a moderate vertical blow-up. However, the bunch area is diluted by a factor 2 (Fig. 7), but these beam properties are still adequate for the PS.

Outlook

Depending on the future of the CERN ion programme and its implications on the PSB (e.g. partially stripped ions), a certain amount of improvements are considered, notably (i) further reduction of parasitic noise on the phase and radial detection systems, together with (ii) a more careful programming of RF voltage and frequency, to avoid longitudinal beam dilution and losses during acceleration; (iii) lengthening of the extraction kickers' pulse duration for lossless transmission to the PS. Sources of even heavier ions are likely to produce intensities insufficient for the beam control loops, therefore the possibilities of open-loop acceleration and related topics are being looked into. Partially stripped ions in the PS Booster would require an improved ring vacuum (from the present 10⁻⁸ down to 10⁻⁹ torr) in order to avoid stripping losses on the rest gas; a study is underway.

References

- [1] K. Schindl, CERN Internal Note, PS/BR/Note 81-10, June 1981
- [2] J. Fopma et al., CERN Internal Note PS/BR Note 83-2, September 1983
- [3] H. Haseroth et al., Proc. 1986 Lin. Acc. Conf., Stanford, June 1986
- [4] G.P. Benincasa, F. Giudici, P. Skarek, IEEE Trans. Nucl. Sci., Vol. NS 28, N° 3, June 1981
- [5] G. Gelato et al., this conference
- [6] G. Gelato, L. Magnani - CERN Internal Report MPS/Int. BR/75-8, June 1975
- [7] G. Gelato, L. Magnani - Proc. 1977 Part. Acc. Conf. - Vol. NS-24, N° 3, June 1977, pp. 1536-38
- [8] G. Gelato, E.J. Tacconi - CERN Internal Report PS/BR/Note 85-1, April 1985
- [9] E.J. Tacconi - CERN Internal Report - PS/BR/Note 85-2, April 1985
- [10] G. Gelato - CERN Internal Report PS/BR/Note 82-10, June 1982
- [11] H. Schönauer, IEEE Trans. Nucl. Science, Vol. NS-26, p. 3294 (1979)
- [12] E. Brouzet, W.C. Middelkoop, this conference