

# Chapter 1 Introduction, scope, and schedule

*J. Bernhard, S. Evrard, E. Harrouch*

## 1.1 Introduction

### 1.1.1 Motivation

The East Area of the CERN Proton Synchrotron has served the physics community for over 50 years and remains extremely popular and necessary, among other things, to complete full calibration over a large energy spectrum of the detectors to be installed in the Large Hadron Collider (LHC) experiments according to the needs of the upgrade for the High Luminosity LHC. In addition, physics programs like CLOUD [1], and test facilities such as IRRAD [2] and CHARM [1][3] are based on a reliable and easily maintainable East Area.

A detailed study was carried out over the years 2009–2015 and presented at the Consolidation Day on the 11th of February 2016 [4] following a request to optimize the activities with a focus on what is required for operation in line with the physics community needs.

The East Area renovation is considered as a priority for the Organization and sufficient funds were made available in the Mid Term Plan (MTP) approved by Council in June 2016 to allow the major work to be completed by the end of the Long Shutdown 2 (LS2). Therefore, the Accelerator & Technology Director appointed a project team to take responsibility for the completion of the work.

The East Area renovation covered the refurbishment of the East Hall with its beamlines and infrastructures. A redesign of the beamlines was included to improve the magnet and radiation situation in general. The performance of the new beamlines was improved in terms of maximum momentum and in choice of particle type. Thanks to a cycled powering mode of the magnets instead of a steady state one, considerable energy savings are now possible.

This report summarizes the various detailed studies completed from 2016 to 2019 and outlined in Ref. [5].

## 1.2 Scope of the renovation

Following the mandate of the Accelerator and Technology Sector Directorate [6], the main goal of the renovation was to ensure the long-term operation of the PS East Area experimental area facility. Practically, this was achieved by implementing a new beamline layout, a new cycled powering scheme, and thoroughly refurbishing the associated infrastructure with the following objectives/means.

The new beamline layout:

- better cope with physics requirements (maximum momentum and choice of particle type (e, h,  $\mu$ ));
- minimize dose rates to personnel, and allow faster repair times by improving equipment accessibility;
- respect today's norms for radiation protection: new primary area ventilation + new dump system.

The new cycled powering scheme:

- replaced massive magnet yokes by laminated ones to allow cycling them;
- installed new SIRIUS power converters with energy recovery capacitor banks;
- allows to reduce the annual electrical energy consumption from 7 to 1 GWh for powering the magnets.

Infrastructure renovation:

- upgraded Building 157 envelope (wall and roof cladding) with a particular effort on thermal insulation, allowing for an annual energy consumption reduction from 3 to 1 GWh;
- sanitized the building and got rid of asbestos;
- separation of primary and secondary beams and zones cooling circuits.

A new beamline layout, as illustrated in Fig. 1-1, which addresses most of the issues related to the previous layout.

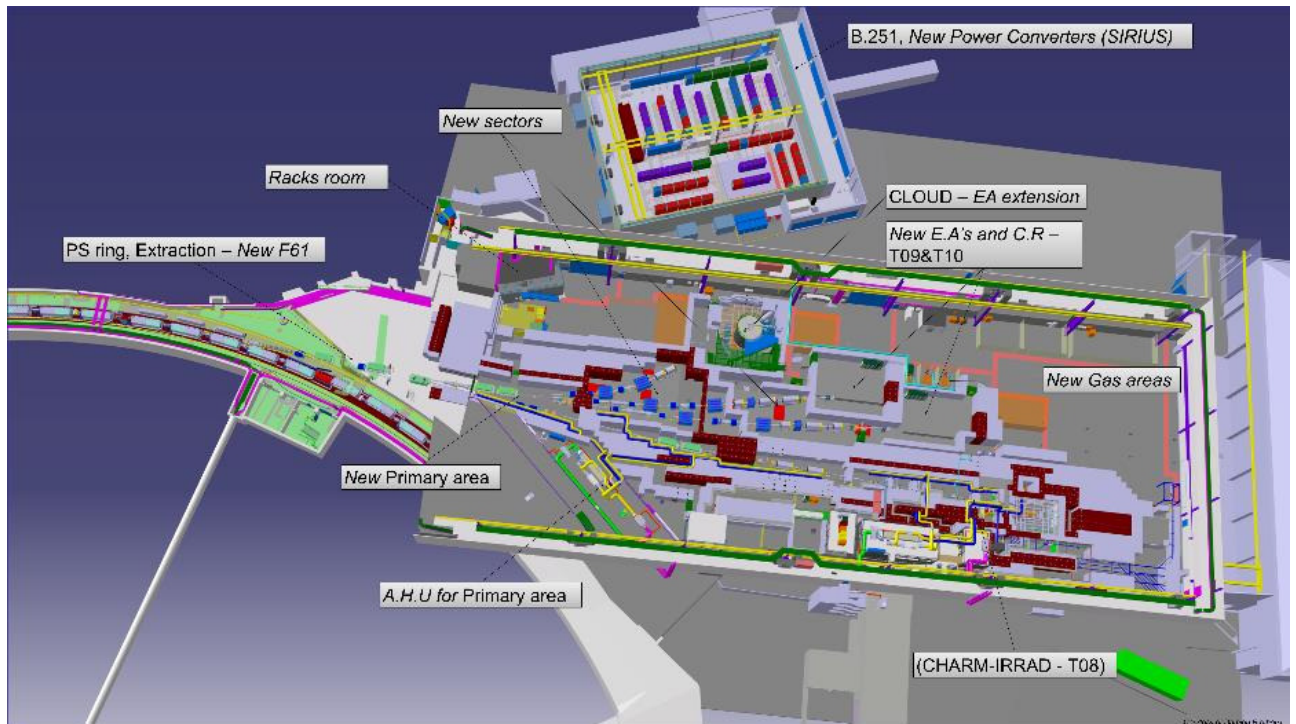

**Fig. 1-1:** New layout of the East Area.

### **1.2.1** *Beamline: design and layout*

Before renovation, the primary beam was extracted from the PS into the F61 beamline and could be sent either to the T08 beamline used by IRRAD and CHARM or to the north target to produce secondary beams for the experimental areas (T09, T10, and T11), as can be seen in Fig. 1-2.

After renovation, the primary beamline of the IRRAD/CHARM main parameters and optics remained nearly unchanged. These parameters can be consulted in Table 1-1.

The North branch of the beamlines was modified to host two targets and allow a better performance of the secondary beamlines (particle selection, maximum momentum, etc.).

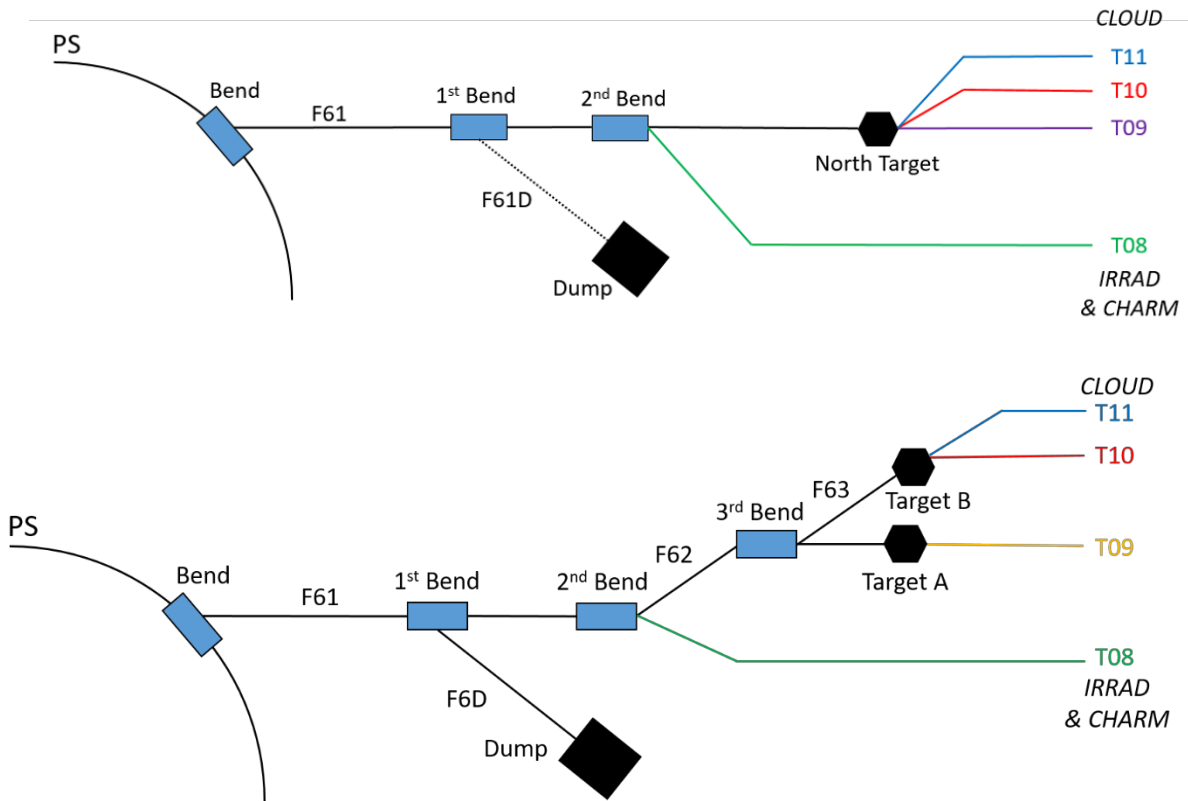

Fig. 1-2: Schematic view of the layout in the East Area before (top) and after (bottom) renovation.

Table 1-1: Main parameters of the primary beam.

Parameter	Value
Proton beam momentum [GeV/c]	24
Maximum # spills per typical super-cycle	6
Duration of typical super-cycle [s]	45.6
Maximum # protons per second	$6.7 \times 10^{10}$
Maximum assumed number of days of operation per year	200
Assumed efficiency	90%
Maximum number of super-cycles per year	340 000
Maximum number of protons per year	$1.0 \times 10^{18}$

In the new design, the secondary beams are produced at target B for T10 and T11, and target A for T09 with a vertical angle of 30 mrad with respect to the primary beam. This allows for clean stopping of the primary beam (the part which does not interact with the targets) into a dedicated beam dump independently of the secondary beams. In the pre-LS2 configuration, the primary beam was dumped in the magnets themselves (causing high residual radiation and ageing of beamline components). The beam parameters for the new T09 and T10 beamlines are presented in Table 1-2. It should be noted that the new T11 beamline has a maximum momentum of 3.6 GeV/c as before.

**Table 1-2:** Beam parameters for the new T09 and T10 beamlines. For convenience, a comparison to the old T09 values is given in addition.

<b>Parameter</b>	<b>T09 (old)</b>	<b>T09 (new)</b>	<b>T10 (new)</b>
Length up to the last element [m]	54.3	50.2	44.7
Max. momentum [GeV/c]	10	15	12
Momentum resolution	0.7 %	0.7 %	0.7 %
Max. momentum band		±15 %	±15 %
Horizontal acceptance	±4.8	±4	±5
Vertical acceptance	±4	±3.8	±3
Horizontal magnification at final focus	0.81	0.86	0.92
Vertical magnification at final focus	0.91	0.9	0.58
Max. flux per spill	10 <sup>6</sup>	10 <sup>6</sup>	10 <sup>6</sup>

### 1.2.2 *Beamline: Hardware*

To be able to change from a continuous to a pulsed power supply, the yokes of the magnets needed to be laminated. In addition, over the final years of operation, maintainability of the magnets became a critical issue mainly because of long cooldown, repair times, and the lack of spares for some magnet families. These two reasons drove the need for the complete renovation of the magnets in order to install new magnets with laminated yokes and of fewer families.

With the same philosophy concerning maintainability, components such as beam stoppers or collimators were replaced with standard equipment. Beam instrumentation were also modernized using, for instance, (recently developed) beam profile monitors and scintillating fibres.

Control of the beamline was greatly improved with the implementation of a magnet protection system or remote control of the vacuum system and remotely controlled collimators.

### 1.2.3 *Buildings 157, 251, and 352: infrastructure consolidation*

**Building 157**, which hosts the primary area, the secondary beamlines, the CLOUD experiment, the IRRAD and CHARM facilities, as well as the T09 and T10 test beam areas was renovated mainly in the North part of the building. In fact, the IRRAD and CHARM facilities remained unchanged as the south part had already been redone in 2013–2014.

To comply with the power consumption reduction, some services such as AC powering and the cooling network were downsized and renewed according to lower operation requirements.

To cope with the new optics, the shielding of the primary area was completely modified to satisfy the radioprotection requirement, and to reduce the time needed to open it in case an equipment needs to be exchanged.

The access system was also renewed and the size of the high activation areas was reduced to limit the exposure of workers during maintenance.

The experimental area services were upgraded (T09, T10, and T11): new control rooms, new gas distribution, dedicated areas for detector/experiment set-up, etc.

The building's envelope was completely refurbished to eliminate asbestos and improve greatly the thermal insulation within the building.

**Building 352**, which houses part of the PS ring and the extraction line towards the East Hall, saw most of the modifications in the F61–F62 and F6D beamlines. Following the renovation strategy, these lines were also renovated (new magnets and power converters, standard beam stoppers, etc.). The infrastructure remains generally identical but required a new cooling circuit and new cabling to match the new layout.

**Building 251, which** hosts all the power converters, was renovated to adapt to the new configuration and requirements of the new beamlines.

The previous power converters had become unreliable and were replaced by different types of modern SIRIUS power converters, including SIRIUS S, 2P, 4P, and 4P+. Since these new power converters have different characteristics (weight, size) compared to the old ones, the structures on which these converters are installed, the electrical supply system, and the cooling system was redone during the renovation.

In particular, the following actions took place during the renovation in LS2:

- i) Renewal of the false floor to support all the power converters.
- ii) New cooling network and ventilation dedicated to the power converters.
- iii) Renewal of the electrical infrastructure to provide AC current to the power converters.
- iv) Re-organization of the DC cabling to connect the power converters to the magnets in Building 157.

### **1.3 Project cost and schedule**

#### ***1.3.1 Project cost***

The cost to completion of the renovation project budget amounts to 30 MCHF. Four fifths are dedicated to material expenditures and the rest to personnel. In order of importance, the cost drivers are power converters, magnets, civil engineering, electrical systems, cooling, and ventilation.

#### ***1.3.2 Schedule***

The project officially started in July 2016 with detailed study phases in 2016, 2017, and 2018. In parallel to 2018 beamline operation, the Site Management and Buildings department carried out the renovation of the whole of Building 157 including walls, windows, and roof. The vast majority of consolidation activities took place during the Long Shutdown 2 within a 36-month beam-to-beam. The primary area and the primary beamline area in Building 352 were the most critical and challenging zones with regards to schedule and workload constraints. It is also worth mentioning the CLOUD runs without beam, which took place in Autumn 2019. Due to the Covid-19 pandemic, the initial schedule has been extended by 6 months, targeting a restart of physics run by October 2021.

### **1.4 Safety**

The renovation of the East Area has ensured that the present level of safety is maintained and improved (whenever possible) during all project phases (from the design phase until the operation of the facility). This will be demonstrated in a dedicated safety file. The main objectives of the project in terms of safety are the following.

- i) Reduce the exposure to ionizing radiation during the maintenance of the facility (especially the primary area).
- ii) Bring the facility up to the modern safety standard in term of radioprotection (dynamic confinement in the primary area, separation of cooling circuits, etc.) and conventional safety (refurbish the obsolete electrical infrastructure, reduce the risk of falling, etc.).
- iii) Design an adequate system to safely operate the facility in its new configuration (new access systems, beam intercepting devices, safety matrixes, etc.).
- iv) Ensure the structural resistance of all the shielding assemblies.
- v) Ensure the safe operation of the new power converters which include large energy storage capacitors.
- vi) Respect the ATEX regulations for the design of the new gas distribution system.

## References

Some EDMS documents referenced in this report can be access restricted, access to those can be requested through the EDMS platform.

- [1] CLOUD Greybook: <https://greybook.cern.ch/greybook/experiment/detail?id=PS215>, last accessed May 22nd 2019.
- [2] F. Ravotti *et al.*, A new high-intensity proton irradiation facility at the CERN PS East Area, *PoS TIPP2014* (2015), 354, <http://dx.doi.org/10.22323/1.213.0354>
- [3] CHARM Greybook: <https://greybook.cern.ch/greybook/experiment/detail?id=EA-IRRAD+Mixed-Field>, last accessed May 22nd 2019.
- [4] ATS Consolidation Day, 11 February 2016, link to presentations: <https://indico.cern.ch/event/492100/>.
- [5] L. Gatignon, The East Area upgrade - specifications and cost estimates, [EDMS 1471844](#) (2015).
- [6] F. Bordry, East Area renovation project mandate, [EDMS 1715122](#) (2016).