

PAPER • OPEN ACCESS

Overview and status of the Long Baseline Neutrino Facility cryogenics system

To cite this article: K Haaf *et al* 2019 *IOP Conf. Ser.: Mater. Sci. Eng.* **502** 012124

View the [article online](#) for updates and enhancements.

Overview and status of the Long Baseline Neutrino Facility cryogenics system

K Haaf¹, M Adamowski¹, J Bremer², M Delaney¹, A Diaz², R Doubnik¹, D Montanari¹, B Norris¹, A. Parchet², E Voirin¹

¹Fermi National Accelerator Laboratory, PO Box 500, Batavia, IL 60510 USA

²European Organization for Nuclear Research (CERN), 1211 Geneva-23, Switzerland

Email: khaaf@fnal.gov

Abstract. The Long Baseline Neutrino Facility (LBNF) serves to provide the infrastructure necessary to support the Deep Underground Neutrino Experiment (DUNE), a growing international experiment to study neutrino science and proton decay. Situated at the Sanford Underground Research Facility (SURF), in Lead, SD, USA, DUNE will employ detectors located within massive cryostats filled with a total of 68,400 tons of ultrapure liquid argon. LBNF provides the cryogenic infrastructure necessary to supply and maintain that argon throughout the life of DUNE, as it enables the study of neutrinos from a new and improved beamline from Fermilab, as well as the dynamics of supernovae responsible for producing the heavy elements necessary for life and the possibility of proton decay. This contribution presents the modes of operation, layout, and main features of the cryogenic systems at LBNF. Those systems expected performance, functional requirements, and overall design status is also featured.

1. Introduction

The Deep Underground Neutrino Experiment (DUNE) and Long Baseline Neutrino Facility (LBNF) represent an international collaborative effort in neutrino physics. The combined project is developing the detectors and surrounding infrastructure for a massive neutrino experiment to be located at the Sanford Underground Research Facility (SURF) in Lead, SD, USA. The detectors, termed Time Projection Chambers, reside in cryostats that will each be filled with some 17,100 tons of liquid argon (LAr) with impurities totaling less than 100 parts per trillion (ppt) of oxygen equivalent contamination [1,2]. The DUNE detectors will ultimately enable the study of neutrinos from a new and improved beamline originating from Fermilab.

LBNF includes the four cryostats in which the DUNE detectors reside, as well as the surrounding conventional facilities and cryogenics necessary to receive, transfer, store, purify, and maintain the 68,400 tons of liquid argon (LAr) required for the experiment [3].

The cryostats have internal dimensions of 62.0 m long, 15.1 m wide, and 14.0 m tall, and are passively insulated by 0.8 m of polyurethane foam. The surrounding steel support structure for the cryostats include a 0.012 m thick stainless-steel plate, as well as myriad I-beams bearing the weight of the detector and its contents.

2. LBNF cryogenic subsystems

The cryogenic infrastructure at LBNF is broken into three subsystems: Infrastructure, Proximity, and Internal cryogenics.



The Infrastructure cryogenics include the equipment necessary to receive cryogenics (LAr and liquid nitrogen, LN₂) at an aboveground station, as well as transport the argon to the cavern space, and provide the system refrigeration via the N₂ system with accompanying N₂ storage and distribution. This subsystem, therefore, includes the receiving station itself, the piping connecting the surface facility to the campus below, the entirety of the N₂ system, as well as all accompanying valves and instrumentation. It falls under the purview of the Department of Energy (DOE).

Proximity cryogenics refers to the equipment required to circulate and purify LAr from within each cryostat, as well as the nitrogen-fueled condensers used to re-liquefy boiloff GAr. This system is responsible for achieving and maintaining the high purity of the LAr and includes the gaseous and liquid argon purifiers, regeneration systems, and all interconnecting piping, valves, and instrumentation. It is the responsibility of Non-DOE collaborative partners.

The Internal cryogenics is comprised simply of the equipment required to distribute argon within the cryostat during the different phases of its operation, including the purge, cool down, and fill. It is also responsible for re-introducing purified LAr back into the cryostat from the Proximity cryogenics subsystem. The Internal cryogenics is the responsibility of the DUNE collaboration.

2.1. Operational modes

The cryogenic systems at LBNF function in a variety of operational modes at all phases of the experiment lifecycle:

- **Gaseous argon purge.** Initially, each cryostat will be filled with air. It is imperative to remove air from the cryostats by means of a “piston purge”—that is, a relatively slow flow of warm gaseous argon originating from the bottom of the cryostat, which pushes impurities to the top of the vessel and out to be vented. The argon flows only quickly enough to prevent back-diffusion of contaminants, such as oxygen, water, and nitrogen, reducing each to the order of parts per million (ppm) level prior to the next phase.
- **Gaseous argon circulation.** Following the initial purge, the gaseous argon loop is closed, with GAr sweeping impurities from the bottom to the top of the cryostat and out to a dedicated purification system. The re-purified argon is subsequently reintroduced to the bottom of the cryostat until the contaminant levels are reduced to sub-ppm levels.
- **Cryostat cool-down.** The cryostat and detector must be cooled in a controlled manner—to this end, purified liquid argon is introduced at the top of the cryostat by means of atomizing sprayers. These sprayers mix liquid and gaseous argon, with the resulting mist distributed in the cryostat by means of the second set of sprayers in a uniform process. The cooling required for this mode is supplied by the N₂ system to the condensers located at the mezzanine atop the cryostat.
- **Cryostat filling.** Once the cryostat and detector are cooled to roughly 90 K, they may be filled with purified liquid argon. The argon is initially vaporized and transferred from dewars at the receiving facilities aboveground, filtered within the GAr purification skids blowground, re-liquefied by the nitrogen-fueled condensers above each cryostat and finally used to fill the vessel with LAr. The filling of each cryostat varies in duration, from eight to fourteen months depending on the cooling power available.
- **Steady state operations.** Once filled, each cryostat proceeds to the primary operational phase of the experiment. During this time, the cryostat’s liquid argon must be continually re-circulated through the purification system by means of external pumps. Initially, four pumps per cryostat are used to circulate a large flow through the purification skids; this flow is maintained until the required argon purity level is achieved, at which time the flow (and therefore the number of pumps in operation) is reduced. Boiloff gas is concurrently recondensed in the condensers above the cryostat, combined with the recirculation flow prior to purification, with the total flow reintroduced into the cryostat at the bottom.
- **Emptying.** At the conclusion of the experiment, each cryostat is drained of its liquid argon reservoir. The bulk of the liquid argon is recovered using the external pumps.

2.2. Process Flow Diagram

Figure 1 shows the Process Flow Diagram (PFD) for the cryogenics systems at LBNF. The PFD shows the physical location of major equipment for each subsystem as well as the boundaries and interfaces between them. There are four primary areas at LBNF, with the above and below ground areas connected via the Ross Shaft, and the underground areas interconnected by drifts:

- **Surface.** The cryogenics receiving facilities and compressors building comprises the surface installation at LBNF.
- **Central Utility Cavern (CUC).** The CUC houses the cold boxes, expanders, and the storage for the nitrogen system, as well as the purification skids for GAR and LAr, including the molecular sieves, particulate filters, and the equipment for the regeneration system.
- **Detector Caverns.** The four cryostats are split between two detector caverns on either side of the CUC. The Proximity cryogenics equipment within each cavern include the condensers and phase separators atop the mezzanine above each cryostat, and the LAr circulation pumps beside each cryostat.
- **Ross Shaft.** The Ross Shaft connects the above and underground areas. Gaseous nitrogen and argon are communicated below ground by means of the shaft's piping.
- **Drifts.** The underground drifts connect the Ross Shaft, the CUC, and the Detector Caverns. There are no major pieces of cryogenic equipment within them, aside from piping.

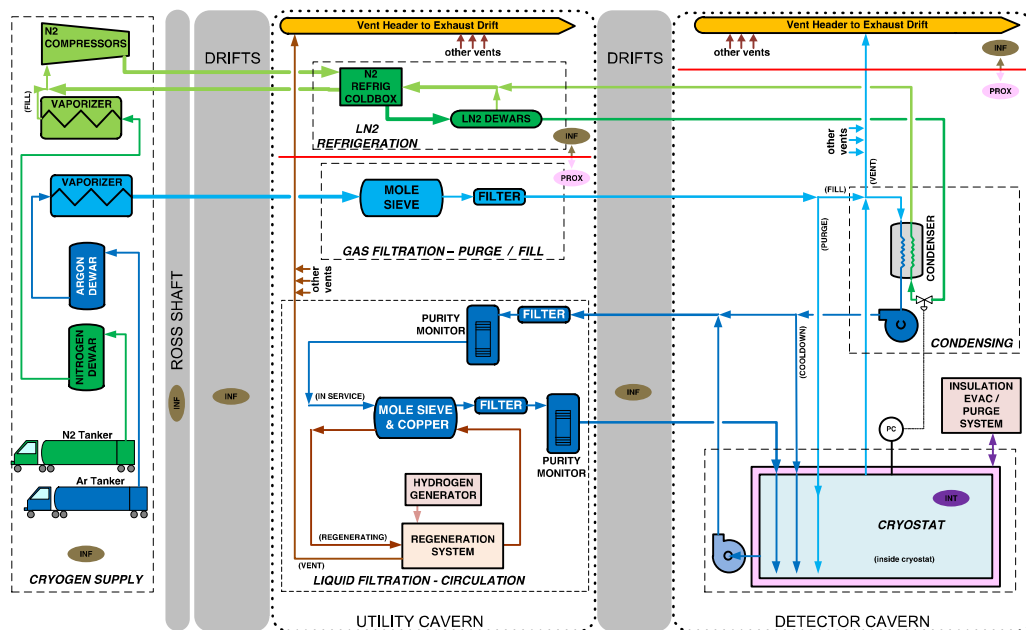

Figure 1: Process Flow Diagram for the cryogenics systems at LBNF.

2.3. Infrastructure Cryogenics

The cryogenics receiving facilities and nitrogen system comprise the primary components of the Infrastructure cryogenics subsystem. The former is situated entirely on the surface, while the latter sees equipment stationed both above and below ground.

2.3.1. Cryogenics receiving facilities. The receiving facilities consist of offloading stations for liquid nitrogen and liquid argon, which are temporarily stored in large dewars; the former is vaporized and compressed in the adjacent compressors building before being communicated underground, while the latter is only vaporized before being sent down the Ross Shaft. The storage dewars, vaporizers, interconnecting piping, valves, and instrumentation to sample the liquid argon for purity are all included in the receiving facilities.

2.3.2. Nitrogen system. The surface nitrogen system equipment includes the large nitrogen compressors within the compressors building. The compressed nitrogen is transported down to the CUC via piping in the Ross Shaft and drifts and enters the nitrogen cold boxes. Each cold box will be capable of delivering 100 kW of nitrogen liquefaction to the nearby storage dewars. Initially, three cold boxes are needed to provide cooling for the operation of the first two cryostats, with a fourth unit added for the third and fourth vessels. During the cryostat cool-down and fill, all available units are employed to minimize the duration of each step. Once all four cryostats are filled and the required argon purity is achieved, three of the four cold boxes will be in use to re-condense boil-off argon, with the fourth being either held in reserve or actively under service. LN₂ is distributed as needed from the storage dewars, with the still-cold spent gas returned to the cold boxes to aid in the N₂ refrigeration process. The cold gas is compressed in smaller booster compressors in order to ascend back to the surface compressors in a closed cycle.

2.4. Proximity Cryogenics

The Proximity cryogenics main components reside in the CUC and within each detector cavern.

2.4.1. Proximity Cryogenics in the CUC. The argon purification system is comprised of liquid and gas filtration elements and the associated equipment required to regenerate them, as well as particulate filters, and includes all of the interconnecting piping and necessary valves and instrumentation. The argon purifiers themselves contain a molecular sieve and copper pellets in order to remove water and oxygen respectively from the argon. Each of the filters, whether for gaseous or liquid argon, are sized to purify argon with contaminant levels of 5 ppm oxygen and 10 ppm water. The gaseous argon purifiers are used during the argon purge phase, with shared filters used for cryostats 1 and 2, with another set of gaseous filters for cryostats 3 and 4. By contrast, the liquid argon filters are actively used throughout the experiment to achieve and maintain the required 100 ppt contamination level, with each cryostat given a set of liquid filters of its own. During operations, the liquid argon filters will switch between active filtration and regenerative modes, with one half of the set either actively filtering or being regenerated, so that the argon filtration process is uninterrupted.

2.4.2. Proximity Cryogenics in the detector caverns. The bulk of cryogenic equipment within the detector caverns sits atop a mezzanine about 2.3 m above each cryostat. The mezzanines are each 12 m wide and 44.6 m long, and contain the liquid argon phase separators, through which liquid argon is passed before returning to the cryostat, the condensers, in which boiloff argon is re-liquefied before being pumped to the argon filtration skids, and the nitrogen phase separators, which serve as brief storage vessels for liquid nitrogen used to power the argon condensers. Additionally, the mezzanine holds all of the cryostats' pressure controls and safety valves, along with PLC racks and a warm gas panel.

On the opposite end of the cryostat and on the lowest level are the four large liquid argon pumps that serve to circulate the bulk of the liquid argon to the CUC for filtration. Argon is withdrawn by the pumps through the four side penetrations near the bottom of the cryostats, each equipped with an in-line safety valve with its seal located within the cryostat itself. The safety valves normally remain open via actuators, but will close down in case of emergency, loss of actuation, or another triggering event. These safety valves are now being used at ProtoDUNE and, if successful, will be employed at LBNF.

2.4.3. Internal Cryogenics. Each cryostat has a set of dedicated internal cryogenics serving to distribute liquid or gaseous argon during through the various operational modes previously described. These consist of manifolds for the gaseous argon purge, the cool-down, and liquid distribution networks. The purge piping manifold sees gaseous argon distributed evenly at the cryostat floor, with multiple pipes runs extending along the length of the cryostat. The cool-down piping is distributed along the top of the cryostat through several penetrations, with only small lengths of pipe and the sprayers themselves

entering the vessel. The liquid distribution piping sits along the long edges of the cryostat and serves to distribute liquid argon within the cryostat during both the fill and the normal operations of the experiment.

3. Summary and Future Steps

This contribution presented a current look at the main features of the LBNF cryogenics systems. The functional requirements specification for the nitrogen system is under review at the time of writing, with an expected Request for Proposals (RFP) to be issued in late 2018. Design efforts on Proximity and Internal cryogenics subsystems continue to inform requirements for the conventional facilities, helping to identify power and instrumentation requirements throughout the facility.

References

- [1] Acciarri R et al. 2016 The Long-Baseline Neutrino Facility (LBNF) and Deep Underground Neutrino Experiment (DUNE) Conceptual Design Report Volume 1: The LBNF and DUNE Projects. ArXiv: 1601.05471.
- [2] Acciarri R et al. 2016 The Long-Baseline Neutrino Facility (LBNF) and Deep Underground Neutrino Experiment (DUNE) Conceptual Design Report Volume 4: The DUNE Detectors. ArXiv: 1601.02984.
- [3] Acciarri R et al. 2016 The Long-Baseline Neutrino Facility (LBNF) and Deep Underground Neutrino Experiment (DUNE) Conceptual Design Report Volume 3: Long-Baseline Neutrino Facility for DUNE Jun 24, 2015. ArXiv: 1601.05823.
- [4] Bremer J et al. 2016 Overview of the development and prototyping of the cryostats and cryogenics systems for the LBNF/DUNE project. Proceedings of the 14th Cryogenics 2017 IIR International Conference.
- [5] Montanari D et al. 2015 Performance and results of the LBNE 35 ton Membrane Cryostat Prototype. Phys. Procedia (Volume 67 C pp 308-313).
- [6] Geynisman M et al. 2017 Design of the cryogenic systems for the Near and Far LAr-TPC detectors of the Short-Baseline Neutrino program (SBN) at Fermilab. To be published in Advances in Cryogenics Engineering: Proceedings of the Cryogenic Engineering Conference (CEC) 2017.
- [7] Adamowski M et al. 2014 The Liquid Argon Purity Demonstrator. JINST 9 P07005.
- [8] Zuckerbrot M et al. 2016 Purge, cool down and filling of MicroBooNE Cryostat. Workshop on Cryogenics Operations, October 2016, Fermilab. <http://microboone-docdb.fnal.gov/cgi-bin/ShowDocument?docid=6671>
- [9] Kim M J et al. 2015 The LBNF Cryogenics Infrastructure at the Far Site. November 2015 update to CDR Annex 3D: Detailed report on the LBNF Cryostat and Cryogenics System. <https://docs.dunescience.org:441/cgi-bin/ShowDocument?docid=602>
- [10] Bettini A et al. 1991 A study of factors affecting the electron lifetime in ultra-pure liquid argon. Nuclear Instruments and Methods in Physics Research A (305 pp 177-186).
- [11] Andrews R et al. 2009 A system to test the effects of materials on the electron drift lifetime in liquid argon and observations on the effect of water. Nuclear Instruments and Methods in Physics Research A (608 pp 251-258).

Acknowledgments

Fermilab is operated by Fermi Research Alliance, LLC under Contract No. DE-AC02-07CH11359 with the United States Department of Energy.