

ADAPTION OF THE HSI-RFQ RF-PROPERTIES TO AN IMPROVED BEAM DYNAMICS LAYOUT

M. Vossberg*, L. Groening, S. Mickat, H. Vormann, C. Xiao
 GSI Helmholtz Center for Heavy Ion Research, Planckstr. 1, Darmstadt, Germany

M. J. Garland, J.B. Lallement, A. Lombardi, V. Bencini
 CERN, Geneva, Switzerland

Abstract

The GSI accelerator facility comprising the linear accelerator UNILAC and the synchrotron SIS18 will be used in future mainly as the injector for the Facility for Anti-Proton and Ion Research (FAIR) being under construction. FAIR requires high beam brilliance and the UNILAC's RFQ electrodes must be upgraded with respect to their beam dynamics design. The new layout is currently being conducted at CERN with the aim of adjusting the electrode voltage according to the design voltage of 123 kV. CST simulations performed at GSI assure that the resonance frequency with the new electrode geometry is recuperated through corrections of the carrier rings. Simulations on the frequency dependence of the rings shapes and their impact on the voltage distribution along the RFQ are presented.

INTRODUCTION

The GSI accelerator facility will not only provide numerous experiments with a variety of ion beams but will be also used in future as an injector for the 'Facility for Anti-Proton and Ion Research' (FAIR), which is currently under construction. In order to meet the requirements of FAIR, beam intensity upgrades to the UNILAC, a UNiversal Linear ACcelerator that can provide up to three different ion species from three independent ion sources at the same time, are necessary. Figure 1 shows the existing GSI (blue) and the extended FAIR facility (red). FAIR will have two injectors, the existing UNILAC and the planned p-Linac. The bottleneck of the UNILAC is the front-end system of the high current injector (HSI) [1]. The present HSI RFQ electrodes have been modified in 2009. The electrode voltage has been increased from 125 kV to 155 kV with the purpose of increasing the acceptance, but the maximum surface field was kept at 31 MV/m by reducing the transverse radius of electrode curvature (ρ), to compensate the higher voltage [2]. The FAIR project requires higher intensities and better beam quality, so after nine years of operation, the used electrodes must be replaced again. Corresponding beam dynamics simulations were conducted at CERN with the aim of adjusting the electrode voltage according to the design voltage of 123 kV. CST simulations are used to verify whether the changed resonance frequency can be compensated by corrections of the carrier rings and the electrode profile.

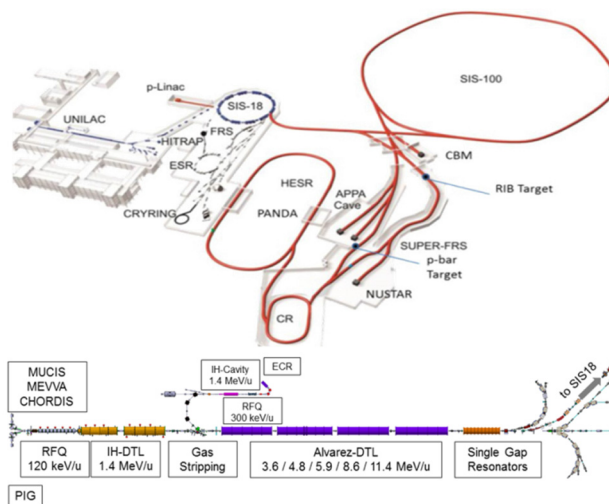

Figure 1: GSI / FAIR facility and the UNILAC injector.

HSI RFQ

The HSI RFQ [3] was designed in 1996 and tested with beam in 1999. In the past years the matching section of the electrodes was redesigned and since 2009 the RFQ was put in operation with the second set of electrodes. This set is currently still in use, the surface is damaged by sparks, especially produced during mixed duty cycle operation with different ion species and high currents. An older set of damaged electrodes is shown in Fig. 2 [4].

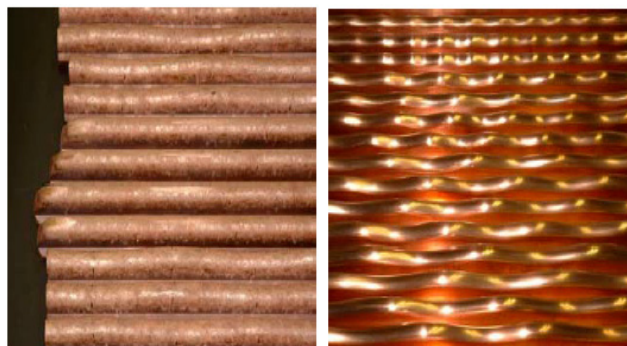

Figure 2: RFQ-electrodes after five years of operation (left) and the set of electrodes (2004) before assembly (right).

A new set of electrodes is being designed and the requirements are shown in Table 1.

Content from this work may be used under the terms of the CC BY 3.0 licence (© 2018). Any distribution of this work must maintain attribution to the author(s), title of the work, publisher, and DOI.

Table 1: Electrode Requirements

reference ion	$^{238}\text{U}^{4+}$
max. input current	20 mA
desired output current	16 mA
length	925 cm
frequency	36.136 MHz
average aperture	5.3 mm – 6 mm
transverse curvature radius	4 mm

The RFQ is designed as a 925 cm long IH cavity. It consists of ten single modules, with ten stems and carrier rings each. Each ring is alternately attached to two opposite electrodes. The rings are not only used to attach the electrodes, but also for frequency matching, because the ring length also has an additional capacity acting on the electrodes. The entire tank should be used again, so exact adjustments to the carrier ring geometry and small changes on the electrode cross section are possible and urgently necessary. Only with accurate simulations it will be possible to determine the carrier ring parameters, in order to achieve the correct frequency and a good flatness distribution along the electrodes [5]. Each module is 92.5 cm long and separately simulated with its special parameters for the length of the carrier ring nose, the electrode base rounding, the angle and the height of the electrode shoulder shown in Fig. 3.

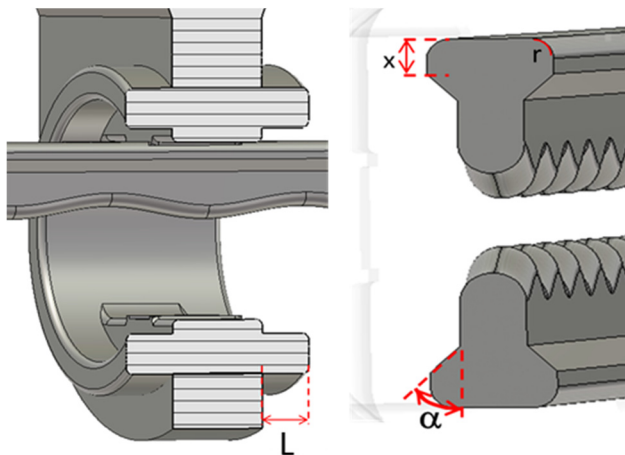

Figure 3: Parameters for the RF simulations: on the left the carrier rings with the length of the ring nose, on the right the changeable parameters of the electrodes.

With the IH-RFQ, adjusting the frequency is not trivial. In total, there are three dynamic tuners that can change the frequency by 45 kHz during operation [6]. There are also five static tuners to adjust the frequency and flatness along the electrodes. It is possible to install up to five additional static tuners. Otherwise, the frequency must be hit by adjusting the carrier ring lengths. Opening the individual tank sections to work on the accelerator structure is not easily possible in comparison to a 4-rod RFQ. Re-fitting the ring lengths requires complete removal of the electrode structure and is thus very time consuming.

RF-SIMULATIONS

All simulations were done with the CST software Microwave Studios [7]. For the simulations, a model with electrode modulation was created as shown in Fig. 4. The individual modules of the 10 m long RFQ were simulated separately. A mesh sweep was used to determine the minimum number of mesh cells needed to minimize the difference between model and real tank simulation.

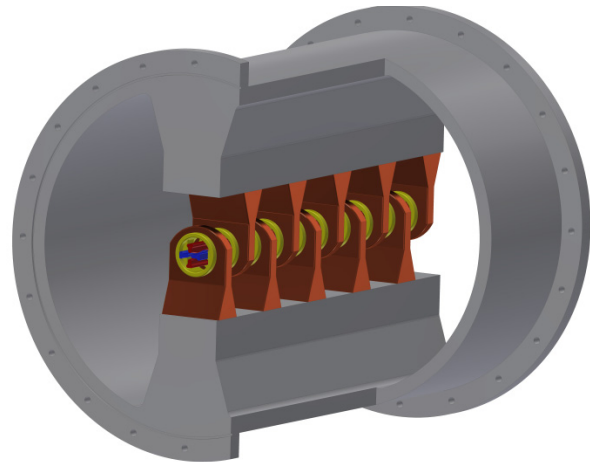

Figure 4: Simulation Model of a single RFQ module with electrode modulation.

The model of the tank with electrodes modulation requires significantly more mesh cells, therefore exact simulations of a long tank section are almost impossible, since these are limited by the computer's RAM. The results were compared with simulations without electrodes modulation, they require less mesh and thus it is possible to simulate longer accelerator structures. The beam dynamic layout of the RFQ electrodes was provided by CERN, but it is still in process. Several preliminary simulations for the RF adaptation were performed with CST MWS. With parameter sweeps those simulations should show the boundary conditions especially for the minimum average aperture and the total length of the RFQ electrodes, so the beam dynamic parameters given by CERN can be cross-checked.

The first results of the simulations showed that the total length of the electrodes should just change minimally, so that the existing tank can be put in operation without additional changes to the geometry. A too large change in length would result in a relatively high capacitance change at the two end sections, which primarily affects the field distribution as well as the frequency. The next step was to examine the allowable aperture of the electrodes. Figure 5 shows that if the aperture is too small one can no longer reach the resonance frequency with variation of the changeable parameters, therefore a minimum aperture of 5.3 mm is assumed.

Content from this work may be used under the terms of the CC BY 3.0 licence (© 2018). Any distribution of this work must maintain attribution to the author(s), title of the work, publisher, and DOI.

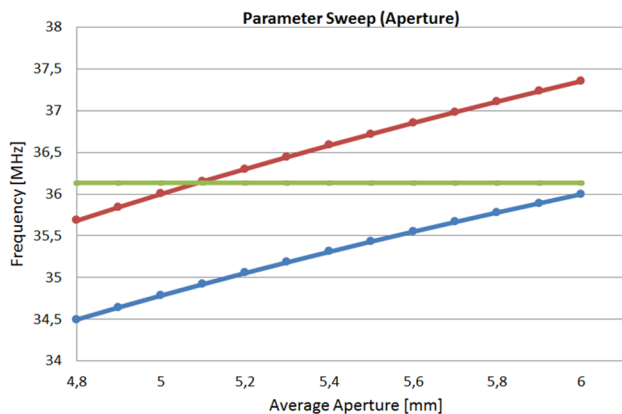

Figure 5: Frequency by changing the averaged aperture. The green line shows the operation frequency, blue / red; frequency from longest / shortest possible carrier ring length.

The transverse radial E-field was studied with preliminary data to check the multipole components in the beam area between the electrodes. Two circular curves were set around the beam axis, shown in Fig. 6. These simulations were performed with the same circular curves and the same z-position for the electrodes with and without modulation.

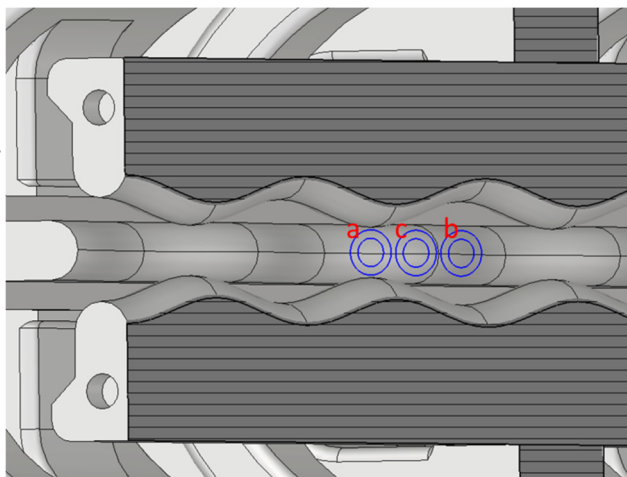

Figure 6: Circular curves between the electrodes with modulation. Position a/b have a min. / max. aperture to the electrodes. Position c is exactly in the middle of the modulation.

The results of the outer curves are shown in Fig. 7. Curve “a” has a minimum aperture to the y-electrode, curve “c” to the x-electrode. Curve “b” has in both cases (with/without modulation) the same distance to the electrodes. The three curves without modulation looks similar, therefore no effects are expected depending on the z-position due to the carrier rings. The interference at the minimum electrode distance will be more closely examined with the final design.

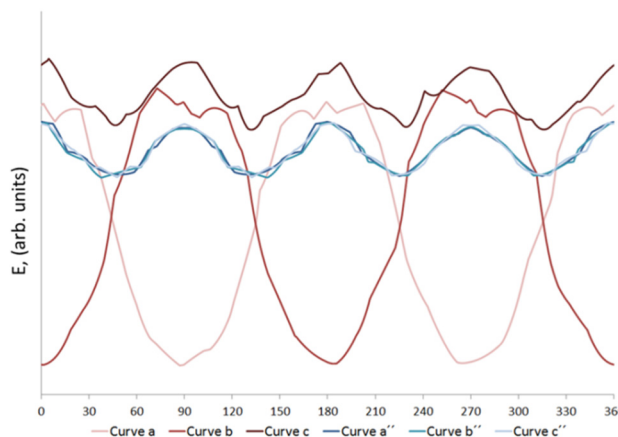

Figure 7: The red curves show the abs. radial E-field between the electrodes. The blue curves the abs. radial E-field between the unmodulated electrodes.

CONCLUSION

Modification of the electrodes and the carrier rings of the HSI RFQ were simulated, to show that RF-requirements can be fulfilled with the beam dynamic design from CERN. Boundary conditions for the average aperture and the total length of the electrodes have been investigated and determined. Simulations with electrode modulation are possible for a certain length of the structure, in comparison with unmodulated electrodes there are only small changes in the RF. For operation with the new electrodes, continuous measurement of the dark current at the electrode should be measured against the time. This could give a statement of the state of the surface. An exchange always requires a lead of time for the development of the new geometry and also a prolonged shutdown for installation.

REFERENCES

- [1] L. Groening *et al.*, “Upgrade of the GSI Universal Linear Accelerator UNILAC for FAIR”, in *Proc. IPAC’16*, Busan, Korea, May 2016, pp. 880-882, doi:10.18429/JACoW-IPAC2016-PAPERID.
- [2] O. Kester *et al.*, “Status of the FAIR Accelerator Facility”, in *Proc. IPAC’14*, Dresden, Germany, Jun. 2014, paper WEPRO060, pp. 2084-2087.
- [3] U. Ratzinger *et al.*, “The new GSI Prestripper Linac for High Current Heavy Ion Beams”, *Proceedings, LINAC 1996*, Geneva, Switzerland.
- [4] W. Barth *et al.*, “Development of the Unilac towards a Megawatt Beam Injector”, in *Proc. 22nd Linear Accelerator Conf. (LINAC’04)*, Lübeck, Germany, Aug. 2004, paper TU103, pp. 246-250.
- [5] M. Baschke *et al.*, “The Final RF Design of the 36 MHz HSI RFQ Upgrade at GSI”, in *Proc. IPAC’17*, Copenhagen, Denmark, May 2017, pp. 1678-1679, doi:10.18429/JACoW-IPAC2017-PAPERID
- [6] CST MicroWave Studio, www.cst.de.
- [7] S. Minaev *et al.*, “Hochfrequenz- und Störkörper-messungen am HSI_RFQ nach Einbau der neuen Elektroden”, unpublished, 2004.