

FIRST BEAM TESTS AT THE CERN SPS OF AN ELECTRO-OPTIC BEAM POSITION MONITOR FOR THE HL-LHC

A. Arteché*, S. E. Bashforth, G. Boorman, A. Bosco, S. M. Gibson,
Royal Holloway, University of London, Egham, UK

N. Chritin, M. Krupa, T. Lefèvre, T. Levens, CERN, Geneva, Switzerland

Abstract

An Electro-Optic Beam Position Monitor is being developed for the High Luminosity Large Hadron Collider (HL-LHC), aimed at the detection of high order proton bunch instabilities and as a diagnostic for crabbed bunch rotation. A prototype EO-BPM was installed in the CERN SPS during 2016 and recent first beam tests of the EO pick-up are presented. The tested system comprises two opposing pick-ups, each equipped with 5 mm cubic LiNbO₃ crystals in vacuum, illuminated by polarized light from a fibre-coupled CW 780 nm laser. The 1 ns proton bunch induces a temporal modulation in the polarization state of light emerging from each birefringent crystal, by the Pockels effect. The modulation is analyzed, then recorded by a fibre-coupled fast photodetector in the counting room. The very first experimental signals obtained by the EO pick-ups of a passing proton bunch are reported as a proof of concept of the idea. Moreover, the expected response of the beam signal is measured with respect to remotely controlled changes in the polarizer and analyser orientations. The data are compared with analytical and electromagnetic simulations. Following the first detection, we report the latest status of the prototype design and future prospects.

MOTIVATION

The crab cavities are one of the main upgrades in the High-Luminosity LHC scenario designed to induce a bunch rotation before and after the interaction point, in order to make the bunches collide head-on and thus maximizing the luminosity [1]. The control of the bunch rotation induced by the crab cavities requires precise diagnostic techniques capable of monitoring intra-bunch transverse position for a 1 ns proton bunch. Whereas the performance of conventional head-tail (HT) monitors is typically limited with a bandwidth of 6 GHz [2], the electro-optic (EO) BPM stands out as a promising innovative candidate aiming to perform with an improved time resolution (<50 ps) due to the faster optical response, expanding the bandwidth up to 10-12 GHz, sufficient for optimizing the crab cavities performance as well as the detection of high order HT instabilities.

Currently the technology is under development and a prototype has been successfully installed at the CERN SPS, where two variants were tested during the 2016 and 2017 SPS runs, respectively [3, 4].

* alberto.arteché.2014@live.rhul.ac.uk

ELECTRO-OPTIC PICK-UP PROTOTYPE

The EO pick-up prototype includes button-like devices that comprise a compact optical system formed of a LiNbO₃ (LNB) crystal sample and two prisms in combination with an optical beam (OB) [5]. Figure 1 depicts the design with the optical path superimposed for both prototype variants, zero and one: the 10 mm side right-angle prisms align the laser beam propagating in free-space through the crystal and back-reflect it out of the pick-up. The button body is shielded by a flange and a viewport that permits the transmission of the OB in and out of the optical system embedded in the vacuum.

The key piece of the EO pick-up is the LNB sample assembled in the core of the opto-mechanical body. The fundamental principle of detection exploits the Pockels effect exhibited by the LNB crystals, since its birefringence is modified by the action of the Coulomb field propagating from a passing particle bunch. The system imitates an EO amplitude modulator where the initial linear polarization at 45° is rapidly modified at the emerging beam by the action of the field on the crystal [6]. The extent of the optical modulation depends on the field strength and the crystal length. The output beam is incident upon an analyser which measures this modulation. Therefore, the transverse displacement can be obtained in the same fashion as the traditional BPM layouts, taking the difference in optical response between pick-ups on the opposite sides of the beam pipe.

The prototype pick-up variants differ when comparing the dimensions of the crystal and the use of electrodes. For pick-up zero, the propagating Coulomb field decays sharply at the crystal interface due to the LNB dielectric constant $\epsilon_{33} = \epsilon_z = 30$ in the propagating direction z [4, 7]. The field strength limitation caused by the dielectric constant can be partially overcome by placing electrodes to direct more field lines towards the crystal, following the mechanism shown in Figure 1. According to the CST simulations [8] carried out for each case using SPS nominal bunch of length $4\sigma=1$ ns and intensity of 1.15×10^{11} protons, the estimated electric field in the crystal for pick-up zero is 0.65 kV/m whereas the field strength for pick-up one will be enhanced up to 2.8 kV/m. Furthermore, given the same field the optical modulation is enlarged by a factor 1.8 for pick-up one as it holds a 9 mm long crystal while pick-up zero employs a cubic 5 mm sample. Consequently, the overall effect of the crystal elongation in combination with the field increase predicts an EO signal ~8 times higher for pick-up one with respect the first proposal pick-up zero for the same nominal bunch conditions [6].

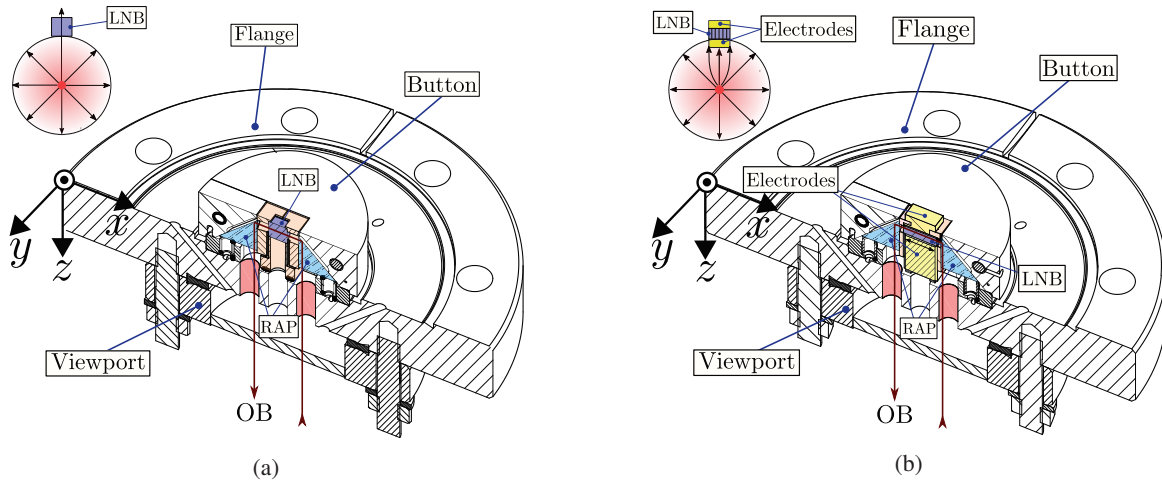

Figure 1: Prototyp pick-up variants: zero (a) with only a crystal; and one (b) with an additional electrode.

EXPERIMENTAL SETUP

Optical Setup

The light source is a 780 nm laser that provides a < 200 kHz linewidth OB that is vertically polarized. The fibre-coupled output is split and connected to two PM fibres that carry the OB from the instrumentation room to the location where both prototypes are installed on the SPS ring, as in Figure 2.

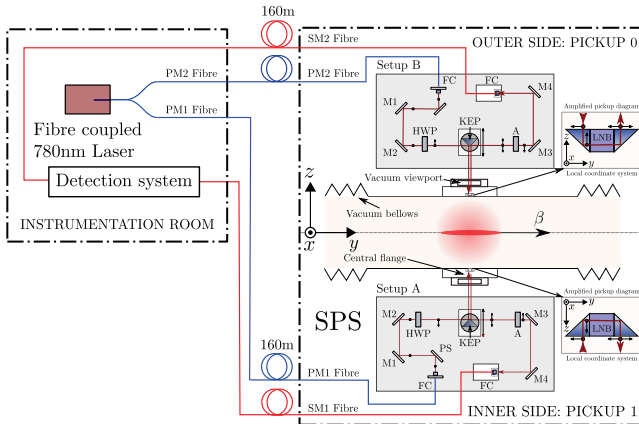

Figure 2: Diagram of the optical setup.

At the other extreme of each PM fibre, the OB is delivered vertically polarized by a 6.24 mm focus distance fibre collimator (FC). Furthermore, the vertical polarization is filtered by a polarizing plate splitter (PS). Two mirrors M1 and M2 are used to align the optical path correctly towards a knife-edge prism (KEP), which reflects the beam trajectory by 90° into the EO pick-up. The OB returned via the EO pick-up is steered towards a remote controlled 3-D stage with the assistance of mirrors M3 and M4. The beam is coupled back into a single mode (SM) return fibre held by a 3-D stage that transports the light 160 m back to the detection system, housed in the same instrumentation room as the laser. Since the setup must emulate an optical modulator configuration, a half-wave plate (HWP) and an analyser are placed before

and after the KEP respectively. Furthermore, both HWP and analyser are held by rotation stages connected to a PC in the instrumentation room to permit remote control of the initial input polarization, as well as the analyser orientation.

There are two optically symmetric setups adjacent to each EO pick-up in the horizontal plane. The two pick-ups mounted on the outer and inner sides of the SPS ring are variants zero and one, respectively.

Preliminary Detection System

Since LNB is a naturally birefringent crystal, the initial polarization is modified in the absence of any passing bunch. Therefore, a certain amount of light power is transmitted through the analyser and carried by the return fibre that is coupled to a fast detector in the instrumentation room. A preliminary detection scheme was set up with a relatively low bandwidth amplifier that was available for the initial tests described here. The DC bias monitor output V_{DC} of the detector monitors the average input light power, whereas the RF output provides the EO signal from the return fibre which is induced when a proton bunch is passing. The signal at the RF output V_{RF} is magnified by an effective gain G_e due to a 210 MHz amplifier. Finally, both DC bias monitor and RF signal readouts are recorded by a 12-bit oscilloscope. Figure 3 depicts the entire chain of signal detection that separates the baseline and transforms an optical power signal into a voltage signal.

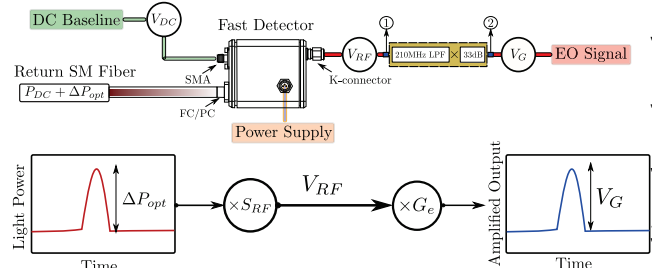

Figure 3: Preliminary detection chain scheme.

PICK-UP 0: FIRST ELECTRO-OPTIC SIGNAL

Prototype pick-up zero on the outer side of the CERN SPS ring was used to carry out the first tests that culminated in the very first electro-optic detection of a proton beam in December, 2016. The measurements were taken parasitically during the AWAKE experiment run in the SPS, which provided an average bunch length of $4\sigma=1.8$ ns and a bunch charge of between 1.5×10^{11} and 3.5×10^{11} protons.

In these very first studies, the aim was to observe a signal corresponding to the Coulomb field of the passing bunch interacting in the electro-optic crystal, as a modulation of the light intensity through the system. For clarity, single shot measurements were not performed, rather, an average optical signal was recorded during multiple revolutions of an AWAKE bunch within a CERN SPS cycle.

According to the numeric simulations for these parameters, the Coulomb field penetrating the crystal E_{LNB} is much lower than E_π for the 5 mm LNB sample integrated in pick-up zero, e.g. $E_{LNB} \approx 1$ kV/m $\ll E_\pi = 711$ kV/m, for a bunch formed of 3.0×10^{11} protons bunch. In these conditions the signal sensitivity is strongly dependent on the crystal output polarization, which is determined by the natural birefringence. The sensitivity is maximum for circular polarization and it will have no sensitivity for linear polarization [6]. The fit curve of the detector DC bias monitor output taken as a function of the analyser position is shown in Figure 4a, which represents an anticlockwise scan of the polarization state projection depicted on the bottom right. The measured elliptical polarization value leads to a sensitivity of 90% of the maximum during signal acquisition.

A fast electro-optically induced signal peak, corresponding to the proton bunch was observed using pick-up 0. The electro-optic signal is presented in Figure 4b for different positions of the transmission direction (TD) of the analyser, from vertical at 90° to 210° keeping a constant input linear polarization at 45° into the crystal. Due to the preliminary configuration of the pick-up and detection scheme, the Signal-to-Noise Ratio (SNR) was low, so it was necessary to average over the entire AWAKE cycle (digitizing ~ 600 turns) to achieve detection. Therefore, the simulated optical power modulation ΔP_{opt} was scaled accordingly with the average bunch length and charge of each cycle, as well as considering the crystal experimental output polarization. The dashed blue line represents the estimated peak voltage signal V_G obtained from applying the detection chain to the expected power signal assuming a PD response S_{RF} of -148 V/W scaled to the working wavelength 780 nm, and also an effective gain of 27 dB in the amplifier that corresponds to the typical AWAKE bunch length mentioned previously.

In a crossed polarizers scenario when the analyser is at 135° , the EO signal is expected to be maximum; on the contrary, when the analyser position is placed either vertical (90°) or horizontal (180°), the optical modulation will be undetectable. In the intermediate cases the signal decays or enhances accordingly. Since the detector has negative

response, a positive signal indicates that the polarization projection is decreasing when the beam is passing, and equivalently, the sign is swapping from positive to negative when the analyser is reading the projection reduced due to the passing bunch. For the set of measurements presented in this paper, the projection along the analyser position parallel to 135° is squeezed while the perpendicular direction at 225° (45°) is elongated.

In conclusion, the first electro-optic signal of a proton beam has been observed and the signal peak is found to change sign in accordance with the electro-optic theory. Additionally, the signal level estimations agree with the numeric-analytic simulations well within an order of magnitude, even before any optimization of the preliminary pick-up design and detection scheme.

PICK-UP 1: POSITION SENSITIVITY

Even after significant amplification and considerable averaging, the Signal-to-Noise Ratio (SNR) of both prototypes was too poor to directly observe the pick-up's sensitivity to the transverse beam position. Recent measurements prove that the unfavourable SNR is a consequence of the photodetector's noise floor. Future direct measurements of the pick-up's beam position sensitivity will require a significant improvement of the photodetection network.

Nevertheless, the beam position correlation of the EO pick-up's signal was indirectly observed by measuring the narrow-band frequency spectrum around one of the higher harmonics of the SPS revolution frequency. The measurements were carried out with a single bunch of about 2×10^{10} protons stored in the SPS ring at the energy of 270 GeV for several hours during a so-called "coasting beam" operation.

The coasting beam conditions were very favourable for measurements of the EO pick-up. As the beam is stored at a constant energy, the pick-up's output signal can be averaged over a long time which reduces the noise. Moreover, due to constant revolution frequency, synchronous detection techniques can be applied which leads to further SNR improvement. In total, the coasting beam measurements were conducted with a noise floor of -100 dBm which translates to some $2 \mu\text{V}_{\text{RMS}}$ across a 50Ω load.

Figure 5 shows the frequency spectrum of the EO pick-up's output acquired around the 39.992 MHz component which was the 922nd harmonic of the 43.375 kHz revolution frequency. The peak at the central frequency is surrounded on either side by two sharp peaks: at ± 6 and ± 8 kHz. These frequencies correspond to, respectively, 0.138 and 0.184 fractions of the revolution frequency:

$$\frac{6}{43.375} = 0.138 \quad \frac{8}{43.375} = 0.184$$

The nominal horizontal and vertical betatron tunes in the SPS are $Q_h = 0.13$ and $Q_v = 0.18$. For position dependent sensors, these tunes constitute themselves as sidebands around the n-th revolution frequency harmonic [9]:

$$f_{Q_n} = n \times f_{\text{rev}} \pm Q \times f_{\text{rev}}$$

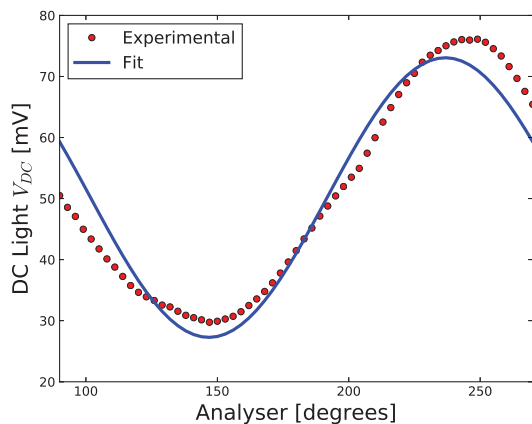

(a)

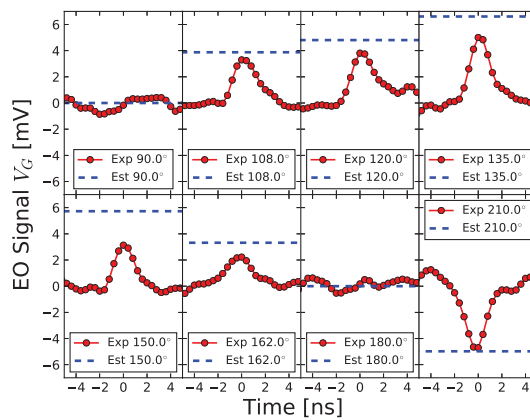

(b)

Figure 4: Analyser polarization scan of pick-up zero (a) and EO Signal for different analyser positions (b).

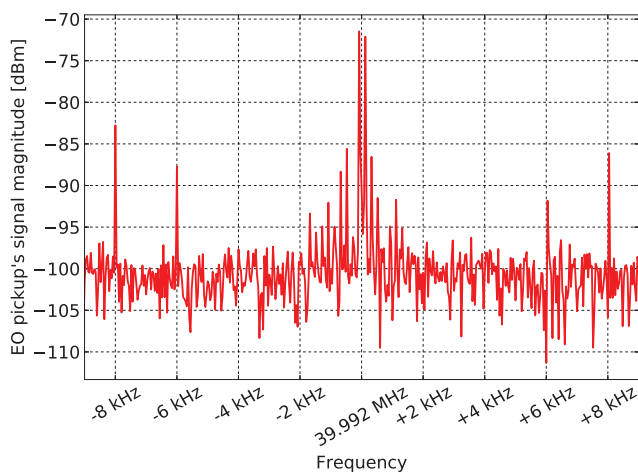

Figure 5: Frequency spectrum of the EO pick-up's signal around the 922nd harmonic of the SPS revolution frequency.

As the tunes in the SPS drift from their nominal values during the coasting beam operation, it is fair to conclude that the sideband peaks around the 922nd revolution frequency harmonic shown in Fig. 5 correspond to the vertical and horizontal SPS tunes during the measurements. This, in turn, proves that the EO pick-up is sensitive to the transverse beam position.

SUMMARY AND FUTURE WORK

The tests for the first two electro-optic pick-ups on the SPS have been presented in this paper. The signal observed from pick-up zero demonstrates a proof of concept that the electro-optic modulation induced by a passing proton bunch responds as expected from electromagnetic and analytic simulations. A modified pick-up design, including a beam facing electrode to shape the field, was found to enhance the signal by a factor ~ 8 .

Even though the SNR with the preliminary system was low, indirect measurements of the vertical and horizontal betatron tunes were taken with a spectrum analyser, which

demonstrate that the device is sensitive to transverse position. To further improve the signal it is necessary to refine the pickup design, such that the induced field strength E_{LNB} is increased to a magnitude similar to the E_{π} of the crystal. Two areas for future improvement include: modifying the electrode geometry to increase the field density; and lengthening the crystal. Simulations have shown that the synergy of both effects result in a significant signal enhancement.

ACKNOWLEDGEMENTS

We thank the CERN vacuum group, the CERN mechanical and materials engineering group, and the SPS operation team for their support. Work funded by UK STFC grant ST/N001583/1, JAI at Royal Holloway University of London and CERN.

REFERENCES

- [1] Y. Miyahara, *NIM. Phys. Res. A* 588 (2008) 323–329.
- [2] R. Steinhagen et al., “A Multiband-Instability-Monitor for High-Frequency intra-bunch Beam Diagnostics”, TUBL3, Proc. of IBIC 2013, Oxford, UK.
- [3] S. M. Gibson et al., “High frequency electro-optic beam position monitors for intra-bunch diagnostics at the LHC”, WEDLA02, Proc. of IBIC 2015, Melbourne, Australia.
- [4] A. Arteche et al., “Development of a prototype electro-optic beam position monitor at the CERN SPS”, WEPG09, Proc. of IBIC 2016, Barcelona, Spain.
- [5] P. Y. Darmedru, “*Conception mécanique d'un instrument de mesure de position d'un faisceau de particules*”, CERN EN report, Groupe 2A04, 2015.
- [6] A. Yariv P. Yeh, “*Optical waves in crystals*”, pp. 241–243, pp. 282–283.
- [7] R. S. Weis and T. K. Gaylord, *Appl. Phys.* A37 191–203 (1985).
- [8] Computer Simulation Technology, <http://www.cst.com>
- [9] M. Gasior and R. Jones, “The principle and first results of betatron tune measurement by direct diode detection”, LHC Project Report 853, 2005, CERN, Geneva, Switzerland