

COMMISSIONING OF THE OPERATIONAL LASER EMITTANCE MONITORS FOR LINAC4 AT CERN

T. Hofmann*, G.E. Boorman, A. Bosco, S.M. Gibson

John Adams Institute at Royal Holloway, University of London, Egham, TW20 0EX, United Kingdom
 F. Roncarolo, CERN, Geneva, Switzerland

Abstract

A laser-based emittance monitor has been developed to non-invasively measure the transverse emittance of the LINAC4 H^- beam at its top energy of 160MeV. After testing several sub-systems of the instrument during linac commissioning at intermediate energies, two instruments are now permanently installed. These instruments use a pulsed laser beam delivered to the accelerator tunnel by optical fibres before final focusing onto the H^- beam. The photons in the laser pulse detach electrons from the H^- ions, which can then be deflected into an electron multiplier. In addition, the resulting neutral H^0 atoms can be separated from the main beam by a dipole magnet before being recorded by downstream diamond strip-detectors. By scanning the laser in the horizontal and vertical plane the beam profiles are obtained from the electron signals and the emittance can be reconstructed by the H^0 profiles at the diamond detectors. This paper describes the final system layout that consists of two independent instruments, each measuring profile and emittance of the H^- beam in the horizontal and vertical plane and discusses the preliminary commissioning results.

gence to be determined and consequently, in combination with the laser position, the H^- emittance to be reconstructed, in a similar way as with the classical slit-grid method.

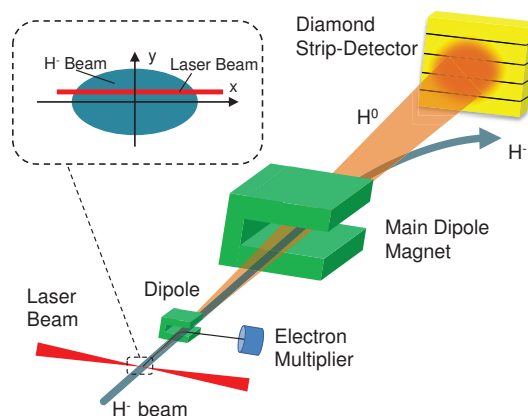

Figure 1: Concept for combined vertical profile and emittance measurement. To sample the horizontal plane the laser beam and diamond strip-detector must be turned by 90° .

INTRODUCTION

LINAC4 has accomplished multiple commissioning steps and is now in its reliability run before being connected to the PS-Booster in 2019/2020. During the machine commissioning, a laser emittance monitor has been developed to measure non-destructively the transverse beam profiles and emittances. Different prototypes have been tested at beam energies of 3 MeV [1], 12 MeV [2] and 50/80/107 MeV [3] to verify the performance of the system and measure beam profiles and emittances. A summary of the prototype development and the associated results can be found in [4] and [5].

In Fig. 1 the concept of the instrument is shown. A laser beam is focused on the H^- ion beam such that it exhibits a near constant diameter at the interaction region with a size of 0.14 mm compared to the 4.8 mm (4σ) size of the H^- ion beam. Electrons are detached from the H^- ions, deflected by a weak dipole field and subsequently detected with an electron multiplier. The created H^0 beamlets drift unaffected through a downstream main dipole and is recorded with a diamond strip-detector. By scanning the laser beam across the H^- beam the transverse profile can be obtained from the signal of the electron multiplier. The H^0 beamlet profiles measured with the diamond detector allow the beam diver-

SYSTEM DESIGN

Figure 2 shows the 160 MeV region at LINAC4, where two laser emittance monitors have been installed to measure the transverse emittances and thus ensure that the requirements for PS-Booster injection are met. The first in-

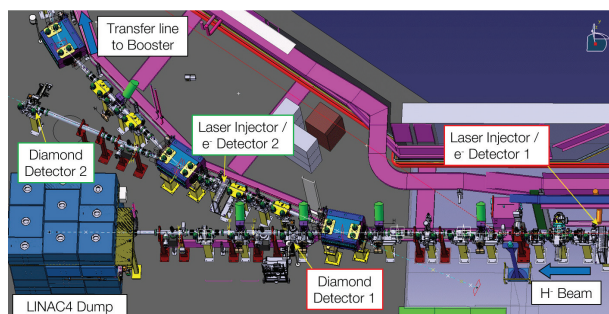

Figure 2: Overview of the two installed instruments in the 160 MeV region of LINAC4.

strument is installed in the straight line towards the main dump where emittance measurements without dispersion perturbations are possible. The second instrument is located between two dipole magnets, which therefore profits from a

* thomas.hofmann@cern.ch



Content from this work may be used under the terms of the CC BY 3.0 licence (© 2018). Any distribution of this work must maintain attribution to the author(s), title of the work, publisher, and DOI.

low H^0 background level. However a dispersion correction must be taken into account for the emittance reconstruction.

Each instrument consists of a laser injector, electron detector setup as shown in Fig. 3 and a diamond detector setup as shown in Fig. 4. In the laser hutch, located in a service area about 12 m above the accelerator zone, a laser source supplies four optical fibres such that pulsed laser beams ($\lambda = 1064$ nm; $M^2 < 1.3$; $t_{pulse} = 100$ ns; $f_{pulse} = 250$ kHz; $P_{peak} = 150$ W) are delivered to both laser injectors for x - and y -scan. As the fibres for the y -scan are 46 m longer than the fibres for x -scan of the H^- beam, a delay of 223 ns separates the two laser pulses and thus allows quasi simultaneous measurements in both planes. Moving the fibre out of the scan range of the ion beam the laser beam can be redirected to a diagnostic line for M^2 and absolute pulse energy measurements (see laser beam from y -stage in Fig. 3).

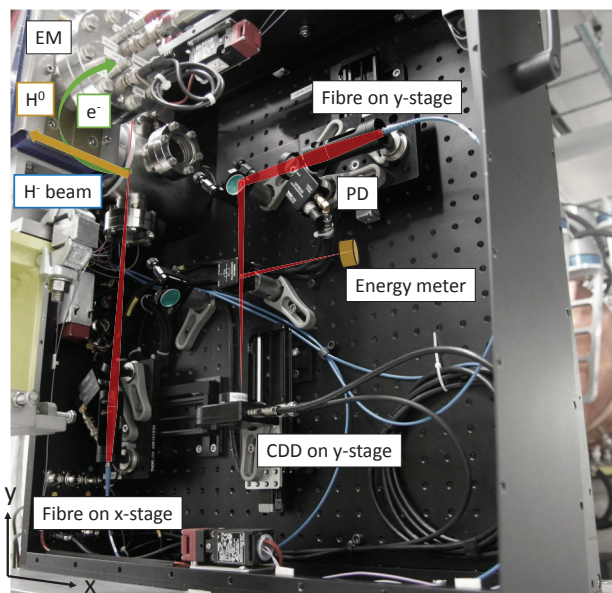

Figure 3: Laser injector for x - and y -scan of the H^- beam including the laser diagnostic line (y -beam entering diagnostic line in this picture). The downstream dipole magnet deflects electrons into the electron multiplier (EM).

The specifications of the electron multiplier (Hamamatsu RS2362 - [7]) are shown in Table 1. The negative bias voltage (-2.7 kV) is split linearly over a cascade of 23 dynodes. Each dynode consists of a coarse copper mesh coated with beryllium oxide (BeO). When photo-detached electrons hit the first dynode (DY1), the BeO coating emits electrons, which are directed towards the second dynode due to the applied bias and subsequently an electron avalanche builds up. This detector setup features an overall gain of 10^6 and a rise-time of 3.5 ns. A detailed description of the laser and electron detection setup can be found in [5].

The H^0 strip-detector setup shown in Fig. 4 is based on poly-crystalline (pCVD) diamond material to minimise the degradation through radiation damage [6]. The 500 μ m

Table 1: Characteristics of the Electron Multiplier [7, 8]

Parameter	Value
EM Type	Coarse Mesh
Number of dynodes	23
Dynode material	Cu-BeO
Dynode capacitance	23 pF
Input aperture diameter	20 mm
Bias voltage typ.	-2700 V
Gain typ.	10^6
Rise time	3.5 ns
Dark current	5 pA

thick diamond discs exhibit 20 x 20 mm or 32 x 10 mm transverse dimensions as a function of the expected H^0 beamlet size for each of the four locations. Each detector provides 28 channels with strip pitches between 323 μ m and 680 μ m. The horizontal and vertical actuators hosting the diamond detectors are placed one behind the other in the beam direction such that they can simultaneously move into the beam pipe and measure the H^0 beamlets resulting from horizontal and vertical laser beam interactions. As the distance between both detectors in beam direction is just 8 mm, the induced blur due to multiple scattering in the upstream detector will not lead to a degradation of the resolution of the downstream detector. The detector signals are pre-amplified and subsequently transferred to a real-time DAQ system with 50 MS/s ADC input.

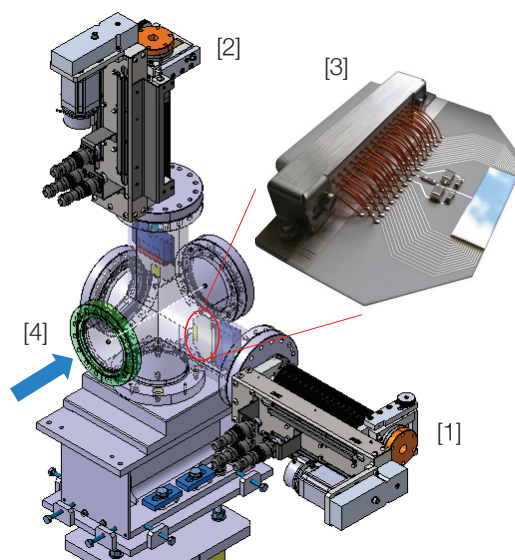

Figure 4: H^0 detection vacuum vessel with horizontal [1] and vertical [2] actuators to move the diamond strip-detectors [3] into the beampipe to record the H^0 beamlets [4].

PROFILE MEASUREMENTS WITH ELECTRONS

During the 160 MeV beam commissioning at LINAC4 the H^- beam was predominantly sent to the main dump such that only profile measurements with the electron multiplier could be accomplished.

In Fig. 5 the raw signal of the electron multiplier is compared to the photo-diode (PD) signals of both laser-beams (x, y). The EM signal corresponds clearly to the two 100 ns long laser-pulses, separated by 223 ns. The tails observed on the PD signals come from their response and do not represent the actual shape of the laser pulse. This can be seen from the EM measurement that shows a sharp rise and fall signal corresponding to the x - and y -plane laser pulse. There is therefore very little cross-talk between the x - and y -plane measurements. The EM signal exhibits a higher than expected noise level which is attributed to many contributions such as background electrons, electromagnetic interference, electronic mismatching before the ADC and instabilities in the detector response. One of our next tasks will be to investigate in detail these perturbations to enhance the accuracy of the instrument.

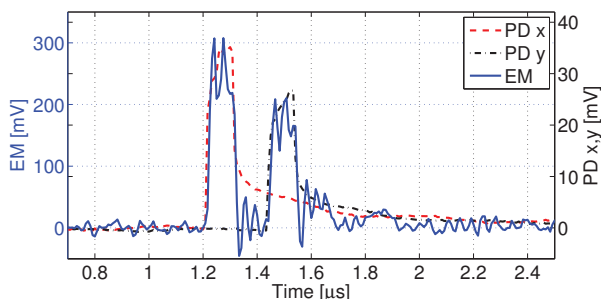

Figure 5: Signal of electron multiplier (EM) and photodiodes of horizontal and vertical laser beam (see PD in Fig. 3).

By scanning the two laser beams across the H^- beam and integrating the two electron multiplier signals for each position, the beam profiles in both planes are obtained. Figure 6 shows the very first measured horizontal and vertical beam profiles at 160 MeV, compared to the ones obtained by a downstream wire scanner (scaled according to the beam optics between the two instruments). The agreement in terms of beam shape is very good and the measured beam size difference is 14% in the x -plane and 2% in the y -plane. This first set of measurements allowed precise tuning of the steerer magnet deflecting the electrons, something that was found to be essential to optimise in order to obtain accurate results.

CONCLUSION

Two instruments to measure non-destructively the transverse beam profiles and emittances have been installed in the LINAC4 160 MeV region. After the laser system was characterised and stable operation was achieved, the

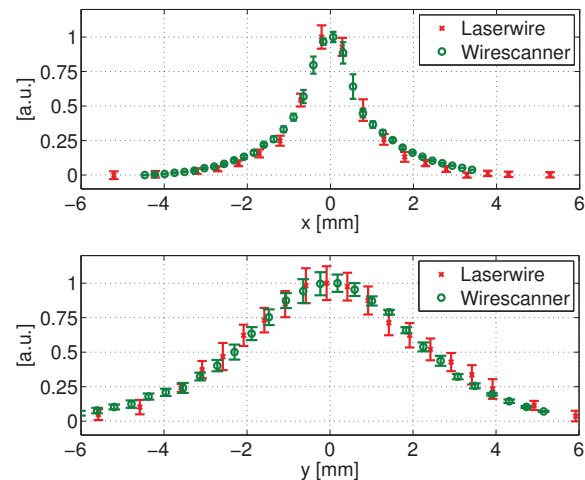

Figure 6: Beam profiles recorded with the laserwire and a wire-scanner in both planes. As the wire scanner is located 2.7 m downstream of the laserwire, its profile is scaled according to the beta-function ratio of both locations.

commissioning was mainly focused on profile measurements by electron detection where simultaneous measurements of the horizontal and vertical plane were conducted. By analysing the EM signal, it was verified that there is little cross-talk between both planes. Scanning the laser power and recording the electron signal, the linear response of the electron multiplier was confirmed. The preliminary profile results agree well with wires scanner measurements. The EM signal noise level, higher than expected, will be studied for implementation of improvements during 2018.

The diamond detectors for H^0 detection have been characterised with a β -source in the laboratory and installed in the vacuum vessel. Due to the very limited time where the beam was directed towards the PS-Booster transfer line, no systematic measurements with the diamond detectors for emittance reconstruction could be completed so far. However, during preliminary tests, pulses similar to the ones in Fig. 5 have been observed on the diamond detector channels, which indicates that the detectors are ready for operation.

During 2018 the diamond detectors will be fully commissioned in order to deliver an operational emittance monitor. To assess the system accuracy, it is foreseen to compare the laser emittance meter results to more conventional techniques like the 3-profile-method or quadrupole scans.

ACKNOWLEDGEMENTS

We would like to thank our colleagues in the CERN BE-BI-PM section and the LINAC4 commissioning and operation teams for their strong support. Furthermore, we are grateful for a fruitful collaboration with CERN TE-MSC group for the redesign and commissioning of the steerer magnets.

REFERENCES

- [1] T. Hofmann et al, "Demonstration of a Laserwire Emittance Scanner for the CERN LINAC4 H⁻ Beam", Phys. Rev. ST, Accelerators and Beams 18, 122801 (2015).
- [2] T. Hofmann et al, "Experimental results of the laserwire emittance scanner for LINAC4 at CERN", Nucl. Instrum. Methods A 830C (2016): 526-531.
- [3] S. Gibson et al, "Experimental results of a compact laserwire system for non-invasive H⁻ beam profile measurements at CERN's LINAC4", TUF77, Proceedings of IBIC16 , Barcelona, Spain.
- [4] T. Hofmann et al, "Results From the laserwire Emittance Scanner and Profile Monitor at CERN's Linac4", Proceedings of LINAC16, East-Lansing, MI, USA.
- [5] T. Hofmann, "Development of a Laser-based Emittance Monitor for Negative Hydrogen Beams", PhD thesis, University of Erlangen-Nuremberg, Germany, 2017.
- [6] W. de Boer et al, "Radiation hardness of diamond and silicon sensors compared", Phys. Status Solidi A 9(204), (2007): 3004-3010.
- [7] Hamamatsu Photonics K.K., "Electron Multipliers", 2015.
- [8] Hamamatsu Photonics K.K., "Photomultiplier Tubes - Basics and Applications", 2006.