

PERFORMANCE OF LINAC-4 INSTRUMENTATION DURING COMMISSIONING

U. Raich, CERN, Geneva, Switzerland

Abstract

Linac-4 is CERN’s new H⁻ Linac, which will replace the aging Linac-2 proton machine. Linac-4 is being built and commissioned in stages. While the machine is permanently equipped with the standard beam instrumentation necessary to ensure smooth operation, three dedicated measurement benches have also been designed to commission the source and LEBT at 45 keV, the MEBT and its chopper at 3 MeV as well as the first DTL tank at 12 MeV and finally the full DTL at 50 MeV and CCDTL at 100 MeV. The beam after the PIMS structures at the Linac’s full energy of 160 MeV will be sent to a beam dump and commissioned with permanently installed instruments. Installation and commissioning of the machine up to the CCDTL is now complete. This contribution will present the results from the various commissioning stages, showing the performance of the various diagnostic devices used and comparing the data obtained to simulations.

ION SOURCE AND LEBT

Beam diagnostic devices measure the total beam current coming from the source with a Faraday Cup and a Beam Current Transformer (BCT) and the transverse beam distribution with a sandwich of horizontal and vertical wire grids.

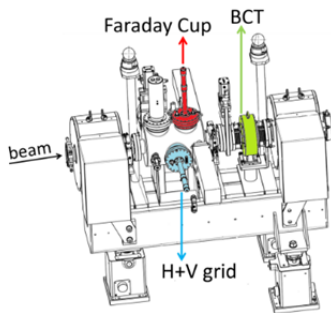

Figure 1: LEBT instrumentation.

As discussed below, the grid signal is dominated by the H⁻ ion net charge deposition (negative) on the wires. Both the metallic wire frame and the wires themselves can be polarized in order to suppress secondary emission and repel low energy electrons emerging from the source.

The wire readout system allows signal sampling at 250 kHz such that the signals on the wires can be compared to the Faraday Cup signal.

As the 45 keV proton is stopped in the wire with a secondary emission yield estimated as ~ 3.5 charges per ion, a positive signal with the same overall shape as the negative Faraday Cup signal is expected. However, what was observed was the black trace in Figure 2.

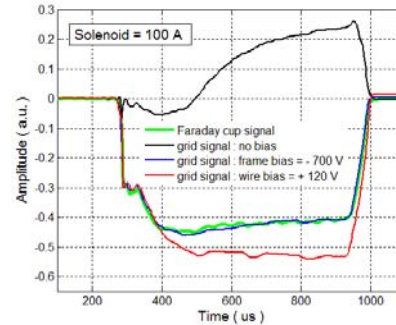

Figure 2: Comparison wire signal to Faraday Cup.

This can be understood as suppression of the secondary emission by strong space charge effects coming from the primary H⁻ beam. When negatively polarizing the wire frame the secondary emission can be further suppressed such that the wire grid works only in charge collection mode and its wire signals (blue) are now negative, following the Faraday Cup signal (green). Polarizing the wires positively has the same effect but attracts additional background electron such that the signal is distorted (red).

In addition to the permanent instrumentation, the LEBT was temporarily equipped with a slit/grid emittance meter moved to various positions along the LEBT to verify the matching to the RFQ acceptance.

THE MEBT OR CHOPPER LINE

The MEBT adapts the 3 MeV H⁻ beam coming from the RFQ to the first cavity of the DTL Linac and implements a fast chopper to adapt the beam longitudinally for injection into the PS Booster. It contains two BCTs, which, in combination with the LEBT BCT, allows the transmission through the RFQ and chopper to be determined. It also contains two L-shaped wire scanners for transverse profile measurement [1].

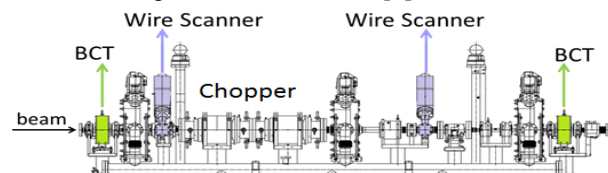

Figure 3: MEBT layout.

The correct functioning of the chopper was first verified with the vertical wire scanner observing the vertical beam deflection when the chopper is switched on, as shown in Figure. 4.

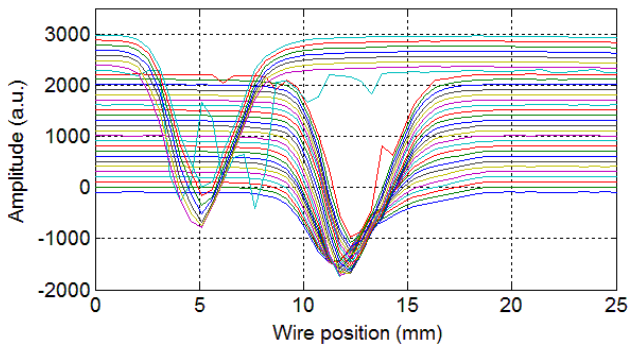

Figure 4: Wire profiles with chopper switched on.

The rise and fall times of the chopper were observed with the MEBT's second BCT, whose electronics can sample the BCT signal with a maximum sampling frequency of 100 MHz. Rise and fall times of less than 10 ns were observed.

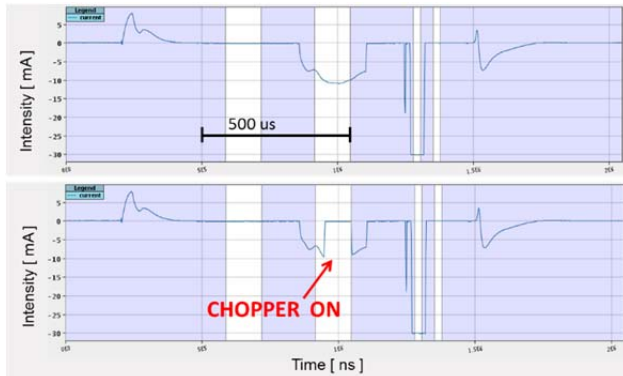

Figure 5: Chopped beam signal seen on transformer (Top—chopper OFF, Bottom: Chopper ON).

THE 3/12 MeV MEASUREMENT BENCH

To fully characterize the beam after the RFQ at 3 MeV and after the first DTL tank at 12 MeV a dedicated temporary measurement bench was designed. It contained

- 2 BCTs
- 3 Beam Position Monitors (BPMs)
- 1 slit/grid emittance meter
- 1 laser emittance meter with diamond detector
- 1 spectrometer magnet and horizontal wire grid
- 1 bunch shape monitor (BSM)

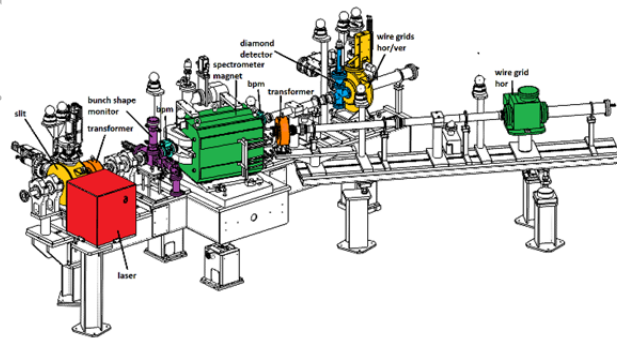

Figure 6: 3/12 MeV measurement bench.

Emittance Meter

In contrast to the LEBT emittance meter the design of the 3/12MeV emittance meter slit was very delicate because of the high thermal load expected on the slit material for a beam of up to 70 mA at 12MeV. A harmonica type design, distributing the heat load onto a larger surface and using carbon on a water cooled copper support was used. Nevertheless it was necessary to limit the pulse length to 100 μs compared to the nominal 400 μs.

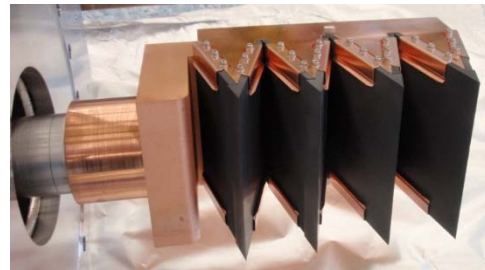

Figure 7: Emittance meter slit design.

The wire grids use carbon wires both due to its high sublimation temperature and since this gave the maximum signal level after considering the competing effects of charge collection and secondary emission. If the beam pulse gets longer than ~ 200 μs thermionic emission is observed to destroy the beam signal [2].

The results from the phase space scans for nominal optics show very good agreement with the expected matched phase space parameters as can be seen in Figure 8 [3].

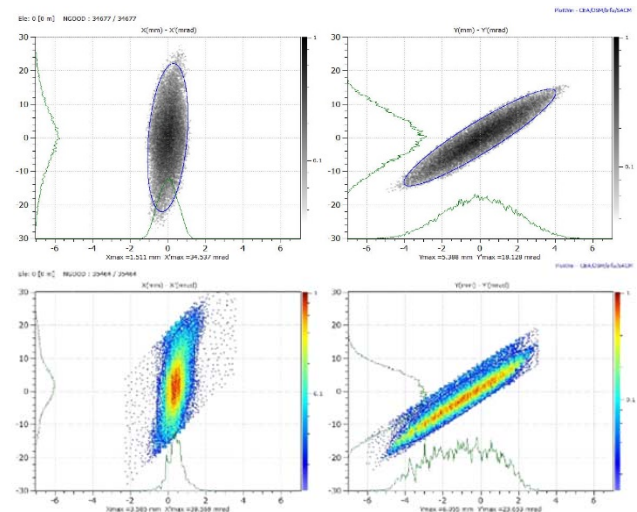

Figure 8: Black: expected matched beam, coloured: measured matched beam.

In addition to the traditional slit/grid device a laser emittance scanner was also employed. A thin laser beam is used to neutralize part of the H⁻ ions converting them into H⁰ atoms [4]. A spectrometer magnet is used to separate the H⁻ ions from the H⁰ atoms. Moving the laser through the beam and measuring the angular distribution of the H⁰ atoms for each laser position allows the phase

space to be scanned in a similar fashion to the slit/grid emittance meter (Figure 9).

Comparisons between the two methods show perfect agreement (Figure 10). The laser emittance meter has the advantage of not relying on any material to intercept the beam and can therefore also be used at high energy and during physics production.

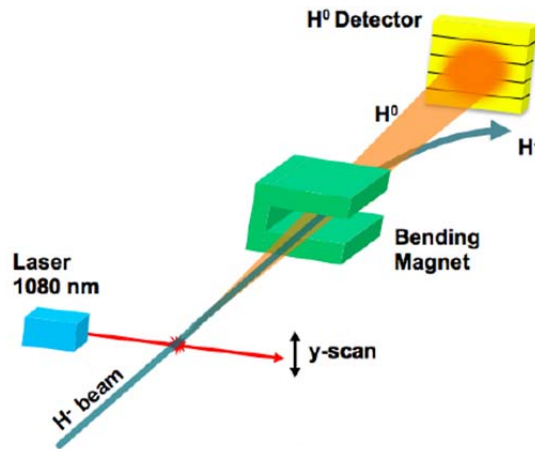

Figure 9: Emittance measurement using the laser wire.

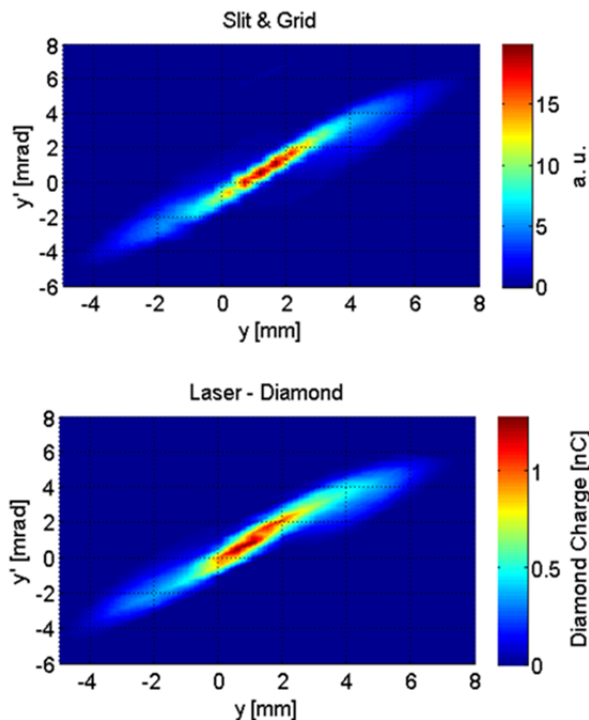

Figure 10: Emittance measurement slit/grid and laser.

Bunch Shape Measurements

The longitudinal charge distribution can be measured with a Bunch Shape Monitor (BSM) build by the Institute for Nuclear Research (INR), Troitsk, Russia. The instrument has a temporal resolution of ~ 8 ps and can measure the longitudinal shape of the micro-bunches every $1 \mu s$ along the $400 \mu s$ beam pulse. It was used on

both the 3/12MeV and 50/100 MeV measurement benches to adjust the RF parameters of the cavities (buncher cavity and accelerating cavities) and will be definitively installed at the end of the complete linac in the transfer line to the PS-Booster. A typical measurement result is shown in Figure 11.

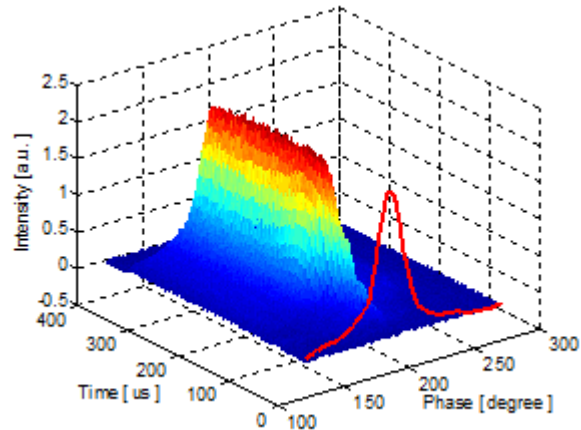

Figure 11: Bunch Shape measurement at nominal RF parameters.

Buncher Cavity Adjustment

The buncher cavity RF parameters were adjusted using the spectrometer line and the BSM. Changing the buncher phase at nominal RF amplitude, the centre of the beam distribution was observed with the wire grid in the spectrometer line. The acceleration and deceleration phases (beam at the max/min of the RF wave) and the bunching and debunching phases (beam at the zero crossing of the RF wave) were determined. The values found were cross-checked with the BSM. Increasing the RF amplitude at the correct bunching phase results in a narrower longitudinal distribution but does not change its centre position (no average acceleration). The distinction between bunching and debunching phases is also made by measuring the longitudinal distribution with the BSM, with longer bunches created in the debunching case.

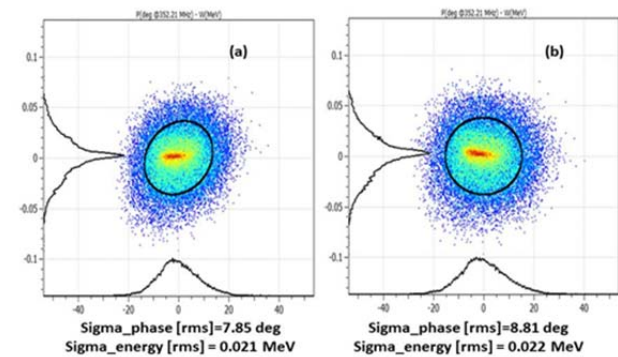

Figure 12: Longitudinal emittance expected (left) and measured (right).

The longitudinal emittance can be measured by varying the buncher RF amplitude with nominal phase settings

and measuring the longitudinal bunch distribution. This method is similar to the quadrupole scan in the transverse case. Traditionally the emittance and Twiss parameters are found by the matrix inversion technique, which only works when these transformations are linear. In our case, where space charge effects play a major role, only an initial estimation is calculated this way. These calculated Twiss parameters are used to produce a conforming particle distribution with Monte Carlo, which is followed with a tracking program (PATH), taking into account non-linear effects. Subsequently the distribution is iteratively modified until the simulation-result matches the measurement (“forward method”) [5][6].

Figure 12 compares the longitudinal phase space plot obtained through the forward method (b) with the one expected (a).

DTL RF-Adjustments

To get a rough idea about the RF settings of the DTL-1 cavity the reference amplitude was set and the beam transmission measured with a BCT in front the cavity and another one behind it. The measurement (dots in Figure 13) was taken with all bunchers in the MEBT switched off (red), and with all bunchers on and compared to the theoretical curves.

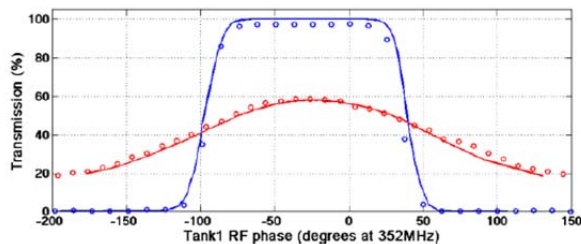

Figure 13: Transmission during phase scan.

Beam Energy Measured with Time of Flight

The BPMs used in Linac-4 are shorted striplines which allow the measurement of beam position, relative intensity and phase with respect to the 352.2 MHz accelerating frequency.

Through phase-comparison between two BPMs the time of flight between these two BPMs, and thus the average beam energy of the particles, can be determined. Using different BPM pairs permits a cross-check of the result.

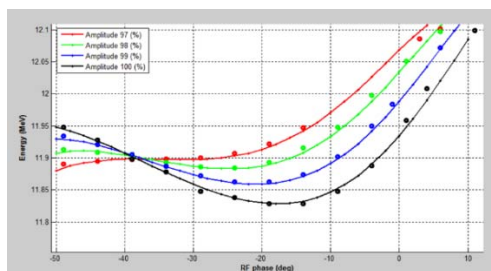

Figure 14: Beam energy versus DTL1 RF amplitude and phase (lines: simulated, points: measured).

The beam energy versus RF phase curve has a characteristic shape for a given RF amplitude. The curves were calculated with simulation programs for several RF amplitudes and compared to the corresponding time-of-flight measurements. Figure 14 shows the excellent result for DTL1. The RF parameters for the other cavities were adjusted using the same method.

50/100 MeV MEASUREMENT LINE

The slit/grid device could not be used at higher energies than 12 MeV because of the high energy-deposition in the slit. Equally, the spectrometer could not handle higher energies because of the limited field in the spectrometer magnet.

For these reasons a different measurement line was designed for 50 and 100 MeV commissioning in which the emittance is measured with 3 profile measurements and the average beam energy is measured using the time of flight between 2 BPMs used as phase probes.

The 50/100 MeV measurement line contains:

- 3 Profiler assemblies with horizontal & vertical wire grids and an L-shaped wire scanner
- 2 BPMs
- 1 BCT
- 1 laser profiler with a diamond detector
- 1 bunch shape monitor

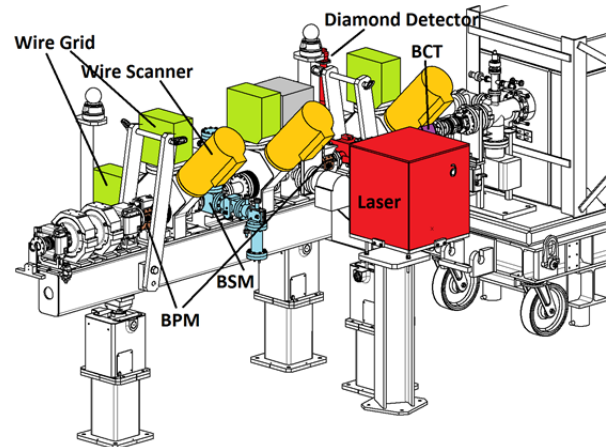

Figure 15: 50/100 MeV measurement line.

This measurement line was first installed after the third DTL tank at 50 MeV and has since been moved to after the CCDTL and the first PIMS module at 105 MeV.

Profile Measurements

When an H⁺ particle is intercepted by a grid wire it loses its electrons which can then be collected by adjacent wires thus distorting the measured beam profile. In order to estimate this effect, a profile measurement station was designed with a grid and an L-shaped wire scanner very close to each other. Comparing the profile measured with the wire scanner, which is not sensitive to crosstalk, with

the result from the wire grid shows a difference in the order of 1.5% in profile width, most of which is assumed to come from this crosstalk between neighbouring wires in the grid.

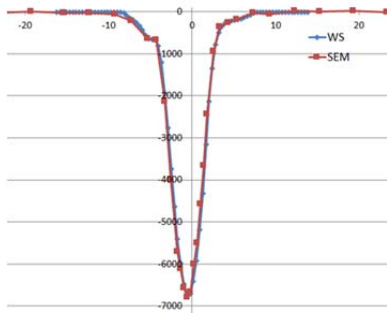

Figure 16: Grid profile (SEM) versus scanner profile (WS).

Laser Profile Measurements

Since there is no spectrometer on the 100 MeV measurement bench the H^0 atoms created through laser stripping cannot be separated from the primary H beam. It is, however, possible to extract the stripped electrons with a weak bending magnet having little effect on the primary beam. The intensity of these electrons with respect to the laser position in the beam provides the beam profile.

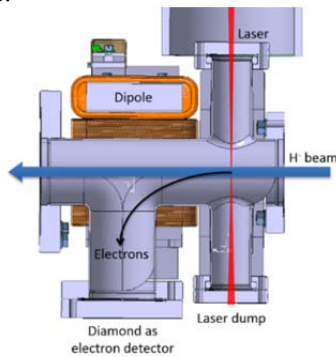

Figure 17: Laser profile.

The laser was installed between two profile measurement boxes containing wire scanners and grids. In this way the laser scanner profile could be compared to profiles from the grids extrapolated to the position of the laser.

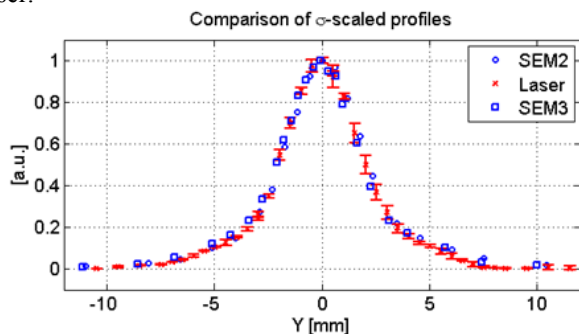

Figure 18: Comparison profiles grid and laser

Transverse Emittance

As the slit/grid method cannot be used above 12MeV a 3-profile method was used to obtain the emittance at 50 and 100MeV. Three beam profiles were measured at a phase advance of 60 degrees from each other and the emittance determined through optics calculations. As for the case of the longitudinal emittance, linear optics cannot be applied, and the “forward method” described above was therefore also used in the transverse case. The comparison between measured (red) and expected (black) Twiss parameters shows remarkable agreement (Figure 19).

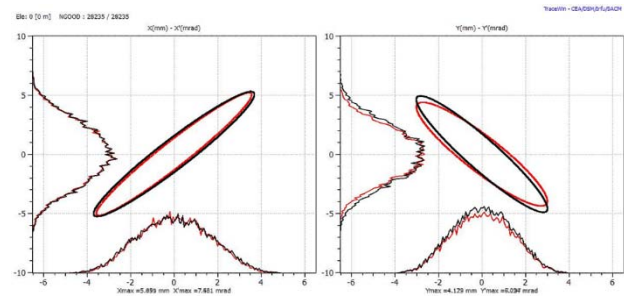

Figure 19: Twiss parameters simulated and extracted from measurements with the forward method.

CONCLUSION

CERN’s new H⁻ Linac is currently being commissioned in stages. The source, LEBT, MEBT with chopper, the DTL and CCDTL structures have all been commissioned with beam, while the PIMS cavities and transfer line to the PS Booster remain to be commissioned before the end of 2016.

Three temporary measurement lines were designed to fully characterize the beam at 45 keV, 3 and 12 MeV, and 50 and 100 MeV. Many beam parameters were measured with different instruments giving results that showed excellent agreement with theoretical predictions.

This also allowed several measurement techniques to be validated, such as transverse and longitudinal emittance measurements using the “forward method”, profile measurements using wire scanner, grids and laser stripping and energy measurement through time-of-flight between two BPMs.

ACKNOWLEDGMENTS

Many thanks go to the members of the CERN BE/BI group for help with mechanics, electronics and software. The CERN BE/ABP group supplied the simulation results and operated the machine during the measurements.

REFERENCES

- [1] V.Dimov, E. Belli, G. Bello di, J-B. Lallement, M. Yarmohammadi Satri, Beam Commissioning of Linac4 up to 12 MeV, Proc. IPAC'15, Richmond USA, May 2015, paper THPF085, pp. 3886-3889.
- [2] R. Roncarolo et al., Transverse Profile and Emittance Measurements during the CER N Linac-4 Commissioning at 3 and 12 MeV, Proceedings of Linac 2014 Geneva, Switzerland, paper TUPP035, pp. 506-509.
- [3] F. Zocca, E. Bravin, M. Duraffourg, G.J. Focker, U. Raich, F. Roncarolo, CERN Geneva Switzerland Profile and Emittance measurements at the CERN Linac-4 3 MeV Test Stand. Proceedings IBIC 2013, Oxford UK, paper WEPF09 pp. 826 – 829.
- [4] T. Hofmann, G.E. Boorman, A. Bosco, E. Bravin, S.M. Gibson, K.O.Kruchinin, U. Raich, F. Roncarolo, F. Zocca, Experimental Results of Laserwire Emittance Scanner for Linac-4 at CERN, Nucl. Inst. and Meth. in Phys. Res. Section A, <http://dx.doi.org/10.1016/j.nima.2016.02.018>.
- [5] J-B Lallement, A.M. Lombardi. P.A.Posocco CERN Linac4 Beam Commissioning Strategy Proceedings of HB2012, Beijing, China, paper TUO3B03 pp.283-285.
- [6] V. Dimov, Emittance Reconstruction Techniques in Presence of Space Charge Applied during Linac4 Beam Commissioning, paper WPEM1Y01, this conference.