

5 December 1977

EUROPEAN ORGANIZATION FOR NUCLEAR RESEARCH

CERN - LABORATORY II

SPECIFICATION FOR COAXIAL HIGH
VOLTAGE CABLE

Type RG 220/U

Ref: SPS/ABT/GV/vh/D4-115 (Revised)

(i)

C O N T E N T S

1. GENERAL SPECIFICATION
 - 1.1 Introduction
 - 1.2 Scope of the tender
 - 1.3 Delivery
 - 1.4 Layout of the accelerator and installation of the cables
 - 1.5 Samples of insulation materials
 - 1.6 Transport
 - 1.7 Technical information
 - 1.8 Guarantee

2. TECHNICAL SPECIFICATION
 - 2.1 Voltage waveforms
 - 2.2 Cable parameters
 - 2.2.1 Electrical parameters of the cables
 - 2.2.2 Mechanical parameters of the cables
 - 2.3 Cable construction
 - 2.4 Storage drums

3. TESTS ON THE CABLES
 - 3.1 Tests in the factory
 - 3.1.1 Tests to be performed on all cables
 - 3.1.2 Tests to be performed on the length of 50 meters only
 - 3.2 Tests at CERN
 - 3.3 Tests records

4. TECHNICAL QUESTIONNAIRE

1. GENERAL SPECIFICATION

1.1 Introduction

The European Organization for Nuclear Research (CERN) requires coaxial high voltage cables to be used for the transmission of high voltage pulses between the pulse generators and magnets of a fast pulsed magnet system of the 400 GeV proton accelerator (SPS).

1.2 Scope of tender

This price inquiry concerns the manufacture, testing at the contractor's premises and delivery to CERN, Division SPS, Site de Prévessin, 01631 CERN Cedex FRANCE of:

- 1370 meters of RG 220/U type coaxial high voltage cable with a characteristic impedance of 50 ohm.

In addition CERN wants to take an option for up to 13000 meters of the same type of cable.

The total length of the cable of the initial order must be subdivided into 6 elementary lengths of 220 meters and one length of 50 meters.

For the optional order, the total length of the cable must be split into 60 lengths of 200 meters and one length of 50 meters.

The cables with a length of 50 meters will be used for destructive h.t. tests. (see chapter 3.1.2)

CERN reserves the right to change the length by $\pm 10\%$ at the time the order is placed.

The manufacturer must provide all the equipment necessary for the tests to be performed at his premises (see chapters 3.1.1 and 3.1.2). CERN will provide the equipment for the tests to be performed at CERN (see chapter 3.2).

The installation of the cables does not form part of this tender.

The price must include the storage drums for the initial order. The drums for the optional delivery will be returned to the manufacturer after the installation of these cables.

1.3 Delivery

It is intended to place the contract before the 1st April 1977. Four months after the order has been placed, the cables of the initial order must be delivered to CERN.

CERN will complete the high voltage tests of the cables described in chapter 3.2 within three months after their delivery at CERN.

The optional order will be placed at the latest 18 months after the date of the initial order. The delivery of the option must be completed within 6 months from the date that the optional order is placed.

The delivery time must include the time needed for testing the cables at the contractors premises in the presence of a CERN representative, according to the procedure laid down in sect. 3.

1.4 Layout of the accelerator and installation of the cables.

Figure 1 shows the general layout of the new accelerator which is located across the French-Swiss border. The cables of the optional order will be installed at the access point : BA1, pit PP1.

The cables of the initial order will be used for the development of a prototype fast pulsed magned system and will remain wound on their drums.

The drawing 8103.8420.1 shows an isometric schematic layout of the path of the cables from the auxiliary building, down a 53 m vertical shaft to the access tunnel and the accelerator tunnel. The parts of the cables which are installed in the accelerator tunnel itself are exposed to nuclear radiation. The cables must remain in service for at least 10 years. During this time they may absorb up to 10^8 rad. (1 rad=100 erg/g). The radiation resistance of the cables is therefore of great importance and all materials used for the cable construction must be sufficiently radiation resistant. Relevant information on radiation resistance of materials can be obtained from CERN upon request.

To reduce the fire hazards in the tunnel and especially in the vertical access shafts, the cable must be flame resistant or flame retardent.

The cable installation is not part of this call for tenders, but it is included in the contract concerning the general cable installation on the site, which is already placed.

The successful tenderer must, before the signature of the contract, describe any special precautions which might be necessary during installation and is free to send an inspector to CERN to supervise the installation of the cables.

During installation each cable will be unrolled from its drum placed in the auxiliary building near the top of the pit and will be left hanging down freely during unrolling. After each cable has been unrolled it will be fixed to horizontal cable trays in the tunnel and the auxiliary building and to vertical cable ladders in the pit by means of metallic clamps. The manufacturer must indicate if he has any special requirements for the type of these clamps. The cable trays and ladders are made from galvanized iron and earthed.

1.5 Samples of insulation materials

The tenderer must send to CERN together with his offer samples of all the organic materials used in the cable. If possible, these should be sheets of about 300 x 300 x 2 mm size. Two such samples are required of the following components:

- the dielectric (polyethylene)
- the outer protection material (PVC)

CERN will make irradiation and flame tests on these samples to verify that the requirements specified in chapter 2.3 c, d and e, are met.

Offers sent to CERN without these samples will not be considered.

CERN reserves the right to request the same series of samples again before the manufacture of the optional cables.

1.6 Transport

The manufacturer is responsible for the transport of the cables to CERN. The protection against moisture, especially the sealing of the cable ends must allow storage of the cables in outdoor conditions.

1.7 Technical information

CERN demands to be continually informed of all technical details concerning the fabrication and the testing of the cables. Satisfactory facilities must be given to the CERN representatives to inspect the components during manufacture and testing at the premises of the contractor. No departure from the technical specification is allowed without the written approval of CERN.

For the tests to be performed in the factory (chapter 3.1.1 and 3.2.1) CERN must be informed at least one week in advance of the date at which these tests will commence.

1.8 Guarantee

All cables must be guaranteed for at least 10^7 discharge pulses or two years after provisional acceptance by CERN.

The manufacturer must guarantee that until the end of the guarantee period each cable still meets the original specification.

2.- TECHNICAL SPECIFICATION

2.1 Voltage waveforms

The general electrical circuit in which the cables will be used is shown in fig 2. Capacitors are interconnected with inductances to form a LC-ladder network (PFN) with a characteristic impedance of 6.25 ohm. High power switches discharge the PFN through a matched transmission line into its magnet which is followed by a terminating resistor matched to the characteristic impedance of the PFN. An RLC section between the PFN and the switches (front cell) provides a short pulse rise time. The current pulse has a rectangular shape. (fig.3) Its duration can be adjusted by suitable timing of the triggering of the switches between 1 and 12 μ sec. The transmission line which connects the PFN to its magnet is made of eight coaxial cables in parallel.

The potential of the inner conductor is positive with respect to the outer conductor, which is earthed at its extremities.

The main characteristics of the pulsed magnet system, which will make use of the cables described in this specification are given in Table 1.

TABLE I

Pulse voltage	35 kV
Characteristic impedance of the system	6.25 Ω
Maximum current amplitude	5.6 kA
Pulse duration	1.0 to 12.0 μ s
Characteristic impedance of the cable	50 Ω
Number of cables in parallel for each magnet system	8 + 2 spares
Pulse repetition time	0.3 sec

2.2 Cable parameters

The cable must be manufactured in accordance with the US Military Specification MIL-C.17D (RG types) and US Military Specification sheet MIL-C.17/81, except for the following parameters:

2.2.1 Electrical parameters of the cables

Real component of the characteristic impedance measured 1 MHz	50 Ω \pm 1%
Maximum deviation from the measured average value of the real component of the characteristic impedance at any place along the entire cable length at 1MHz	\pm 1%
Maximum change in the real component of the characteristic impedance between 100 kHz and 30 MHz	2%
Maximum variation of the velocity of propagation between 100 kHz and 30 MHz	\pm 2%

Maximum attenuation in dB per 100 m at
a frequency of

0.1	MHz	0.05	dB
1.0	"	0.17	"
10.0	"	0.57	"
30.0	"	1.0	"

Maximum ionization level at a voltage of

20 kVrms/50Hz 100 pC

Maximum value of $\tan\delta$ at a voltage of

20 kVrms/50Hz 10^{-4}

Temperature range during temporary storage -25°C to $+40^{\circ}\text{C}$

Temperature range during operation and
installation $+15^{\circ}\text{C}$ to $+35^{\circ}\text{C}$

Maximum relative humidity 100%

2.2.2 Mechanical parameters of the cables

Outer diameter of inner conductor	6.67 ± 0.02	mm
Inner diameter of outer conductor	23.1 ± 0.3	mm
Outer diameter of jacket	28.4 ± 0.4	mm
Maximum excentricity between inner and outer conductor at any place along entire cable length	0.4	mm
Minimum bending radius of installed cable	\leq 0.6	m
Minimum bending radius during installation	\leq 0.8	m

2.3 Cable construction

a) The design of the cable must take into account the mechanical stresses due to the vertical position of the cable in the 53 m deep access pit. The tenderer must ensure that the resulting mechanical and electrical deviations are within the tolerances of this specification.

- b) The conductors must be drawn from copper, the resistivity of which is in accordance with IEC Publication 28.
- c) The dielectric must be high purity polyethylene. Its quality and its manner of extrusion is of critical importance for the high voltage behaviour. To ensure good mechanical properties and to avoid cracking of the insulation under mechanical and electrical stress, the melt index of the polyethylene must be 0.3 or lower.
- d) The material of the outer protecting jacket must be polyvinylchlorid (PVC). The quality used must be such that the polyethylene insulation is not damaged by migration of the PVC-plasticizer. Alternatively mylar tape may be applied between the outer conductor and PVC sheath. The oxygen index of the PVC must not be lower than 28, measured following ASTM-D-2863-70.
- e) The cable must be flame retardent according to the specifications DIN 53438 Klasse K1 and F1 as well as IEC 332. Information about these specifications can be obtained from CERN upon request.
- f) All materials used in the cable construction must be radiation resistant. Relevant information on radiation resistance of organic materials can be obtained from CERN upon request. CERN requires that the tensile strength of all materials used in the cable is still at least 50 % of the initial value after irradiation with a total dose of 10^8 rad.

2.4 Storage drums

The manufacturer must deliver three lengths of cable on one drum. For the initial delivery at least 5 m of each cable must be accessible at each extremity. The drums for the initial order must be delivered as property of CERN. The drums of the optional order will be returned after the installation of the cables. The cable installation will take place at the latest 6 months after the delivery of the cables.

Each drum must bear the following indications:

- number of the contract
- characteristic impedance
- number of cables and their lengths
- net and gross weight
- drum number
- rolling direction.

3. TESTS ON THE CABLES

3.1 Tests in the factory

3.1.1 Tests to be performed on all cables

The following tests must be performed in the presence of a CERN representative and in the sequence indicated below on each of the elementary cable lengths of 220 metres and 50 metres.

a) Ionization inception level of the polyethylene cable core.

After the polyethylene extrusion the ionization inception level of the unbraided cable core must be continuously measured along the entire cable length by means of a partial discharge detector. The voltage applied must be 35 kVrms/50Hz. The ionization level measured must not exceed 5 pC. The sensitivity of the detector must be at least 1 pC. The measurements have to be recorded graphically by means of a pen recorder.

b) Geometrical control

During the production process the excentricity between the inner conductor and the polyethylene outer surface must be continuously measured along the entire cable length and recorded by a pen recorder. On each finished cable the diameter of the inner and outer conductors have to be measured over 10 cm at both extremities.

The results must be within the tolerance given in chapter 2.2.2

c) Capacitance

The capacitance of each cable must be measured to at least three significant figures at a frequency of 1000 Hz and reported in picofarad per meter.

d) Characteristic impedance, attenuation and velocity of propagation

The real and imaginary component of the characteristic impedance, the attenuation and the velocity of propagation must be measured for each cable at the following frequencies:

0.1	MHz
0.5	"
1.0	"
5.0	"
10.0	"
30.0	"

The measurements must be plotted graphically. The results have to stay within the tolerances given in chapter 2.2.1

e) Uniformity of impedance

The variation of the impedance along the entire length of the cable must be shown to lie within the figures specified in chapter 2.2.1

f) High voltage test

A voltage of 35 kVrms/50 Hz must be applied during 30 min. without any break down.

3.1.2 Tests to be performed on the lengths of 50 meters only.

a) Ionization inception level of finished cables

On each cable the ionization inception level must be measured as a function of the voltage by means of a partial discharge detector. The sensitivity of the detector has to be at least 1 pC. The maximum voltage is 20 kVrms. The frequency is 50 Hz. The ionization at 20 kVrms must not exceed 100pC. The results have to be represented graphically.

b) Loss factor $\tan \delta$

The loss factor $\tan \delta$ must be measured as a function of the applied voltage. The frequency is 50 Hz, the maximum voltage 20 kVrms. The results must be given graphically and must not exceed the figure given in chapter 2.2.1

c) Destructive sample test

The cables of a length of 50 m each will be subjected to a destructive high voltage test. The frequency is 50 Hz. The test starts with a voltage of 35 kVrms, which must be applied during 24 hours. If the cable withstands, the test will be considered as successful. Thereafter the voltage will be increased in steps of 5 kVrms per hour until the breakdown occurs.

The manufacturer must supply all the equipment, which is needed for the execution of the tests mentioned in chapters 3.1.1 and 3.1.2. Tenderers who are unable to comply with tests 3.1.1 a) and f) and 3.1.2, a), b), and c) because they do not possess the test facilities should state in their offer the alternative tests which they propose in order to verify the high voltage performance of the cables. However, CERN will not consider offers from firms which are unable to verify the performances required in this technical specification.

3.2 Tests at CERN

Each cable will be subjected to a pulse voltage test of the following characteristics :

- charging voltage	:	35 kV
- discharge mode	:	oscillatory with 85 % voltage reversal
- pulse repetition rate	:	3 pps
- number of discharges	:	500.000

The manufacturer is free to send a representative to assist with this test at CERN.

If the cables fail to meet any or the tests, the manufacturer must improve its design and make at his own expense additional cables until satisfactory cables have been produced.

If this test is not performed within 3 months after delivery to CERN, the cables will be considered as provisionally accepted.

3.3 Test records

The manufacturer must send to CERN test reports in triplicate for the tests described in chapters 3.1.1 and 3.1.2.

The results of the following tests must be supplied in form of pen recorded charts:

Ionization inception voltage of extruded polyethylene cable core.
Geometrical control of excentricity.

The results of the tests:

Ionization level of finished cable
Characteristic impedance, attenuation and velocity of propagation.
Loss factor $\tan \delta$

must be represented in the form of graphs.

All other test results must be written down on a record sheet.
All the results must be sent to CERN with the corresponding cable.

4. TECHNICAL QUESTIONNAIRE

The tenderer must give in his offer a detailed description of the proposed cable. In particular, he is requested to supply a drawing of the cables with dimensions and to answer the following questions:

1. Which materials will be used for the proposed cables?
What is for the inner and outer insulation materials
 - the chemical composition,
 - the radiation resistance ?
2. What is the dielectric constant of the polyethylene after extrusion?
3. What is the melt index of the polyethylene ?
4. What is the oxygen index of the PVC sheath ?
5. What is the minimum permissible bending radius of the proposed cable ?
 - during installation,
 - for permanent installation on the cable tray?
6. What is the unit weight of the finished cable ?
7. What are the proposed diameter and width of the drums ?
8. How many elementary lengths of 220 m are mounted on one drum?
9. What will be the maximum voltage and sensitivity of the ionization inception measuring system ?

Offers without answers to this questionnaire and/or without the samples required in section 1.5 will not be considered.

Fig. 1

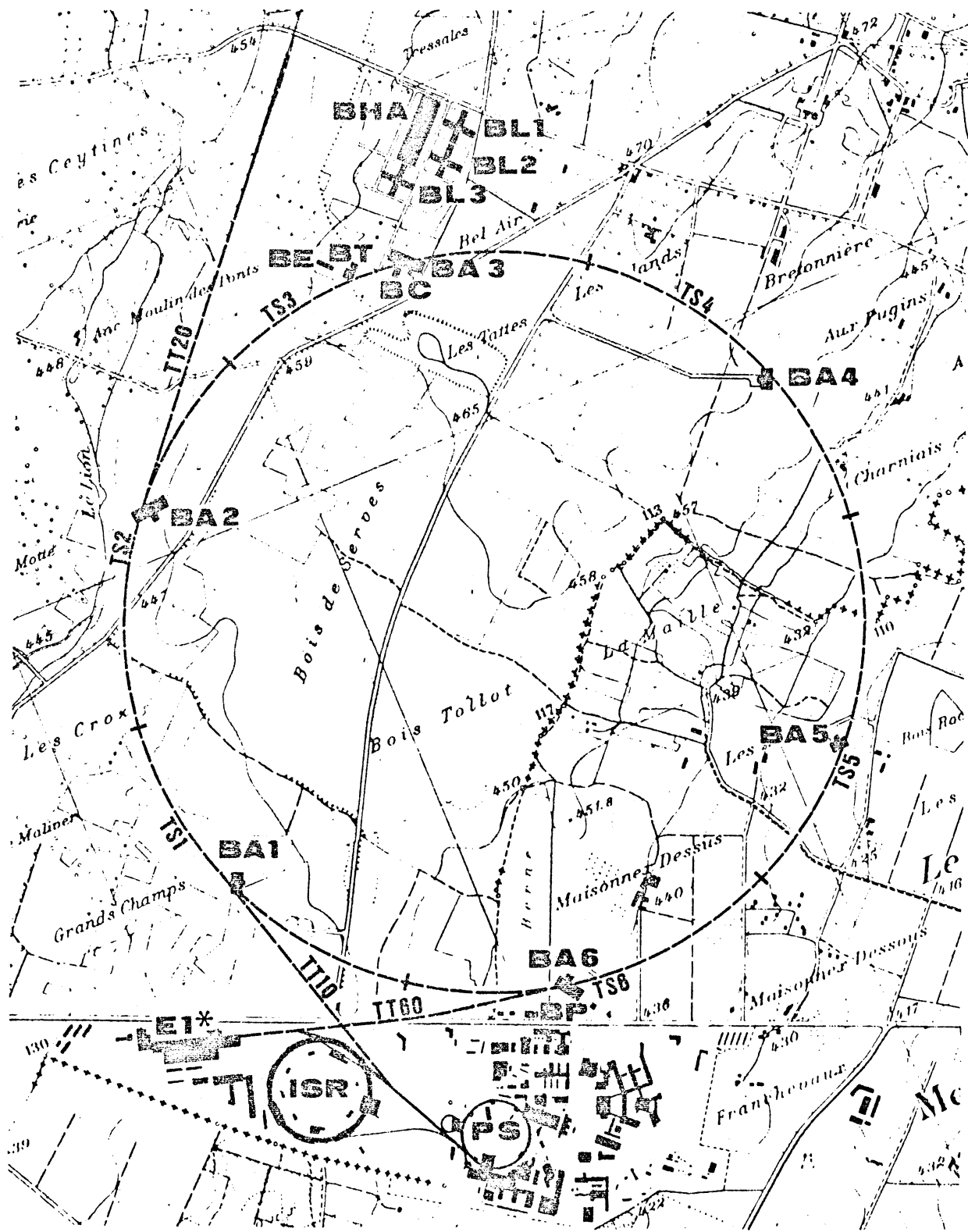

General accelerator layout

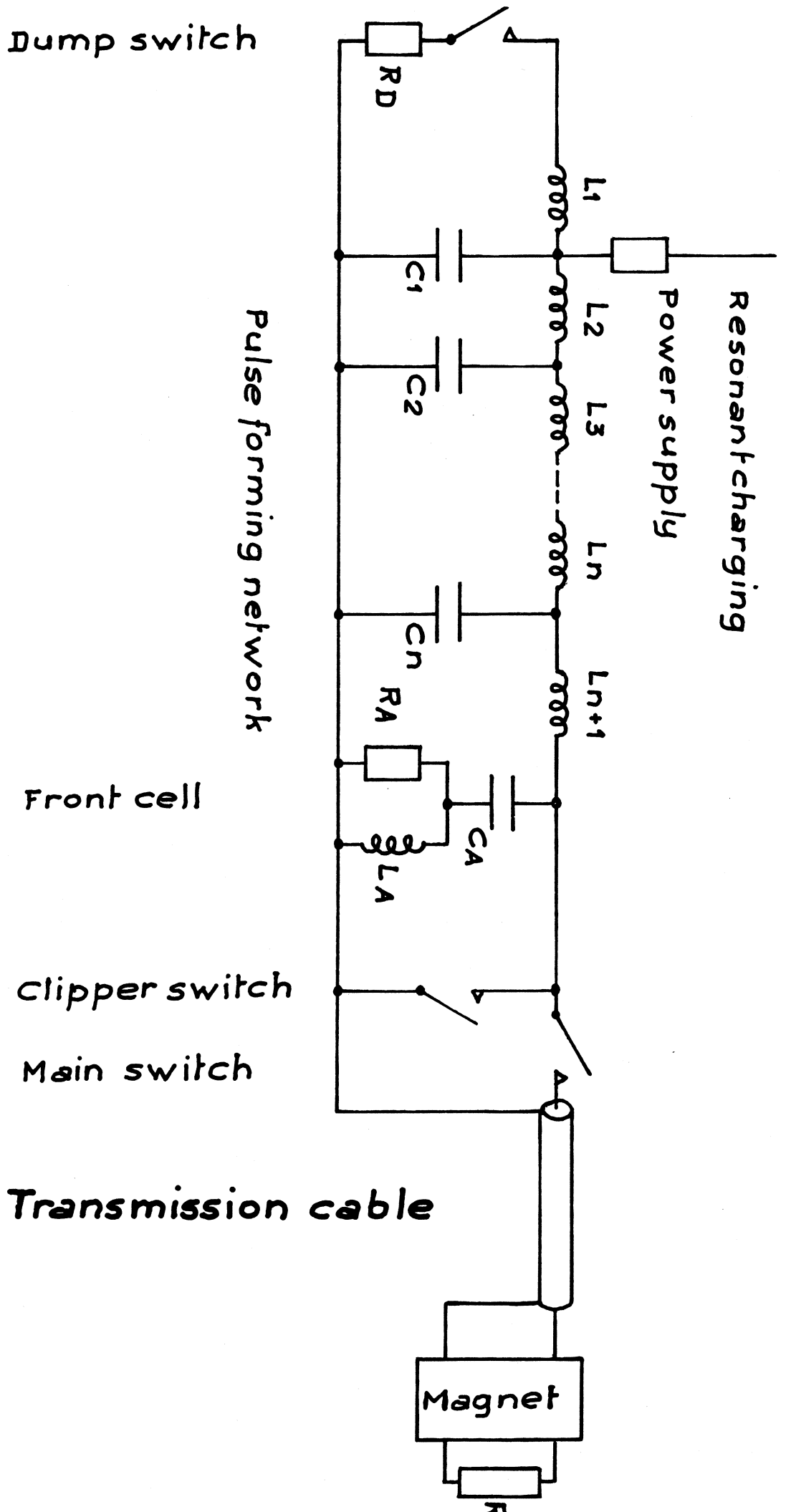

Fig.2- Electrical circuit of the PFN