

## STATUS OF THE SRF SYSTEMS AT HIE-ISOLDE

W. Venturini Delsolaro, L. Arnaudon, K. Artoos, C. Bertone, J. A. Bousquet, N. Delruelle, M. Elias, J. A. Ferreira Somoza, F. Formenti, J. C. Gayde, J. L. Grenard, Y. Kadi, G. Kautzmann, Y. Leclercq, M. Mician, A. Miyazaki, E. Montesinos, V. Parma, G. J. Rosaz, K. M. Schirm, E. Siesling, A. Sublet, M. Therasse, L. Valdarno, D. Valuch, G. Vandoni, L. R. Williams, P. Zhang

CERN, Geneva, Switzerland

### Abstract

The HIE-ISOLDE project has been approved by CERN in 2009 and gained momentum after 2011. The final energy goal of the upgrade is to boost the radioactive beams of REX-ISOLDE from the present 3 MeV/u up to 10 MeV/u for A/q up to 4.5. This is to be achieved by means of a new superconducting linac, operating at 101.28 MHz and 4.5 K with independently phased quarter wave resonators (QWR). The QWRs are based on the Nb sputtering on copper technology, pioneered at CERN and developed at INFN-LNL for this cavity shape. Transverse focusing is provided by Nb-Ti superconducting solenoids. The cryomodules hosting the active elements are of the common vacuum type. In this contribution we will report on the recent advancements of the HIE-ISOLDE linac technical systems involving SRF technology. The paper is focused on the cavity production, on the experience with the assembly of the first cryomodule (CM1), and on the results of the first hardware commissioning campaign.

### INTRODUCTION

At the end of 2014 the HIE-ISOLDE project [1] was well launched into its construction phase, with all the main components being procured or assembled. The phasing of the project had been revised at the beginning of the year; yet the schedule was tight with the target of delivering the first beams for physics in October 2015. While the technical infrastructure work was progressing well, the cryogenics facilities had still to be installed and commissioned. The cavity series production had just started and was delayed by issues with the quality of the copper substrates produced in industry. The first assembly of a cryomodule in the new clean room was just then starting and the actual assembly time was only known with a large uncertainty. The status of the project at this stage is documented in [2]. At that time it was still foreseen to proceed with a full characterization of the assembled cryomodule in a dedicated cold test facility, before shipping it to the HIE-ISOLDE linac. However, at the end of the year it became clear that this was incompatible with a physics run still in 2015. The decision was then taken to test the cryomodule directly in the linac. The plan for 2015 was to complete the cavity production and the assembly of the first cryomodule, in parallel with the installation of the cryogenics facilities at HIE-ISOLDE, and then to commission the whole

complex altogether. The High Energy Beam Transfer lines would also be installed and commissioned in the same lapse of time. All going well, a physics run could be envisaged for the end of 2015.

This paper is centred on the aspects of the HIE-ISOLDE project which are related to SRF technologies. A more general status report on the project is given in [3].

### SCRF CAVITY PRODUCTION

After a development phase ended in 2013 [4], the series production of HIE-ISOLDE SRF cavities started in 2014. Copper cavity substrates are manufactured in industry, whereas all the subsequent work needed to produce the Nb/Cu QWR and qualify them for installation is carried out at CERN. The workflow, shown in Fig. 1, comprises 12 steps, traced within the CERN standard manufacturing and travelling folder system (MTF). The whole process takes about 7 weeks.

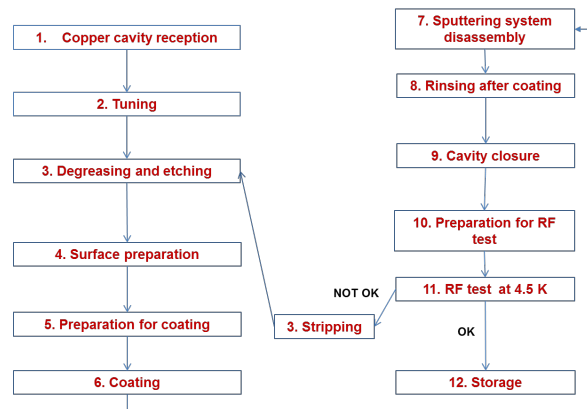

Figure 1: Nb/Cu QWR production workflow.

### Acceptance Tests of the Copper Substrates

Upon arrival at CERN, the copper cavities are visually inspected with a portable microscope, in particular around the electron beam weld joining the inner and outer conductors of the QWR, located in the high magnetic field region. This first visual inspection is done before any chemical treatment; therefore it is only useful to spot gross defects. The helium volume inside the cavity inner conductor is also leak tested as a part of the cavity acceptance step. Dimensional checks in the metrology lab are carried out on a sample of cavities or in case of doubts.

The resonance frequency of the cavity as built is checked under controlled temperature and humidity conditions.

### Pre Tuning

The tuning strategy HIE-ISOLDE cavities is described in [5]. The needed amount of chemical etching is judged at the optical inspection stage. Etching time is one of the contributing factors which determine the required trimming length of the cavity outer conductor, according to a known correlation. The resonance frequency to be achieved at warm must also account for all the other frequency shifts introduced later in the process, including the cool down to 4.5 K and operation in vacuum. The available tuning range of the mechanical tuner [6] is less than 40 kHz. Two types of tuning plate are predisposed for the cases when the cavity needs to be stripped and recoated, and therefore might fall out of the tuning range due to multiple chemical polish steps.

### Surface Preparation

The preparation of the copper surface prior to Nb coating is described in [7]. For new cavities the chemical polishing is applied in two steps: a first treatment serves to remove superficial defects and to check for eventual hidden problems notably on welds. The second step is carried out immediately before mounting the cavity in the sputtering chamber. Low pressure (5.5 bar) water rinsing in an ISO5 clean room is used to remove all traces of chemicals.

### Niobium Sputtering

After drying with ethanol in clean room for one night, the cavity is moved into another ISO5 area to install the sputtering gear. Nb coating is carried out according to an established protocol described in [7].

Following the completion of 5 Nb/Cu cavities for the first cryomodule, the series production was paused for a few months, primarily due to the slow delivery rate of acceptable copper substrates. In this time interval, some experiments were made aiming to improve the coating recipe. The performance of the first series cavity (Fig. 2) had been inferior to the best results repeatedly achieved in the development phase. One of the possible reasons was that the CERN produced substrates used during development had seen several coatings, implying cycling at high temperatures (650 °C). This seemed to be confirmed when the least performing cavity of the series batch was stripped and coated again, reaching performances comparable to the best cavities. Another direction of development started from the consideration that the Nb layer had been found to be porous on the cavity top, where the deposition rate is smaller, and where the RF currents are highest. Two experiments were made in which the deposition rate at the cavity top and the bias voltage were increased at the same time. The resulting layers were as expected free of porosities and appeared smooth under microscopic observation [8]. Nonetheless the cavity performance was disappointing, displaying

anomalously high Q-slope. Further analyses of the samples highlighted a distributed lack of adhesion at the microscopic scale, which might be linked to the observed increase in the low field Q-slope.

### RF Tests at Cold

After careful disassembly of the sputtering cathode, the coated cavity is rinsed with pure water in the ISO5 area, and then closed with the Nb coated copper bottom plate, before shipping it to the vertical tests facility. Preparations for the cold test (mounting on vertical cryostat insert of the RF coupler and tuning systems, instrumentation etc.) are carried out in another ISO5 clean room. The cryostat is pumped down slowly to limit dust contamination.

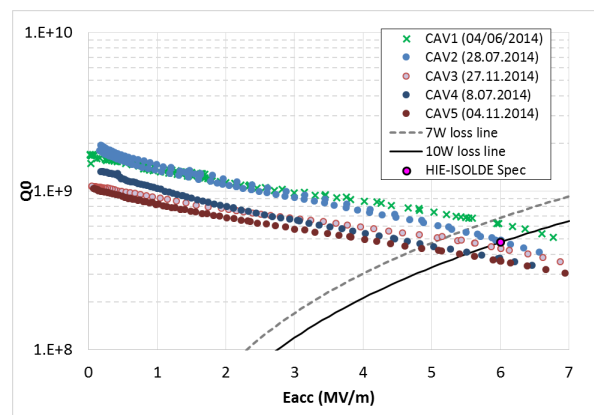

Figure 2: vertical test results of CM1 cavities.

Cavities are measured after the first cool down to 4.5 K and a second time after a thermal cycle above  $T_c$  to minimize the temperature gradient along the cavity when crossing  $T_c$ . This procedure was found to yield optimal residual resistances in the vertical tests [9]

### Issues with Copper Substrates Quality

The main problem encountered during series cavity production was the presence of defects on the surface of the copper cavity substrates, of the kind shown in Fig. 3.



Figure 3: defect at the weld HAZ of the third cavity.

This issue is recurrent and it is still under investigation. In one case the defects were repaired with a second weld

at CERN, after which the cavity was coated with good results. Recently one cavity was singled out for destructive analysis in order to pinpoint the cause of the problem.

## FIRST CRYOMODULE ASSEMBLY

### *Infrastructure and Tools*

The mechanical assembly of HIE-ISOLDE cryomodules is realised in a dedicated clean room, shown in Fig. 4. Its main characteristic is the horizontal direction of the laminar flow, which allows a large opening in front of the room and the use of a specially designed assembly tower, to handle the heavy (up to 3.5 tons) pre-assembled elements. The transition between the ISO5 area, used for the assembly proper, and the ISO7 part, used for preparation of tools and personnel, is gradual and not materialised. Another adjacent ISO5 area is dedicated to the preparation of parts. Besides the assembly tower, the special tooling kit comprises precisely aligned rails running from outside the clean room to the ISO5 area, which allow accurate positioning of sub-elements below the assembly frame; and two trolleys, to handle generic elements, cavities, and solenoid.



Figure 4: The HIE ISOLDE Clean room.

### *Assembly Procedures*

The cryomodule assembly process is subdivided into 14 sub-assembly phases, each detailed in a written procedure. Procedures are constantly reviewed and corrected to incorporate experience gained on the field.

Late in the assembly sequence comes the installation of the RF cavities and couplers, done as late as possible in order to minimize their dwell time in the clean room and thereby the risk of contamination. Also, this makes the cavities and RF lines easily accessible in case of need.

The superconducting cavities surfaces are protected against contamination by shutters which remain closed until just before the final sealing of the cryomodule.

### *Quality Assurance*

The assembly process was interleaved with holding points predisposed to check the quality of the sub-assemblies all along the process. Survey measurements, leak tests, residual gas analyses, and electrical tests of the instrumentation allow non conformities to be spotted early and to correct errors before proceeding in the sequence.

Before installing the RF cavities, the whole cryomodule was closed and leak tested with all the helium circuits set at their operational pressures.

### *Assembly Experience*

There are more than 10000 parts to be assembled to form a cryomodule. A complete blank assembly of all these parts as received, before beginning the actual clean room work, had to be ruled out due to the tight schedule. Blank assembly was maintained only for the more critical steps like the installation of the superconducting cavities.

Initially the most frequent issues were seizing of stainless steel fasteners (due to the difficulty of visually recognizing pieces treated with the Kolsterizing® technique), and non-conforming parts that had to be reworked, slowing down the process.

Hydrocarbon pollution was detected by RGA analysis of the top plate assembly vacuum. The pollution was traced to the welded bellows used for the tuners feedthroughs, and could be cured by repeated cleaning and vacuum baking.

More exhaustive accounts of the experience with the first cryomodule assembly can be found in [10, 11].

The assembly time of the first cryomodule amounted to 32 working weeks from September 2014 to April 2105.



Figure 5: One of the final stages of CM1 assembly.

## CRYOGENICS FACILITIES

The cooling capacity needed to maintain the HIE-ISOLDE superconducting linac systems at the foreseen operational temperatures is provided by an existing helium refrigerator, manufactured in 1986 and previously serving one of the LEP experiments. After refurbishing in industry, the cold box was installed in one of the new buildings close to the HIE-ISOLDE experimental hall. A new cryogenic distribution line, consisting of a 30-meter



long transfer line, a 2000-liter storage Dewar, and six interconnecting valve boxes, completes the cryogenics complex (Fig. 6). The cold box was rated for a refrigeration power of 650 W at 4.5 K. Due to the common vacuum design of the cryomodule, the availability of the cooling capacity for the thermal shield has a direct impact on the RF cavity vacuum. Any stop of the cold box is immediately reflected on the temperature of the cryomodule thermal shield. The consequent outgassing phenomena entail the risk of repopulating multipacting levels and of enhancing the activity of field emitters.

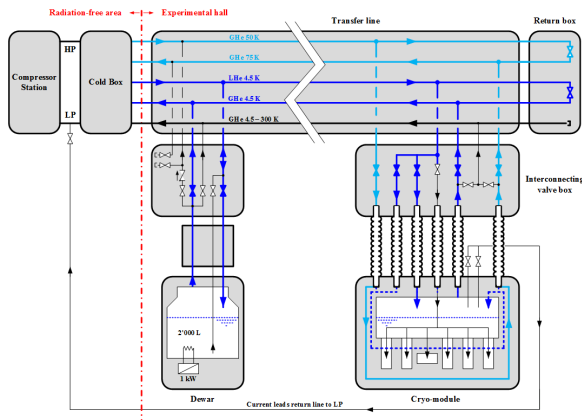

Figure 6: The HIE ISOLDE cryogenics complex.

The performance of the cryogenics plant is also affecting the RF systems through the fluctuations of the helium bath pressure, which represents the main contributor to the slow cavity detuning to be compensated by the tuning system.

The availability of the cryogenics plant has been close to 100% during the first two months of operation [12]. More recently, several outages occurred due to diverse causes. On one occasion, a malfunctioning in the cryogenics plant caused the rupture of a burst disk protecting the 4.5 K systems of the cryomodule. The event was thoroughly analysed and corrections were implemented [13].

## COMMISSIONING OF CM1

The hardware commissioning phase of the cryomodule was aimed at qualifying the performance of all the subsystems with respect to the design, and to consequently define the envelope of parameters within which the active elements could be used during beam commissioning and operation. The planned test campaign was completed in 11 weeks, but the cryomodule has not yet been released to the operations team due to a limitation found on the RF power feeds, requiring further work.

### Cryomodule Pump Down, Vacuum Performance

The first pump down of the finished cryomodule was realized at the end of the assembly in front of the clean room, for the final leak detection and pressure tests. The common vacuum design imposes constraints on the pump

down and venting procedures: in order to avoid stirring of dust that might contaminate the RF cavities, the gas velocity fields were verified in all transient phases down to the molecular regime. The target was to maintain the flow velocity around the cavities below 0.3 m/s. The cryomodule was transported under static vacuum with sector valves pinched off. Starting from  $10^{-6}$  mbar at room temperature, the cryomodule pressure outside the thermal shield reached  $5 \cdot 10^{-11}$  mbar after cool down.

### Transport and Installation

The first cryomodule was carefully transported to the ISOLDE hall on May 1<sup>st</sup> 2015 by means of a specifically designed tool to minimise accelerations. Considering the internal degrees of freedom, the choice was to let the assembly free to oscillate under gravity rather than blocking it. Gravity was exploited to maintain the cryomodule vertical at all times. The achieved maximum acceleration was less than 0.1 g. The transport tool is shown in Fig. 7. Interconnection work in the tunnel followed to fit cryogenics, vacuum, and RF utilities.



Figure 7: Transport of the first cryo module to the hall.

### Cryomodule Cool Down

The first cool-down of CM1 was successfully carried out between June 4<sup>th</sup> and 19<sup>th</sup> 2015, as shown in Fig. 8. Precise requirements on pre-defined temperature differences in the most sensitive structures (thermal shield and supporting frame) were imposed to prevent excessive deformations of the cryomodule elements due to transient differential shrinkage during cool down.

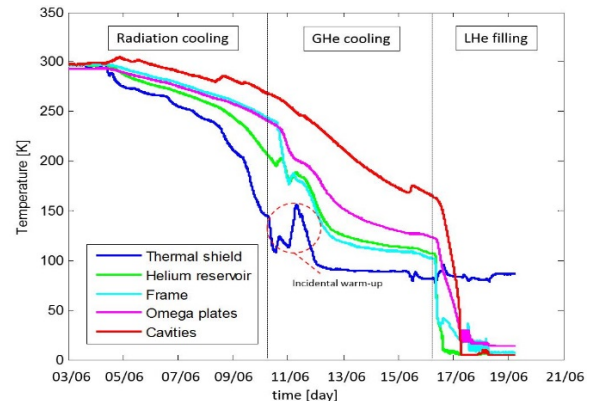

Figure 8: CM1 first cool down to 4.5 K.

Measurements of the static heat load at 4.5 K were carried out by monitoring the boil off rate of the helium bath and the temperature evolution of the supporting structure. The static heat load at 4.5 K was found to be of the order of 10 W, well in line with design values [14].

*Survey and Alignment of Active Elements*

The positions of the active elements (cavities and solenoid) relative to cryomodule fiducials were monitored during cool down by means of the Monitoring and Alignment Tracking for Hie-IsoLDE (MATHILDE) system described in [15], [16], and [17]. The observed displacements during cool down are shown in Fig. 9.

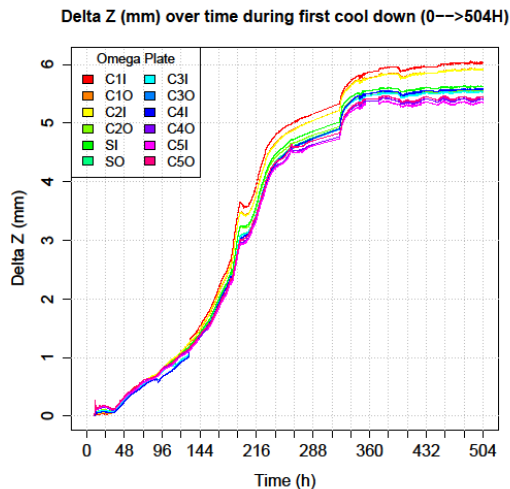

Figure 9: vertical displacements of cavities and solenoid during cool down of CM1.

Realignment on the nominal beam axis was done in two steps. The first step, before cool down, was done using the supporting jacks. Non conformities of the cryomodule beam ports and interface with the inter-tank bellows had to be considered to find the best compromise.

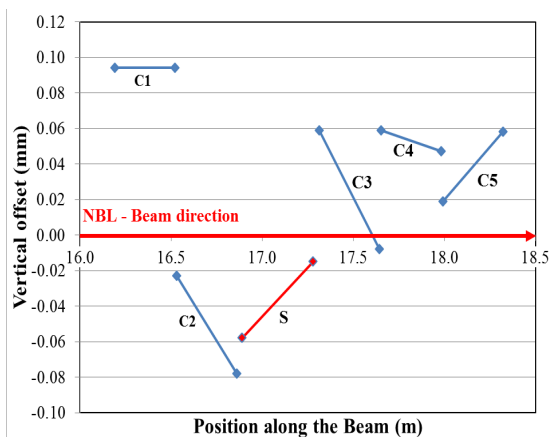

Figure 10: positions of CM1 cavities and solenoid after cold alignment (vertical plane).

Only realignment in the vertical plane was considered necessary, a systematic offset of 0.4 mm in the horizontal plane was left uncorrected for the time being. The final

position of the active elements in the beam reference system are shown in Fig. 10.

*RF Conditioning*

The multipacting levels of the HIE-ISOLDE QWR are known from simulation and experience [18]. The low field multipacting is processed during cool down, before the cavity becomes superconducting. The conditioning is made easier by the higher intrinsic bandwidth. The typical conditioning time is 4/5 hours per cavity. The high field multipacting band around 1.5 MV/m can only be reached at cold. In this case, conditioning with the cavity locked by the self-excited loop function of the low level RF system proved very effective, as the resonance frequency shifts induced by multipacting could be continuously tracked, and the power transfer to cavity was optimised.

*RF Measurements*

The Q vs E curves of all 5 CM1 cavities as measured in the cryomodule are shown in Fig. 11.

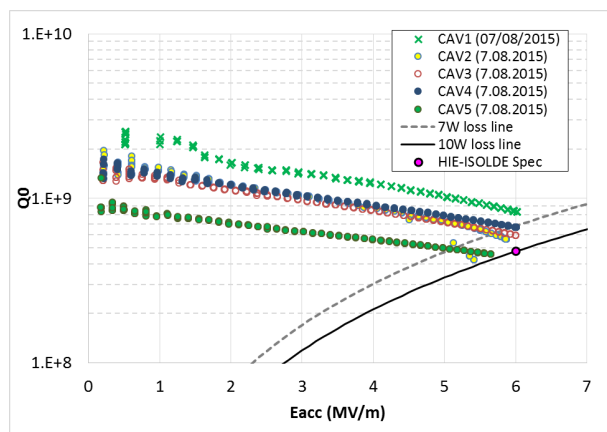

Figure 11: CM1 cavity performance at 4.5 K.

The improvement in the measured Q with respect to the vertical tests is evident comparing Fig. 2 and Fig. 11 and this fact is not yet understood. Systematic errors in one or both measurement sets were intensely searched for and not found, but remain a possible explanation. On the other hand it can't be excluded that the surface resistance might have truly decreased: a small Q switch in cavity 1 is found in both measurements around the same field, and the multipacting levels were also found at the expected fields. Actually, only Q values have changed. The cooling conditions and the way the cavities are supported are different in the vertical tests and in the cryomodule, but the reduction of surface resistance is not systematic: cavity 5 and cavity 2 gave similar results in the two measurements. All cavities were freshly rinsed just before assembly in the cryomodule, after several months of storage. The first measurements in the cryomodule were done under excellent vacuum conditions (in the 10<sup>-11</sup> mbar range), whereas the vacuum pressure in the vertical cryostat is much higher, albeit still in the low 10<sup>-8</sup> mbar range. In the cryomodule, only one cavity had mild field emission above 5 MV/m at the first powering. Field emission increased, and multipacting was repopulated,

following vacuum degradations due to cryogenics outages and the opening of vacuum sector valves on the adjacent warm beam lines, where the vacuum pressures are higher.

The stray magnetic field of the superconducting solenoid at maximum current had been designed to be one order of magnitude less than literature values of  $H_{c1}$ , but the real  $H_{c1}$  of our sputtered Nb was not precisely known. Hence, an important milestone was reached when all superconducting elements (cavities and solenoid) were successfully powered at nominal field at the same time. This provided experimental evidence that the stray field from the superconducting solenoid is not perturbing the cavities.

### LLRF Tests

The state of the art, fully digital HIE-ISOLDE low level RF system was deployed for the first time to control the first cryomodule. The system can run the cavities in a self-excited loop mode, for measurement and conditioning, or in a generator driven mode for beam operation. Designed for the latter function to lock the cavity field in phase and amplitude within tight tolerances (0.1% and 0.2 deg. respectively), it also controls the tuning system, coping with slow frequency drifts to minimize the rms power. The system also compensates for very large Lorentz force detuning (up to 25 bandwidths) when changing the operating point from low field to the nominal 6 MV/m. The dynamics of the feedback loops have been carefully optimized to smoothly cope with the set point transients. The specifications were greatly exceeded, as shown in Fig. 12.

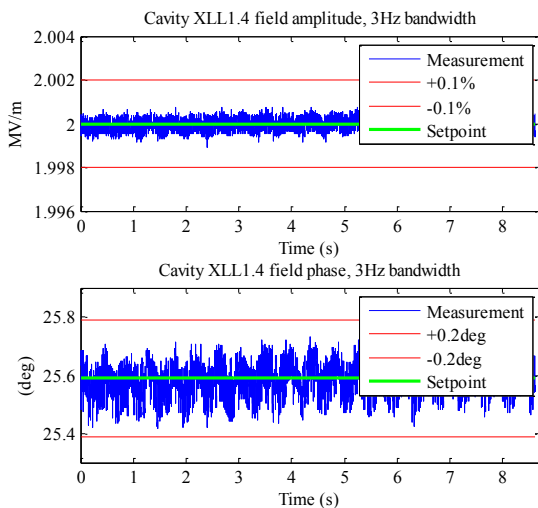

Figure 12: example of the performance of the low level RF loops with 3 Hz bandwidth at 2 MV/m.

After cool down, all cavities were found to resonate very close to the target linac frequency of 101.28 MHz, with the tuner at its mid-range position, leaving ample margin for dynamic corrections. Thanks also to the solid copper cavity bodies, the measured microphonics were well below 1 Hz, which opens the way to operation with reduced RF power.

### INSTABILITY OF RF INPUT LINES

During the first tests of the low level RF system at enlarged bandwidths, it was noticed that the RF signals displayed drifts in time which could be interpreted as effects of thermal expansion at the coupler antennas. A crash program was started at CERN to understand the issue. Measurements in a vertical cryostat evidenced that the RF couplers could indeed overheat when the systems were running for a several hours at about 100 W. It was demonstrated that the installed couplers may fail if running continuously at the initially assumed bandwidth (10 Hz) requiring 160 W of CW RF power. The origin of the problem is thought to be an insufficient thermalization of the inner conductor in the RF power line.

While correcting actions are being taken for the next cryomodules, for the units already installed the efforts are directed towards reducing as much as possible the operational bandwidth by means of refinements of the LLRF loops. Tests have shown that the required field quality can still be achieved at bandwidths reduced down to 2-3 Hz (requiring CW power below 40 W), at an expense of a higher dynamic power requested by the loops.

It is also being considered to operate with a reduced duty cycle in order to let the RF feed systems cool down in between runs. Under these conditions, an experimental physics run at the end of 2015 may still be delivered.

### CONCLUSIONS AND OUTLOOK

The progress of the HIE-ISOLDE project in the last year, and of the SRF systems in particular, has been remarkable.

All technical infrastructures were deployed, the cryogenics plant was installed and it is now operational.

The production of SRF cavities was continued in spite of all difficulties and the first five series cavities were delivered on time for installation in a cryomodule.

The first cryomodule was successfully assembled in clean conditions, transported and installed in the machine.

The qualification tests were globally positive: the vacuum performance, static heat loads, alignment accuracy, the performance of the superconducting elements, and that of the low level RF systems were satisfactory. A problem with the stability of the RF couplers was identified and it is still being addressed at the time of writing.

Beam commissioning is now about to start, aiming for a short experimental run with delivery of beam to the experiments at the end of this year.

### ACKNOWLEDGMENT

We would like to express our warmest thanks to all the project staff at CERN and in industry for their efforts.

We acknowledge funding from the Swedish Knut and Alice Wallenberg Foundation (KAW 2005-0121) and from the Belgian Big Science program of the FWO (Research Foundation Flanders) and the Research Council

K.U. Leuven.

We acknowledge as well the receipt of fellowships from the CATHI Marie Curie Initial Training Network: EU-FP7-PEOPLE-2010-ITN Project number 264330.

Finally, many thanks to the CERN management for the continuous support to the HIE ISOLDE project.

## REFERENCES

- [1] M. Pasini, et al, "A SC upgrade for the REX-ISOLDE accelerator at CERN," Proceedings of LINAC08, Victoria, BC, Canada (2008).
- [2] W. Venturini Delsolaro et al. "Status of the HIE ISOLDE Linac", Proceedings of LINAC14, Geneva, Switzerland (2014).
- [3] Y. Kadi et al, "Status of the HIE ISOLDE project" HIAT2015, Yokohama, Japan (2015).
- [4] W. Venturini Delsolaro et al, "Nb Sputtered Quarter Wave Resonator for HIE ISOLDE", Proceedings of SRF2103, Paris, France (2013).
- [5] P. Zhang et al., "Frequency pre-tuning of the niobium sputtered quarter wave resonator for HIE ISOLDE project at CERN", NIMA 797 (2015) 101-109.
- [6] K. Artoos, et al, "Development of SRF cavity tuners for CERN", in these proceedings.
- [7] M. Therasse et al., "Series Superconducting Cavity Production for the HIE-ISOLDE Project at CERN," in Proceedings of LINAC2014, Geneva, Switzerland (2014).
- [8] B. Bartova, "Characterization of Nb Coating in HIE-ISOLDE QWR Superconducting Accelerating Cavities by means of SEM-FIB and TEM", WEPHA022, proceedings of IPAC'15, Richmond, VA, USA (2015).
- [9] P. Zhang et al. "The influence of cool down conditions at transition temperature on the quality factor of niobium sputtered quarter wave resonators for HIE ISOLDE" , in these proceedings.
- [10] Y. Leclercq et al, Proceedings of IPAC 2015, Richmond, VA, USA (2015).
- [11] M. Therasse et al. "First HIE-ISOLDE Cryo-module Assembly at CERN", these proceedings.
- [12] N. Delruelle et al, "Commissioning of the helium cryogenic system for the HIE-ISOLDE accelerator upgrade at CERN", Proceedings of CEC-ICMC 2015, Tucson, Arizona, USA (2015).
- [13] CERN internal report, EDMS 1537439.
- [14] L. Valdarno et al., "Thermal Design and Performance results of the first High-Beta Cryo-module for HIE-ISOLDE at CERN", Proceedings of CEC-ICMC15, Tucson, Arizona, USA (2015).
- [15] J-C. Gayde, G. Kautzmann et al, "HIE-ISOLDE Alignment and Monitoring System Technical Design and Project Status", IWAA2012, Chicago (2012).
- [16] G. Kautzmann, J-C. Gayde et al, "HIE-ISOLDE – General presentation of MATHILDE", IWAA2014, Beijing (2014).
- [17] BCAM, <http://alignment.hep.brandeis.edu>
- [18] P. Zhang et al., "The multipacting study of niobium sputtered high-beta quarter-wave resonators for HIE-ISOLDE," in these proceedings.