



CERN-ACC-2016-0106

Benjamin.bradu@cern.ch

Report

Beam screen cryogenic control improvements for the LHC run 2

B. Bradu, E. Rogez, E. Blanco-Viñuela, G. Ferlin, A. Tovar-Gonzalez

European Organization for Nuclear Research (CERN), Geneva 23, Switzerland

Keywords: CERN LHC, cryogenics, beam screens, feed-forward, controls, PLC.

Abstract

This paper presents the improvements made on the cryogenic control system for the LHC beam screens. The regulation objective is to maintain an acceptable temperature range around 20 K which simultaneously ensures a good LHC beam vacuum and limits cryogenic heat loads. In total, through the 27 km of the LHC machine, there are 485 regulation loops affected by beam disturbances. Due to the increase of the LHC performance during Run 2, standard PID controllers cannot keep the temperature transients of the beam screens within desired limits. Several alternative control techniques have been studied and validated using dynamic simulation and then deployed on the LHC cryogenic control system in 2015. The main contribution is the addition of a feed-forward control in order to compensate the beam effects on the beam screen temperature based on the main beam parameters of the machine in real time.

Presented at:

The 26th International Cryogenic Engineering Conference

New-Delhi, India
March, 2016

CERN-ACC-2016-0106
16/08/2016



Beam screen cryogenic control improvements for the LHC run 2

B. Bradu, E. Rogez, E. Blanco-Viñuela, G. Ferlin, A. Tovar-Gonzalez

European Organization for Nuclear Research (CERN), Geneva 23, Switzerland

E-mail: benjamin.bradu@cern.ch

Abstract.

This paper presents the improvements made on the cryogenic control system for the LHC beam screens. The regulation objective is to maintain an acceptable temperature range around 20 K which simultaneously ensures a good LHC beam vacuum and limits cryogenic heat loads. In total, through the 27 km of the LHC machine, there are 485 regulation loops affected by beam disturbances. Due to the increase of the LHC performance during Run 2, standard PID controllers cannot keep the temperature transients of the beam screens within desired limits. Several alternative control techniques have been studied and validated using dynamic simulation and then deployed on the LHC cryogenic control system in 2015. The main contribution is the addition of a feed-forward control in order to compensate the beam effects on the beam screen temperature based on the main beam parameters of the machine in real time.

1. Introduction

To maintain a good vacuum in the LHC (Large Hadron Collider) beam pipe and to limit heat loads to the 1.9 K pumping unit, it is necessary to keep a stable beam screen temperature around 20 K all the time, including beam injection and current ramping of superconducting magnets [1]. During LHC Run 1 (2010-2012), the beam screen heat loads were comparatively low and the conventional PID (Proportional Integral Derivative) controllers were able to manage the transients correctly. In LHC Run 2 (2015-2018) the beam induced heat loads are much more significant due to the shorter bunch spacing and due to the increase of energy and intensity of the beams [2]. When these heat loads become too large, the conventional PID control loops are not fast enough to compensate the temperature overshoot and to limit the helium consumption, mainly because of the significant delays in the cryogenic systems. In order to fix this problem, a feed-forward action has been developed and deployed over the LHC in 2015 on the different involved actuators to anticipate the beam effects on the beam screen temperatures in real-time.

2. Beam screen and cryoplant constraints

2.1. Beam screen circuit constraints

The temperature limits of the beam screen are defined to avoid thermo-hydraulic oscillations along the pipe, to maintain good vacuum of the beam tube, to thermalize the current leads of the corrector magnets and to reduce beam-induced heat loads to the cold mass [1]. The minimum temperature is established between 6 K and 13 K , depending on the flow, to avoid thermo-hydraulic oscillations and the maximum allowed temperature is 40 K for 30 minutes to ensure

an ultra high vacuum condition, otherwise, a beam dump is triggered. Nominal temperatures and pressures are described in Figure 1 for an arc half-cell of 53 *m* which is repeated 485 times over the whole LHC ring.

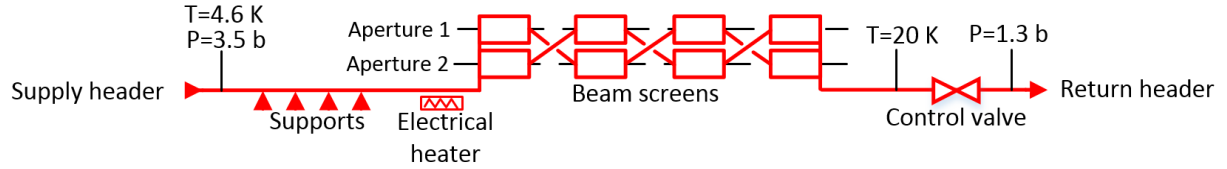

Figure 1. Beam screen cooling scheme (half-cell of 53 meters in arc)

2.2. Helium refrigerator constraints

The first constraint is that the non-isothermal refrigeration capacity between 4.6 *K* and 20 *K* is shared between the 1.8 *K* refrigeration unit and the beam screen circuits. Since the LHC machine shows lower thermal loads at 1.8 *K* than expected [3], a configuration with two 4.5 *K* refrigerators and one 1.8 *K* unit running together for two sectors is used as shown in Figure 2.

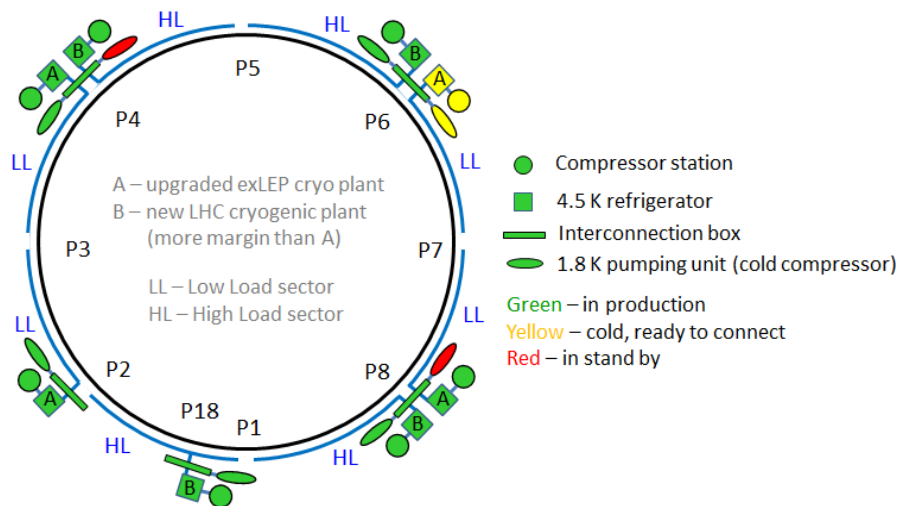

Figure 2. operation scenario of the 2015 run

A cooling margin is then created for the beam screens with the reduction of the flow for the 1.8 *K* unit and the new cooling capacity is now estimated to about 160 *W* per half-cell (compared to the installed capacity of 116 *W* per half-cell). Nevertheless, in 2015, the non-standard configuration of the plants at the P18 and P2 and a serious internal helium leak in refrigerator B at P8 highlighted a maximum cooling capacity of 145 *W*, 130 *W* and 130 *W* respectively per half-cell. Sealing of the leak at P8 and the preparation of a new configuration of the refrigerators at P18 and P2 have been made during the 2015 year-end technical stop to fulfil the estimation of 160 *W* per half-cell for the 2016 run.

The cooling capacity of the refrigerator is influenced by the cold gas return temperature and by the supercritical outlet line pressure going to the LHC tunnel. The optimal return temperature for the refrigerator is about 20 *K* and the optimal supercritical outlet pressure is 3.5 *bar*, determined by the hydrostatic pressure of the vertical line and by the distribution

pipng all along the LHC tunnel. Those two parameters are also influenced by the beam screen cooling circuits in the LHC tunnel and it is then necessary that these parameters do not vary during the operation to ensure the full capacity of the refrigerators.

Several parameters in the refrigerators can be used to adjust the refrigeration power delivered to the LHC: the high pressure, the turbine power and the cold box phase separator (thermal buffer). Nevertheless, the time constants of these parameters are not necessarily compatible with the beam dynamic heat loads as summarized in Table 1. The high pressure is the most important parameter and it is currently used to maintain the phase separator level and thus the refrigeration power is automatically adapted to the load, however this action only works for slow dynamics (\approx hours) [4]. In order to anticipate the beam induced heat loads, cryogenic operators are setting a dummy load of about 1.5 kW in the cold box phase separator to 'preload' the refrigerator and then this dummy load is switched off when the beam heat load arrives. About the turbine power, it is not automatically adapted to modify the refrigeration power as it is a refrigerator critical parameter but this could be considered in future if necessary.

Table 1. Time constants for refrigerators and beam dynamics

Parameters	Time constant
Refrigerator high pressure	≈ 1 hour
Refrigerator turbine power	≈ 20 min
Thermal buffer stored in the cold-box phase separator	≈ 2 min
Beam injection	≈ 10 min
Beam dump	≈ 2 min

3. LHC beam screen control scheme

The beam screen control scheme is composed of two independent regulation loops using two PID controllers as depicted in Figure 3. First, an inlet temperature controller (*TC847*) allows helium to be above 13 K at the entrance of the beam screens in order to avoid thermal-induced instabilities [5]. To achieve this task, an electrical heater (*EH847*) is used to warm-up helium at the entrance. Then, an outlet temperature controller (*TC947*) ensures the outlet temperature of the beam screen below 20 K by changing the mass-flow in the cooling circuit using a control valve (*CV947*). Note also that this control valve must be opened at a minimum position of 13 % to ensure a minimum flow in the beam screens in order to avoid thermal-induced instabilities when the heat load is low.

During LHC Run 1, the inlet temperature set-point was maintained at 13 K and the outlet temperature set-point at 17 K to avoid overshoot above the 20 K limit during beam injection. Results were satisfactory in most of the machine because the heat load induced by the beams was relatively low, around 10 W per half-cell of 53 m for the 2 apertures. Nevertheless, some unexpected extra heat loads were observed in the Inner Triplets, up to 100 W per half-cell. In this case, PID controllers show limitations during the transients and temperature overshoots were very high, up to 30 K, provoking beam dumps. One of the main reasons of the big overshoot is the significant delay and time constant between the outlet temperature and the valve action (delay of 5 min and 15 min of time constant). In this case the PID controller is not suitable to reject the beam disturbance in an efficient way. Consequently, several control improvements have been foreseen for LHC Run 2 to avoid such overshoots when the heat loads will be significantly increased due to beam intensities and energies.

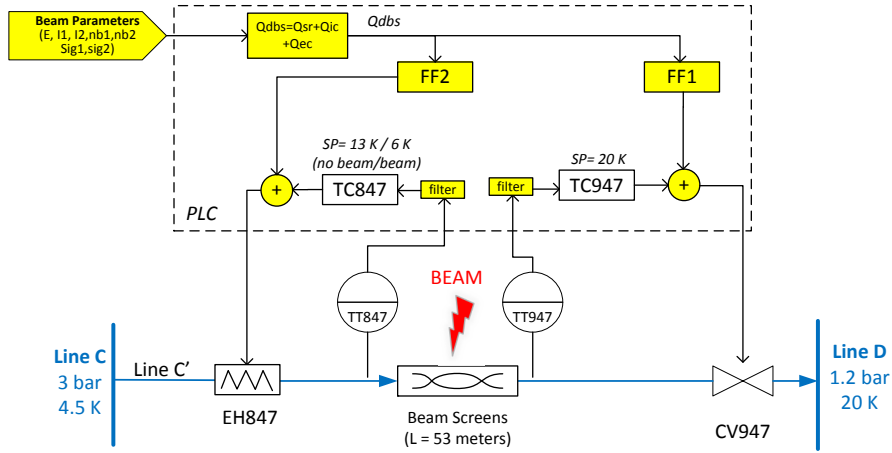

Figure 3. Beam screens control scheme. Yellow elements have been added for LHC Run 2

3.1. Control scheme evolution

The beam screen control scheme has been upgraded during Long Shutdown 1 (LS1) in 2013-2014 to solve the different issues, see Figure 3 where all yellow boxes are the improved features regarding the original control scheme:

- All inlet and outlet temperature sensors are filtered in the PLC (Programmable Logic Controller) to remove the noise.
- The set-point of the inlet temperature controller $TC847$ is automatically adapted according to the machine status. When there is no beam, the set-point is still 13 K to avoid thermal instabilities but when a beam is present, the set-point is lowered to 6 K because there is more mass-flow in this case, and there is no risk of thermal instabilities. This allows to preserve refrigeration power as helium will be less heated at the beam screen inlet.
- The deposited beam screen heat load Q_{dbs} is estimated in real-time within the PLC, directly from the beam parameters (energy, intensities, bunch numbers and mean bunch length), see [6] for details.
- Two feed-forward actions are added on the electrical heater and on the valve based on the estimation of the deposited beam screen heat load. As the delay between the beam and its effects on the beam screen outlet temperature is of the same order of magnitude as the effect of the valve action (around 5 minutes), this feed-forward action allows actuators to cancel the load before the temperature overshoot happens. This feed-forward architecture is optimal as all possible actuators are used to compensate the heat loads.

3.2. Feed-forward design

The dynamics of the beam screen outlet temperature can be expressed as the sum of two contributions coming from the valve and from the beam heat load (heater is neglected here):

$$TT_{947} = P \cdot CV_{947} + D \cdot Q_{dbs} \quad (1)$$

where $P = \frac{K \cdot e^{-\tau \cdot s}}{1 + T \cdot s}$ and $D = \frac{K_d \cdot e^{-\tau_d \cdot s}}{1 + T_d \cdot s}$ are first order transfer functions of the valve and of the beam heat load regarding the beam screen outlet temperature, see Table 2. After expansion

with the PID regulation loop and the feed-forward action we obtain:

$$TT_{947} = P \cdot TC_{947} \cdot e + P \cdot FF_1 \cdot Q_{dbs} + D \cdot Q_{dbs} \quad (2)$$

where e is the error between the set-point and the outlet temperature. As we want to delete the beam contribution on the final temperature, we have to setup the feed-forward transfer function such that:

$$FF_1 = -D \cdot P^{-1} \quad (3)$$

Applying this formula on our use case we obtain:

$$FF_1 = -\frac{K_d}{K} \cdot \frac{(1 + T \cdot s) \cdot e^{(\tau - \tau_d) \cdot s}}{(1 + T_d \cdot s)} \quad (4)$$

After having performed several identifications on the real beam screen regulation loops at the beginning of 2015, the different parameters have been found and are summarized in Table 2 for an arc cell. In our case, $\tau \approx \tau_d$ and as a smooth first order response is desired, the zero at the numerator can be deleted. Finally, the feed-forward transfer function can be then simplified such that:

$$FF_1 \approx -\frac{(K_d/K)}{(1 + T_d \cdot s)} \quad (5)$$

Table 2. Result of parameter identification on a beam screen arc cell.

K valve gain	T (s) valve time constant	τ (s) valve delay	K_d beam gain	T_d (s) beam time constant	τ_d (s) beam delay
-0.8	960	300	0.2	40	250

This feed-forward transfer function is easily implemented in the PLC. Operators can also tune this feed-forward action easily during the run as the gain K_d/K corresponds to the additional aperture on the valve needed to compensate 1 W of heat load and the time constant T_d represents the settling time of this compensation. The same approach can be applied on the heater in order to compensate the beam heat load and stabilize the refrigeration power.

4. Control validation using dynamic simulations

In order to validate this improved control scheme, dynamic simulations have been performed using an existing one dimension model of the LHC beam screen cooling circuit with the modelling and simulation software EcosimPro [7]. First, the model has been validated on several sets of experimental data obtained during LHC Run 1 and then, simulations have been made to compare different control strategies with the maximum expected beam screen heat loads in an arc half-cell (about 130 W per half-cell, compared to only 10 W observed during Run 1). Figure 4 shows the results obtained in simulation for three different control strategies applied in a standard arc half-cell of 53 m:

- *PI alone*: the inlet and outlet temperatures are controlled with classic PI controllers and set-points are constant.

- *PI+jump*: at the injection, a ‘jump’ to 30 % is applied on the controlled valve to anticipate the overshoot. This simple technique was already used during Run 1 in the Inner Triplets to avoid excessive temperatures during the beam injection but this jump has to be scaled manually at each injection according to a manual forecast of the heat load for the coming injection. The inlet temperature set-point is also decreased to 6 K at injection to avoid the extra heating on the heater.
- *PI+FF*: the feed-forward action is applied on the valve and on the heater as described in the previous section.

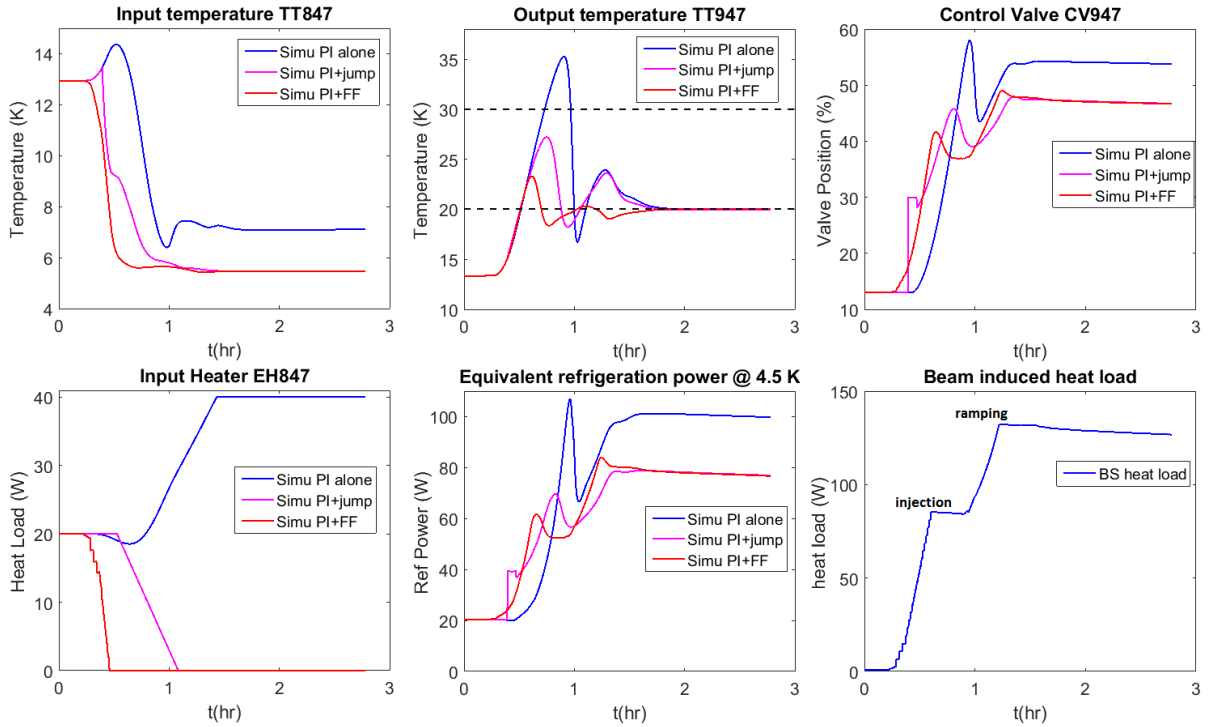

Figure 4. Simulations of arc beam screen temperatures and actuators for different control strategies during a beam injection producing 130 W in the half-cell.

The different simulations demonstrate that the feed-forward strategy can be applied successfully on the valve to reduce the temperature overshoot by anticipating the heat load effects. Moreover, the feed-forward action on the heater minimizes helium consumption by quickly shutting-off the heater at the entrance when the beam is imminent. Classical PI feedback loops are of course still necessary after injection to adjust the temperature to the desired set-point when the steady state is reached.

Note that all these feed-forward actions are efficient if the beam screen heat load Q_{dbs} is estimated correctly from beam parameters. In the case of the LHC, it is computed as the sum of three contributions: synchrotron radiation, image current and electron cloud. The two first contributions can easily be estimated from theoretical equations [2], but the electron cloud term is very difficult to predict and it can vary significantly along the machine as it depends on the beam screen surface cleaning. Consequently, the electron cloud contribution is computed as proportional to the beam energy and to the beam intensity and it is then scaled by operators using scaling parameters for each LHC sector in order to get a good match between the estimate and the measurements [6].

5. Results obtained during LHC Run 2 in 2015

This improved control scheme has been incrementally deployed in the 485 beam screen cooling loops along the LHC according to the machine operation and beam screen heat load observations. During 2015, the measured heat loads were much higher than expected because the 25 ns bunch spacing generated much more electron clouds. The beam screen heat load was originally set at 85 W per half-cell in the LHC design report (after scrubbing) [8] whereas an average of 145 W was measured in some sectors. The improvements of the control scheme were then very useful to allow the LHC to ramp-up to $2.7 \cdot 10^{14}$ protons per beam (*i.e.* 2244 bunches per beam) at the end of 2015.

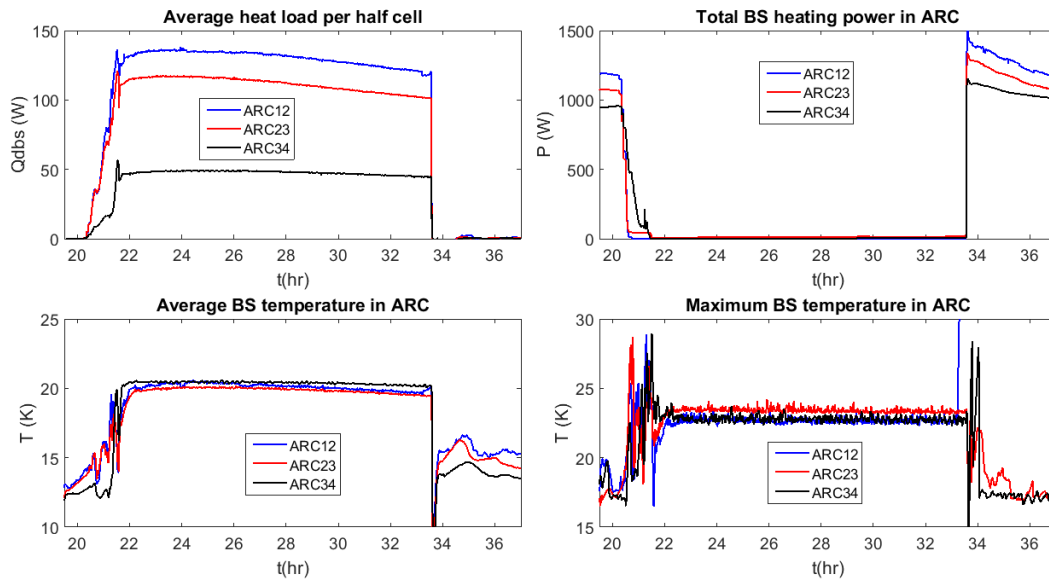

Figure 5. Measurements of LHC beam screen temperatures and heaters using the improved control scheme in November 2015 (LHC fill #4569 with 2244 bunches at 6.5 TeV per beam).

Figure 5 shows the results obtained with the feed-forward actions on three LHC sectors in November 2015 where the beam screen outlet temperatures were correctly controlled around 20 K in all sectors during the beam injection and during the energy ramping. It is noticed that the beam screen heat loads are highly variable along the machine, up to 135 W per half-cell in average in arc12, less than 48 W in arc34 and locally up to 210 W in some half-cells. This explains why some beam screens reached 28 K, but for some minutes, which is still not an issue for the machine as it remains below 30 K for a short period. Concerning refrigeration power, the cycle is optimized as the average temperature respects the set-point of 20 K and as all the heating power is immediately cancelled at the injection due to the feed-forward action on the heater and it is restored without major overshoot at the beam dump.

6. Conclusion

During Run 1 of the LHC, the beam screen heat loads were limited and classical PI controllers were sufficient to maintain a good temperature along the machine. Due to the reduction of the bunch spacing to 25 ns for LHC Run 2 in 2015, the beam screen heat loads increased significantly and the PI controllers were not able to maintain the temperature in good ranges during the fast transients. As a consequence the helium consumption for the beam screens was higher than the available refrigerator capacity during these transients.

To cope with the different cryoplant constraints and with accelerator constraints, the beam screen control scheme was improved, by adding two feed-forward actions on the valve and on the heater to anticipate the beam effects. To do so, the beam screen heat loads are estimated inside the PLC in real-time based on the beam parameters (beam intensity, number of bunches, etc.). Then, the valve and the heater are quickly positioned to their expected position based on the forecasted beam heat load and the PI controllers are still regulating in parallel to adjust the temperatures to the desired set-points.

In order to design, validate and tune this new control scheme, many dynamic simulations were made with an existing model of the cryogenic beam screen circuits in Ecosimpro. Once this new approach was validated in simulation, it was deployed in the 485 regulations loops along the LHC during 2015 and tuned with the beams. Finally, this new control scheme allows the cryogenic control system to smoothly manage the transients as expected and the LHC was able to run with 2244 bunches at 6.5 *TeV* where the cryoplants begin to run almost at their full capacity.

In the future, a significant effort will be made to have the best possible heat load estimation in order to minimize the refrigeration power for the beam screens, as well as to run the refrigerators at a constant power.

Acknowledgments

The authors would like to thank Borja Fernandez for his help on incorporating the beam information in the cryogenic control system, Przemyslaw Plutecki for his help to generate all control modifications and Giovanni Iadarola who collaborated with us to establish a new electron cloud induced heat load estimation. Thanks also to the cryogenics operation team for the tuning of the loops and to the LHC beam operation team for their help.

References

- [1] Baglin V, Lebrun P, Tavian L and van Weelderden R 2012 *Cryogenic Beam Screens for High-Energy Particle Accelerators* (24th Int. Cryogenic Eng. Conf., Fukuoka, Japan)
- [2] Tavian L 2012 *Performance limitations of the LHC cryogenics: 2012 review and 2015 outlook* (LHC Beam Operation workshop, Evian, France)
- [3] Brodzinski K, Claudet S, Ferlin G and Tavian L 2014 *LHC Cryogenics - perspectives for run 2 operation* (Evian workshop, Evian, France)
- [4] Bradu B, Gayet P and Niculescu S I 2009 *Control optimization of a LHC 18 kW cryoplant warm compression station using dynamic simulation* (Cryogenic Engineering Conference, Tucson, USA)
- [5] Hatchadourian E, Lebrun P and Tavian L 1998 *Supercritical Helium Cooling of the LHC Beam Screens* (17th Int. Cryogenic Eng. Conf., Bournemouth, UK)
- [6] Bradu B, Rogez E, Iadarola G, Blanco E, Ferlin G and Tovar A 2016 *Compensation of Beam Induced Effects in LHC Cryogenic Systems* (7th Int. Part. Accel. Conf., Busan, South Korea)
- [7] Bradu B, Blanco E and Gayet P 2013 *Cryogenics* **53** 45
- [8] Bruning O, Collier P, Lebrun P, Myers S, Ostojic R, Poole J and Proudlock P 2004 *LHC Design Report* (CERN, Geneva)