



BEAM-LOADING EFFECT ON BREAKDOWN RATE IN HIGH-GRADIENT ACCELERATING STRUCTURES

Frank Tecker¹, Theodoros Argyropoulos^{1,2}, Nuria Catalan Lasheras¹, Roberto Corsini¹,
Alberto Degiovanni^{1,3}, Davide Gamba^{1,4}, Jorge Ginger Navarro^{1,2}, Alexej Grudiev¹,
Gerard McMonagle¹, Jose Luis Navarro Quirante^{1,3}, Robin Rajamaki^{1,5}, Eugenio Senes^{1,7},
Igor Syratcev¹, Joseph Tagg⁶, Benjamin Woolley¹, Walter Wuensch¹

¹CERN, Geneva, Switzerland

²IFIC (CSIC-UV), Valencia, Spain

³ADAM, Geneva, Switzerland

⁴John Adams Institute, Oxford, United Kingdom

⁵Aalto University, Espoo, Finland

⁶National Instruments Switzerland, Ennetbaden, Switzerland

⁷University of Torino, Torino, Italy

Abstract

The CLIC Test Facility CTF3 was built, commissioned and operated at CERN by an international collaboration, with the aim of validating the CLIC two beam acceleration scheme, in which the RF power used to accelerate e^+/e^- beams is extracted from a high intensity electron beam. In the past years the main issues of such a scheme were assessed, demonstrating its feasibility. The CTF3 experimental programme is complementing these results by addressing cost and performance subjects, mainly using the CALIFES test beam injector and a full scale two-beam module. In this paper we document the present status and give an outlook to next year run, when the experimental programme should be completed.

7th International Particle Accelerator Conference, Busan, Korea, 8 - 13 May 2016

Geneva, Switzerland

12 May 2016

BEAM-LOADING EFFECT ON BREAKDOWN RATE IN HIGH-GRADIENT ACCELERATING STRUCTURES*

F. Tecker[†], N. Catalan-Lasheras, R. Corsini, A. Degiovanni¹, A. Grudiev, G. McMonagle, J.L. Navarro Quirante¹, I. Syratchev, W. Wuensch, B. Woolley, CERN, Geneva, Switzerland
 R. Rajamaki², Aalto University, Espoo, Finland
 T. Argyropoulos², J. Giner-Navarro², IFIC (CSIC-UV), Valencia, Spain
 D. Gamba², JAI, Oxford, United Kingdom
 J. Tagg, National Instruments Switzerland, Ennetbaden, Switzerland
 E. Senes², University of Torino, Torino, Italy
¹ present affiliation: ADAM, Geneva, Switzerland
² also at CERN, Geneva, Switzerland

Abstract

The Compact Linear Collider (CLIC) study for a future electron-positron collider with a centre-of-mass energy up to 3 TeV aims for an accelerating gradient of 100 MV/m. The gradient is limited by Radio Frequency (RF) breakdowns, and the luminosity requirements impose a limit on the admissible RF breakdown rate. RF testing of 12 GHz structure prototypes has shown that gradients in excess of 100 MV/m can be reached with the required breakdown rate. However at CLIC, the structures will be operated with significant beam-loading, modifying the field distribution inside. The effect of the beam-loading must be well understood but has not been previously measured. The commissioning and operation of an experiment to measure the effect of beam-loading on breakdown rate and the measurement results are presented.

INTRODUCTION

The CLIC project [1] aims to collide electrons and positrons accelerated in two opposing linacs using normal-conducting high-gradient accelerating structures. A major limitation for the achievable gradient is the RF breakdown (BD) effect which causes luminosity loss due to the transverse kick on the beam. A maximum breakdown rate (BDR) of $3 \cdot 10^{-7}$ BD/(pulse-m) is specified for a 3 TeV CLIC at the nominal average gradient of 100 MV/m in order to limit luminosity loss due to this effect to less than 1%. An extensive program has been carried out to understand and control the RF breakdown rate in prototype CLIC accelerating structures. Results demonstrate that such low breakdown rates are achievable [2]. All breakdown high-gradient tests so far have been performed without any beam inside the structure. CLIC is designed for a high RF-to-beam efficiency of around 30%. This high level of beam loading is accomplished with a high beam current of approximately 1A, unavoidably modifying the longitudinal field profile. The input power to the structure needs to be increased accordingly to maintain the same average field inside the structure.

The effect of the field profile change on the breakdown behaviour is hard to predict. The whole-structure breakdown rate varies approximately with electric field as E_{acc}^{30} when input power is varied [2], while the longitudinal dependency of the breakdown rate with the surface electric field is approximately linear [3]. In order to experimentally measure the effect of beam loading on breakdown rate, an experiment is running at the CLIC test facility CTF3 [1] using a 12 GHz klystron connected to a CLIC prototype accelerating structure loaded by the CTF3 beam. Any advances in understanding this effect are of general interest not only for the CLIC collaboration but for the high-gradient community in general.

EXPERIMENT LAYOUT

In CTF3, a dogleg line that branches off midway along the drive beam linac transports the CTF3 drive beam to a CLIC prototype accelerating structure connected to a 12 GHz RF source. The basic layout of the experimental setup is shown in Fig. 1.

The beam optics inside the dogleg line has been designed to provide minimum beam size and maximum transmission

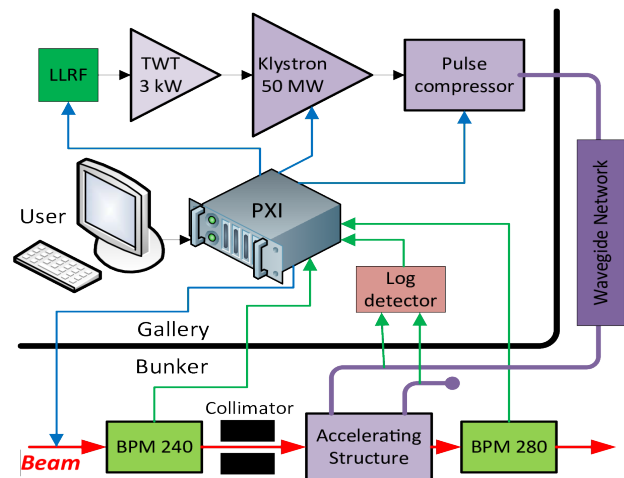

Figure 1: Simplified scheme of the hardware installation, control and acquisition system.

* Funding for accelerating structure provided by the Swiss National Science Foundation Grant 135012.

[†] tecker@cern.ch

through the structure under test [4]. A spectrometer and a screen installed further down the linac allow to measure energy and Twiss parameters of the beam by a quadrupole scan. The transmitted beam has a current of 1.2 A-1.6 A, with a pulse length up to 250 ns and an energy up to 130 MeV with a pulse repetition frequency up to 50 Hz.

The 12 GHz installation [5] consists of a klystron, RF pulse compressor and the RF network to transport the RF to the structure. The LLRF is pre-amplified by a 3 kW TWT before injecting it to the klystron. The klystron is capable of producing 50 MW of 12 GHz RF pulses of 1.5 μ s at 50 Hz repetition rate [6] driven by a Scandinova solid state modulator [7]. The SLED I type pulse compressor is able to compress the klystron output into a 250 ns 140 MW pulse [8]. The RF is transported through an overmoded waveguides and components system. The forward, reflected and transmitted RF power is detected at directional couplers close to the structure and measured by logarithmic detectors. Two Beam Position Monitors (BPMs) located up- and downstream the structure measure the beam current sent through.

A National Instruments PXIe-8133 controller equipped with high-performance NI FlexRIO FPGA-based digitizers (NI 5761 – 250MS/s – 4ch) [9] does the power signal reading and interlocking complemented with serial buses, digital IO and the CERN control system, all controlled and interfaced to the user with an adapted version of the Labview program used in the test stand [10]. The acquisition system checks all signals pulse-to-pulse and stores events periodically as well as breakdown-like events based on conservative trigger criteria where only ~10% of the events passing it are real breakdowns. The breakdown identification is based on the observation of the increase of reflected RF power and the loss of transmitted signal through the structure compared to the incident pulse [11]. The stored breakdown events use a buffer which contains the two previous pulses in addition to the breakdown pulse itself. This approach allows the breakdowns to be compared with normal events and to check for potential evidences of breakdown triggers.

EXPERIMENTAL RESULTS

A TD26CC CLIC structure prototype (tapered, damped, 26 cells, compact coupler) [12] was installed in the dogleg line in May 2015. This TD26CC had already been processed in 2013 during 6 months but was accidentally vented for few weeks at the testing place. It was re-baked out at 650°C before installing it for the beam-loading experiment. The structure needed to be reconditioned, and the conditioning speed was lower than in the 2013 experiment. The conditioning reached a saturation level, and no breakdown rate improvement was seen in the last 10⁸ pulses [13]. This saturation allows the comparison of long measurements at different gradients and configurations.

The breakdown rate for an RF pulse with the shape and pulse length of 180 ns of the nominal CLIC RF pulse was measured for different conditions – without beam and with a beam current of 1.6 A (Table 1).

This current is higher than the nominal CLIC current to increase the loading and to amplify an eventual effect on the BDR. In addition to the loaded case with acceleration, where the RF power is absorbed by the beam, the relative RF-to-beam phase was also modified to decelerate the beam, thus using the beam to produce RF power instead of absorbing it (anti-loaded). In this situation, the field rises along the length of the structure. The field profiles for the different cases are shown in Fig. 2.

When a BD takes place in the loaded case, typically the transmitted power slightly drops and rises again (see example in Fig. 3). This can be explained as the plasma formation starts reflecting power and cuts the transmission, but afterwards the beam-loading produces power downstream the BD location, which can raise to a higher level due to the high beam current of 1.6 A.

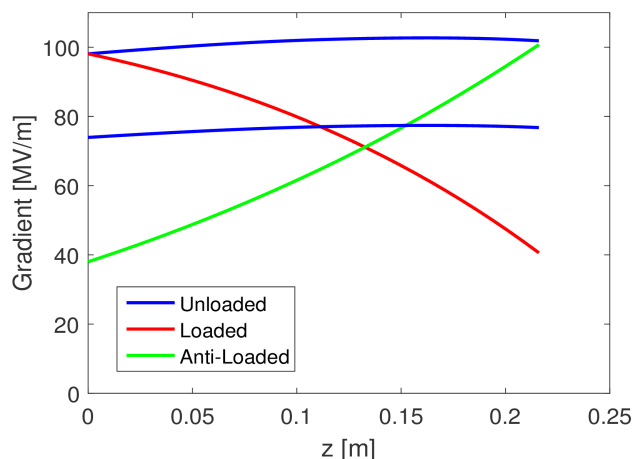

Figure 2: Longitudinal accelerating gradient profile for the CLIC structure under test unloaded (blue lines) at 43.3 MW and 24.6 MW input power, with 1.6 A of beam loaded (red line) at 43.3 MW and anti-loaded (green line) at 6.5 MW input power.

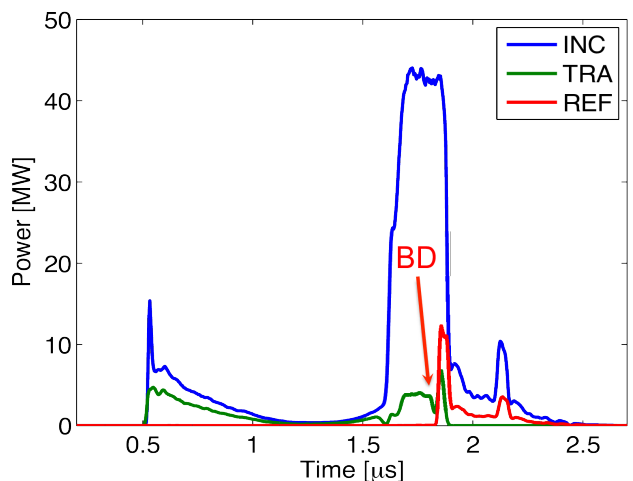

Figure 3: RF signals for a BD with beam-loading. The incident (blue), transmitted (green), and reflected power (red) are shown.

Table 1: Conditions for the Various Breakdown Rate Measurements and Breakdown Rate Results

Input power (MW)	Av./peak gradient (MV/m)	Loading	pulses	BDs	BDR (10^{-5} /pulse)
43.3	100/103	Unloaded	29796700	478	1.60 +/- 0.07
43.3	75/98	Loaded	11288100	192	1.70 +/- 0.12
6.5	66/100	Anti-Loaded	8112500	76	0.94 +/- 0.11
24.6	75/77	Unloaded	3672400	5	0.14 +/- 0.06

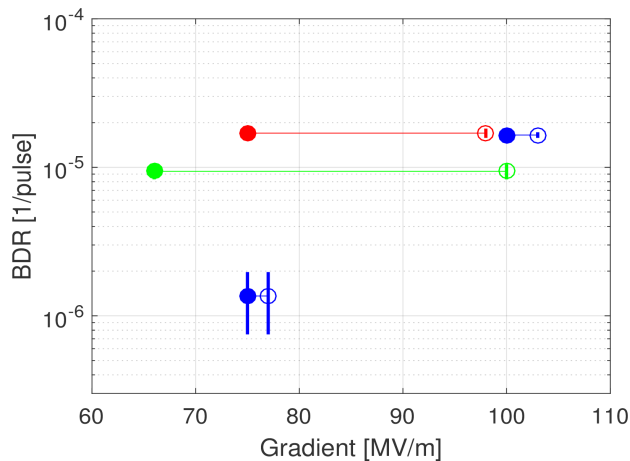

Figure 4: Breakdown rate for the loaded (red), unloaded (blue), and anti-loaded (green) cases at different gradient. The plot shows both average gradient (filled dots) and peak gradient (empty dots) for each case connected by a line. Only statistical errors are shown.

Table 1 and Fig. 4 show the breakdown rate for all measurements. The first observation is that the beam does not increase the breakdown rate.

The breakdown rate is similar for comparable peak gradients but a lower average gradient by loading or anti-loading does not improve the BDR. So the breakdown rate is correlated to the peak gradient inside the structure rather than to the average gradient.

Figure 5 shows breakdown cell distribution along the structure for the unloaded, loaded and anti-loaded case. While the breakdowns are present all along the structure in the unloaded case, the distribution clearly shifts to the region of higher fields for the loaded and anti-loaded case. This result further supports the hypothesis of a breakdown rate dominated by peak gradient rather than by the average gradient. More data needs to be collected to reduce statistical errors and confirm the results.

CONCLUSIONS

An experiment has started to measure the effect of beam loading on the breakdown rate of high-gradient accelerating structures. The first results show a breakdown rate dominated by the maximum peak gradient inside the accelerating structure rather than by the average gradient for all unloaded, loaded and anti-loaded cases. Breakdown cell distributions inside the structure support this conclusion. The beam presence does not seem to alter the breakdown

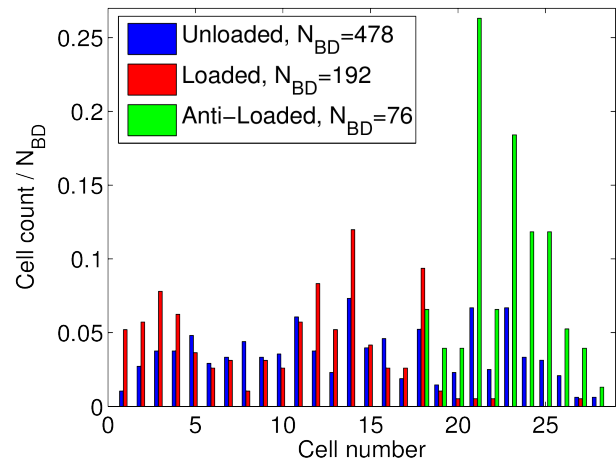

Figure 5: Breakdown cell distribution along the TD26CC structure for unloaded (blue), loaded (red) and anti-loaded (green) case.

rate for the statistics accumulated when the input power is kept constant. Further measurements will be carried out during the present year to draw further conclusions. If the results are confirmed, it means that it may be possible to optimise the structure tapering for the loaded, rather than the unloaded, field profile giving better performance under beam-loaded conditions.

ACKNOWLEDGMENTS

We would like to thank M. Kastriotou, A.G. Lee Bruton, A. Olyunin, E. Paju, H. Rambeau, P. Skowronski, A. Solodko, H. Vestergard and CERN PS and CTF operators for their invaluable help with structure drawings, technical work, installations and beam supervision.

REFERENCES

- [1] M. Aicheler *et al.* eds., "A Multi-TeV linear collider based on CLIC technology: CLIC Conceptual Design Report", CERN, Geneva, Switzerland, Rep. CERN-2012-007.
- [2] A. Grudiev, S. Calatroni, and W. Wuensch, "New local field quantity describing the high gradient limit of accelerating structures", in *Phys. Rev. ST Accel. Beams*, vol. 12, p. 102001, 2009 and Erratum-ibid, vol. 14, p. 099902, 2011.
- [3] W. Wuensch, "Status and objectives of the CLIC X-band activity", in *HG2012 ICFA mini workshop*, Tsukuba, Japan, <http://indico.cern.ch/event/165513>
- [4] F. Tecker *et al.*, "Experimental study of the effect of beam loading on RF breakdown rate in CLIC high-gradient accel-

- erating structures“, in *Proc. of IPAC'13*, Shanghai, China, paper TUPME054, p. 1691.
- [5] J. Kovermann *et al.*, “Commissioning of the first klystron-based X-Band power source at CERN“, in *Proc. of IPAC'12*, New Orleans, LA, USA, paper THPPC060, p. 3428.
- [6] D. Sprehn *et al.*, “A 12 GHz 50 MW klystron for support of accelerator research“, SLAC, Stanford, CA, USA, Rep. SLAC-PUB-14377.
- [7] Scandinova, <http://www.sc-nova.com/>
- [8] A.A. Bogdashov, “A 12 GHz pulse compressor and components for CLIC test stand“, in *Proc. of RuPAC'10*, Protvino, Russia, paper TUPSA005, p. 44.
- [9] National Instruments, <http://www.ni.com/>
- [10] N. Catalan-Lasheras *et al.*, “Experience operating an X-band high-power test stand at CERN“, in *Proc. of IPAC'14*, Dresden, Germany, paper WEPME016, p. 2288.
- [11] A. Degiovanni *et al.*, “Diagnostics and analysis techniques for high power X-band accelerating structures“, in *Proc. of Linac'14*, Geneva, Switzerland, paper TUPP029, p. 290.
- [12] A. Grudiev and W. Wuensch, “Design of the CLIC main linac accelerating structure for CLIC conceptual design report“, in *Proc. of Linac'10*, Tsukuba, Japan, paper MOP068, p. 211.
- [13] J. Giner Navarro *et al.*, “High-gradient structure performances: ongoing tests and summary“, in *Proc. of CLIC Workshop 2016*, Geneva, Switzerland.