

# BEAM INSTRUMENTATION PERFORMANCE DURING COMMISSIONING OF CERN'S LINAC-4 TO 50MeV AND 100MeV

Uli Raich, Thomas Hofmann, Federico Roncarolo, CERN, Geneva, Switzerland

## Abstract

Linac-4, a 160 MeV H<sup>+</sup> linear accelerator is designed to replace the aging 50 MeV proton Linac-2. It will consist of an H<sup>+</sup> source and 45 keV LEBT, an RFQ and 3 MeV MEBT with a chopper, 3 drift tube linac (DTL) tanks accelerating the beam to 12, 30 and 50 MeV, cavity coupled structures (CCDTL) accelerating it to 100 MeV and a pi mode structure (PIMS) bringing it to its design energy of 160 MeV. This paper reports on the commissioning of the DTL and CCDTL with 2 dedicated temporary measurement lines, the first one adapted to the 12 MeV beam while the second one is dedicated to characterize the 50 MeV and the 100 MeV beams. The beam diagnostic devices used in these lines are described as well as results obtained.

## 3 AND 12 MEV MEASUREMENT LINE

The Linac-4 accelerator is being assembled in stages. At each stage the beam is fully characterized, and the measurement results are compared to beam optics simulations. While many diagnostic devices are permanently installed in the machine and will be used for routine operation, dedicated temporary measurement lines were designed to determine beam characteristics after the RFQ at 3 MeV and after the first DTL tank at 12 MeV.

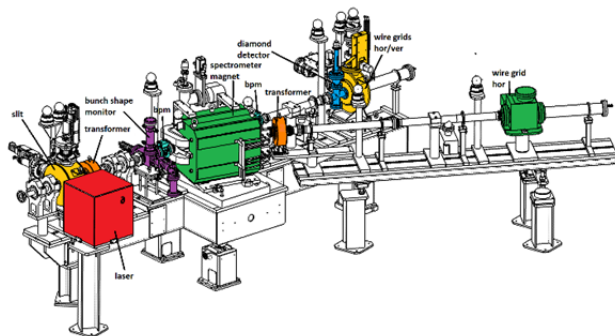

Figure 1: 3 and 12 MeV measurement line.

The following devices were installed on the 3 and 12 MeV measurement line:

- Slit/grid emittance meter [1] (yellow)
- 2 Beam Current Transformers (BCTs) (orange)
- 2 Beam Position Monitors (BPMs) (light blue)
- Spectrometer (green)
- Bunch shape monitor (violet)
- Laser emittance meter [2] (red) with a diamond detector (blue)

The BCTs were the first instruments to see the beam as it passed through the RFQ and the first DTL tank. They

have calibration windings into which a precise current is injected after each beam pulse, providing an absolute calibration. BCTs were extensively used to optimize transmission.

## Transverse Emittance

The slit/grid device directly measured the transverse phase-space with the results compared to simulation. Similar measurements were made with the laser emittance meter, where the laser acts as the slit, neutralizing a small part of the H<sup>+</sup> beam [3]. While the remaining H<sup>+</sup> beam was deflected into the spectrometer line, the angular distribution of the neutralized H<sup>0</sup>s were detected with a diamond detector. Good agreement was found between both measurement techniques, providing important input for understanding the initial phase space distribution of the beam.

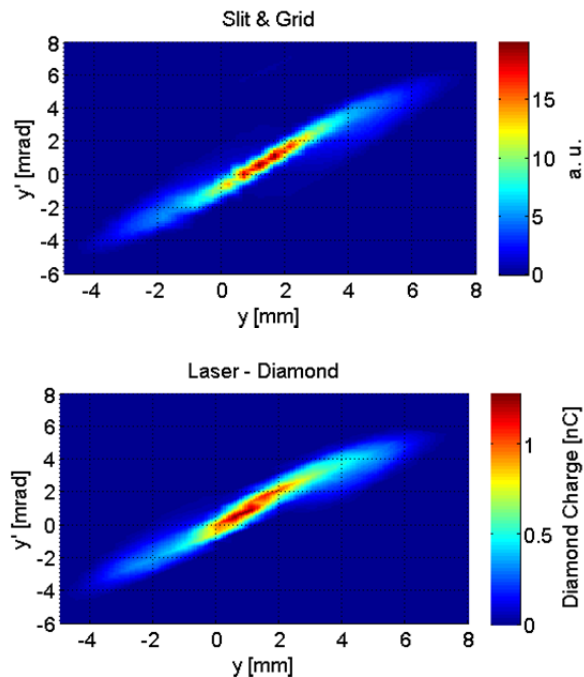

Figure 2: Phase space measured with slit/grid and laser emittance meter at 12 MeV.

## 50 AND 100 MEV MEASUREMENT LINE

Due to the energy-deposition in the slit, the slit/grid device could not be used at energies higher than 12 MeV. Equally the spectrometer could not handle higher energies because of the limited field in the spectrometer magnet.

For these reasons a different measurement line was designed for higher energies where the emittance was measured with 3 profile measurements and the average beam energy was measured using the time of flight between 2 BPMs used as phase probes.

The following devices were installed on the 50 and 100 MeV measurement line:

- 3 Profiler assemblies with horizontal and vertical wire grids and an L-shaped wire scanner
- 2 BPMs
- 1 BCT
- 1 laser profiler with a diamond detector
- 1 bunch shape monitor

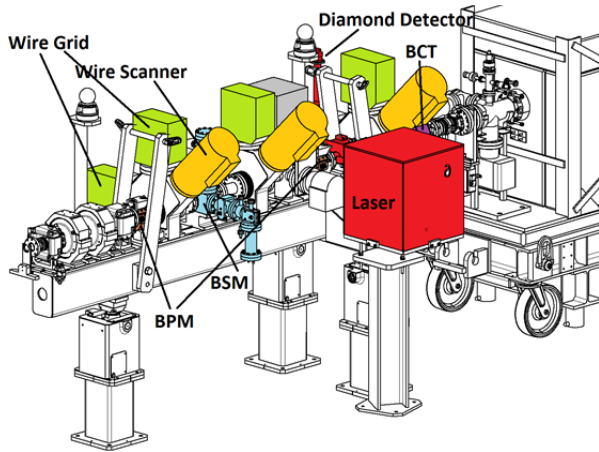

Figure 3: 50 and 100 MeV measurement line.

This measurement line was first installed after the third DTL tank at 50 MeV and was then moved to after the last CCDTL tank at 105 MeV.

### Adjusting RF Parameters with Transformers

To perform the first adjustment of the DTL RF phase, the transmission through the cavity was measured with a current transformer (Figure 4).

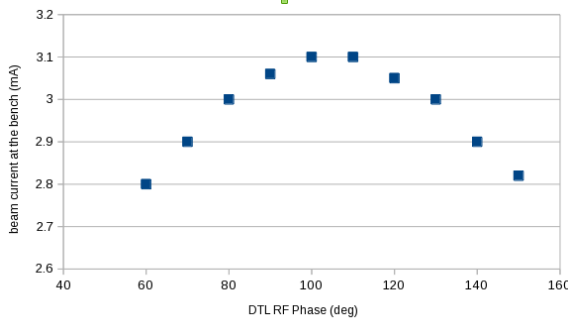

Figure 4: Beam intensity versus RF phase.

### Measuring Beam Energy with Time of Flight

Shorted strip line pick-ups are used as beam position monitors and are also able to measure the relative intensity of the beam and beam energy via time-of-flight between 2 BPMs.

The beam energy versus RF phase follows a characteristic curve for a given RF amplitude. These curves were calculated with simulation programs and compared to measurements, which allowed the correct RF settings to be determined. Figure 5 shows the theoretical values compared with measured values for DTL1. An excellent agreement can be seen, with the same method consequently applied for DTL2 and DTL3.

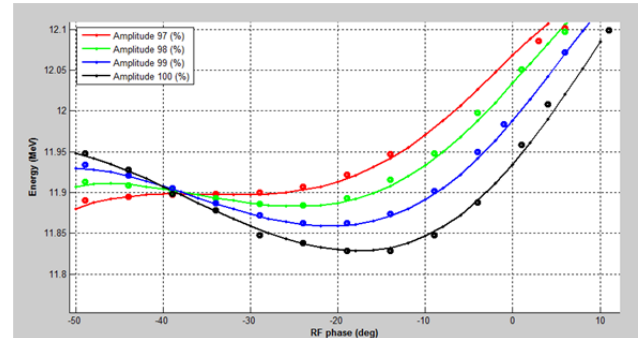

Figure 5: Beam energy versus DTL1 RF amplitude and phase (lines: simulated, points: measured).

### Comparison Between Wire Scanner and Wire Grids

When H<sup>-</sup> ions hit an intercepting wire of a profile grid electrons are stripped and can be captured by adjacent wires, thus producing cross talk between them.

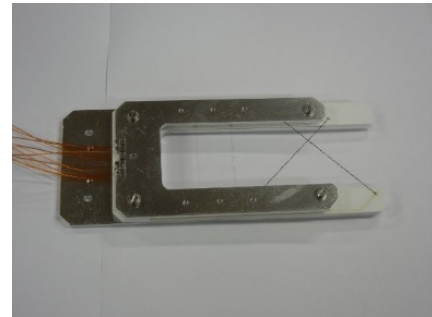

Figure 6: L-shaped wire scanner.

This effect can be nicely seen with L-shaped wire scanners where a small signal on the horizontal wire can be observed when the vertical wire intercepts the beam and vice versa.

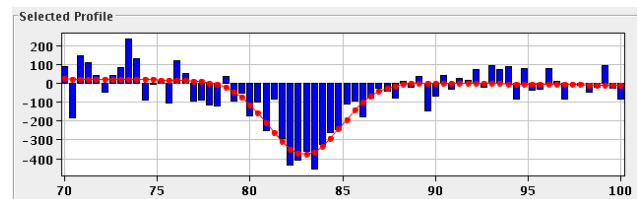

Figure 7: Signal seen on horizontal wire when the vertical wire intercepts the beam.

The amplitude of the crosstalk between wires corresponds to only a few thousandths of the real amplitude.

Comparing wire scanner profiles to profiles measured with wire grids a difference of ~1.5% in the calculated beam width is observed.

### Comparison Between Laser Wire and Wire Grid Profile

As can be seen in Figure 3, the laser wire was positioned between the second and third wire grid without any magnetic element in between. The electrons produced by laser stripping were extracted from the beam with a small dipole field and detected on a diamond detector. Moving the laser trough the beam and measuring the collected electron intensity for each laser position allowed the beam profile to be determined. A comparison of the normalized profiles measured by the wire grid and laser wire is shown in Fig 8, demonstrating excellent agreement.

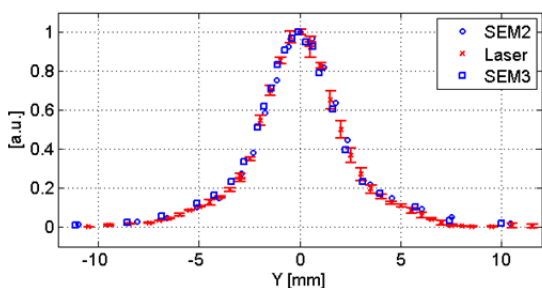

Figure 8: Scaled profiles from grids and laser.

### Transverse Emittance

Since direct phase space scanning is not possible at higher than 50 MeV the phase space parameters were determined through the measurement of three profiles around a beam waist.

The profiles had to be measured on one monitor at a time in order to avoid the influence of stripped electrons hitting a downstream detector. A standard linear calculation was not applicable in this case because of the strong influence of non-linear space charge effects.

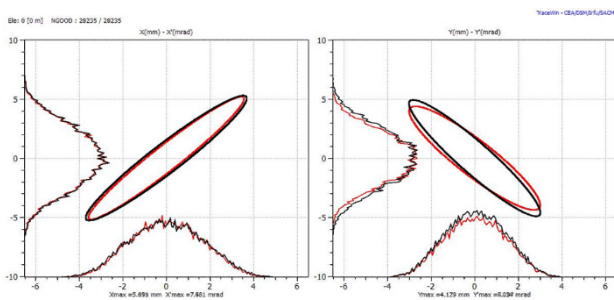

Figure 9: Emittance comparison measured (red) versus simulated (black).

The Twiss parameters determined by linear transformations are only used as a first estimation and serve as input for a multi-particle trajectory code (Travel) considering space charge. These initial Twiss parameters

are then modified within a given range until the resulting simulated profiles correspond to the measured ones [4].

The Twiss parameters determined by this method were found to perfectly fit those initially expected (Figure 9).

A similar method was used for the longitudinal emittance, varying RF parameters and measuring phase distributions with the bunch shape monitor [5].

## CONCLUSION

The Drift Tube structures of CERN’s new Linac-4 have been successfully commissioned with two dedicated beam diagnostic test benches. Comparison of emittance measurements made through direct phase space scanning with a slit/grid and a laser emittance meter show very good agreement. Emittance measurement at 50 MeV using three profile measurements combined with multi-particle, space charge dominated tracking code was shown to successfully reproduce the expected beam optics parameters.

The comparison between profiles measured with wire grids and wire scanners at the same position in the machine show differences of less than 2%, the residual discrepancy being within the expected tolerance.

It was also demonstrated that fine adjustment of RF parameters could be accomplished using the energy measured through the time of flight between two BPMs.

## ACKNOWLEDGEMENTS

Many thanks go to the members of the CERN BE/BI group for design and construction of the mechanics, electronics and software involved. Thanks also to the CERN BE/ABP group who supplied the simulation results and operated the machine during the measurements.

## REFERENCES

- [1] F. Zocca, E. Bravin, M. Duraffourg, G.J. Focker, U. Raich, and F. Roncarolo, “Profile and Emittance measurements at the CERN Linac-4 3 MeV Test Stand”, in *Proc. IBIC’13*, Oxford, UK, paper WEPF09, pp. 826-829.
- [2] T. Hofmann, G.E. Boorman, A. Bosco, E. Bravin, S.M. Gibson, K.O. Kruchinin, U. Raich, F. Roncarolo, and F. Zocca, “Experimental results of laserwire emittance scanner for Linac-4 at CERN”, *Nuclear Instruments and Methods Phys. Res. Section A*.
- [3] R. Roncarolo *et al.*, “Transverse Profile and Emittance Measurements during the CERN Linac-4 Commissioning at 3 and 12 MeV”, in *Proc. Linac’14*, Geneva, Switzerland, paper TUPP035.
- [4] J-B Lallement, A.M. Lombardi, P.A. Posocco, “CERN Linac4 Beam Commissioning Strategy”, in *Proc. HB’12*, Beijing, China, paper TU03B03, pp. 283-285.
- [5] G. Bellodi *et al.*, “Longitudinal beam profile measurements in Linac4 commissioning”, in *Proc. Linac’14*, Geneva, paper MOPP02, pp. 108-110.