

Status and Operation of the Linac4 Ion Source Prototypes

J. Lettry^{1, b)}, D. Aguglia¹, P. Andersson¹, S. Bertolo¹, A. Butterworth¹, Y. Coutron¹, A. Dallocchio¹, E. Chaudet¹, J. Gil-Flores¹, R. Guida¹, J. Hansen¹, A. Hatayama², I. Koszar¹, E. Mahner¹, C. Mastrostefano¹, S. Mathot¹, S. Mattei¹, Ø. Midttun¹, P. Moyret¹, D. Nisbet¹, K. Nishida², M. O'Neil¹, M. Ohta², M. Paoluzzi¹, C. Pasquino¹, H. Pereira¹, J. Rochez¹, J. Sanchez Alvarez¹, J. Sanchez Arias¹, R. Scrivens¹, T. Shibata², D. Steyaert¹, N. Thaus¹, T. Yamamoto²,

¹CERN, 1211 Geneva 23, Switzerland

²Graduate School of Science and Technology, Keio University, 3-14-1 Hiyoshi, Kohoku-ku, Yokohama 223-8522 Japan

Abstract

CERN's Linac4 45 kV H- ion sources prototypes are installed at a dedicated ion source test stand and in the Linac4 tunnel. The operation of the pulsed hydrogen injection, RF sustained plasma and pulsed high voltages are described. The first experimental results of two prototypes relying on 2MHz RF- plasma heating are presented. The plasma is ignited via capacitive coupling, and sustained by inductive coupling. The light emitted from the plasma is collected by viewports pointing to the plasma chamber wall in the middle of the RF solenoid and to the plasma chamber axis. Preliminary measurements of optical emission spectroscopy and photometry of the plasma have been performed. The design of a cesiated ion source is presented. The volume source has produced a 45 keV H- beam of 16-22 mA which has successfully been used for the commissioning of the Low Energy Beam Transport (LEBT), Radio Frequency Quadrupole (RFQ) accelerator and chopper of Linac4.

Presented at : 15th International Conference on Ion Sources ICIS13, 9-13 September 2013,
Chiba, Japan

Status and Operation of the Linac4 Ion Source Prototypes ^{a)}

J. Lettry^{1, b)}, D. Aguglia¹, P. Andersson¹, S. Bertolo¹, A. Butterworth¹, Y. Coutron¹, A. Dallochio¹, E. Chaudet¹, J. Gil-Flores¹, R. Guida¹, J. Hansen¹, A. Hatayama², I. Koszar¹, E. Mahner¹, C. Mastrostefano¹, S. Mathot¹, S. Mattei¹, Ø. Midttun¹, P. Moyret¹, D. Nisbet¹, K. Nishida², M. O'Neil¹, M. Ohta², M. Paoluzzi¹, C. Pasquino¹, H. Pereira¹, J. Rochez¹, J. Sanchez Alvarez¹, J. Sanchez Arias¹, R. Scrivens¹, T. Shibata², D. Steyaert¹, N. Thaus¹, T. Yamamoto²,

¹CERN, 1211 Geneva 23, Switzerland

²Graduate School of Science and Technology, Keio University, 3-14-1 Hiyoshi, Kohoku-ku, Yokohama 223-8522 Japan,

(Presented XXXXX; received XXXXX; accepted XXXXX; published online XXXXX)

CERN's Linac4 45 keV H⁻ ion sources prototypes are installed at a dedicated ion source test stand and in the Linac4 tunnel. The operation of the pulsed hydrogen injection, RF sustained plasma and pulsed high voltages are described. The first experimental results of two prototypes relying on 2MHz RF- plasma heating are presented. The plasma is ignited via capacitive coupling, and sustained by inductive coupling. The light emitted from the plasma is collected by viewports pointing to the plasma chamber wall in the middle of the RF solenoid and to the plasma chamber axis. Preliminary measurements of optical emission spectroscopy and photometry of the plasma have been performed. The design of a cesiated ion source is presented. The volume source has produced a 45 keV H⁻ beam of 16-22 mA which has successfully been used for the commissioning of the Low Energy Beam Transport (LEBT), Radio Frequency Quadrupole (RFQ) accelerator and chopper of Linac4.

I. STATUS, CESIATED SURFACE ION SOURCE

The specification of the H⁻ source for the Linac4 is H⁻ ion pulses of 0.5 ms duration, 80 mA intensity and 45 keV energy within a normalized emittance of 0.25 π mm-mrad RMS at a repetition rate of up to 2 Hz. The Linac4 ion sources¹ stages towards this challenging goal consist in producing a H⁻ current of 20-30 mA in volume source derived from the concept developed at DESY² and a 40-50 mA ion current from a cesiated surface ion source inspired from the ion source of the Oak Ridge Spallation Neutron Source (SNS)³.

The 20 mA class volume source is operational in the Linac4 tunnel; it will be dedicated to the commissioning of the low energy sections of the Linac4. The first prototype of a cesiated Mo-surface RF H⁻ ion source is in the final stages of assembly. Both sources use the same beam extraction and electron dumping system which eases comparison between the two. The plasma generator is illustrated in figure 1; it consists of an alumina plasma chamber surrounded by a RF-solenoid plasma heating antenna and an 8-pole multi-cusp of permanent magnets in offset Hallbach configuration.

The plasma electrode is a bi-conical molybdenum element with a 6.5mm aperture; its inner surface faces the plasma and the atomic cesium dispenser, and its external surface the extraction field. We expect the low work function surface to generate H⁻ ions once submitted to the flux of H₀ atoms and H⁺ ions produced in the plasma. The cesiated surface can be heated via an internal resistance. The mechanical design enables operation with metallic sealing to minimize the presence of impurities; however, to keep maximum flexibility during preliminary tests the plasma chamber is now sealed with O-rings. The RF-solenoid antenna is molded within an epoxy cylinder around the ceramic chamber; flexible 3D printing of epoxy resin provided an efficient way to achieve regular spacing of the 3 to 6 turns silver coated copper tube solenoids. Their plasma heating properties will be individually tested. The back end of the plasma chamber is equipped with three view ports, a coaxial connection to the temperature controlled transfer line linking to the metallic cesium oven and a connection to the piezo valve driven pulsed hydrogen injection. The transfer line to the Cs-Oven is equipped with two metallic valves; once filled in a dedicated inert gas glove box, the cesium can be set and kept under vacuum, in view of the small amount of air trapped between the two all metal valves, the Cs-oven can be refilled without venting of the plasma chamber.

^{a)}Contributed paper published as part of the Proceedings of the 15th International Conference on Ion Source, Chiba, Japan, September, 2013.

^{b)}Jacques.lettry@cern.ch.

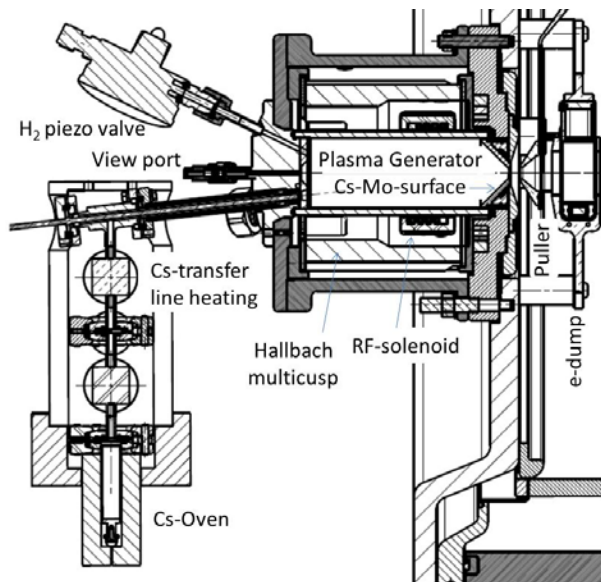

Figure 1: Scheme of the cesiated surface H⁻ ion source.

A. Simulation of the ion source

The plasma is inductively heated by up to 100 kW of 2 ± 0.1 MHz radio frequency (RF). Complex simulations are mandatory towards the engineering of plasmas dedicated to volume or cesiated surface H⁻ production. The electromagnetic RF-field distribution was simulated as a function of isotropic average plasma conductivity over several orders of magnitude⁴. RF to plasma coupling modes characterized by the penetrability of the electrical field into the plasma were identified. At ignition and low electron density, strong electrical fields are present throughout the volume of the plasma chamber while a skin effect is expected at very high electron density. An analytical transformer model was derived⁵ where the primary is the RF solenoid and the secondary is the azimuthal current flowing through the plasma and gave insight into the frequency tuning necessary to optimize the coupling of the RF to the plasma following the fast change in impedance induced at plasma ignition. A Particle In Cell (PIC) code developed by the KEIO University⁶ to calculate the dynamics of a RF heated plasma. With a purely inductive coupling, it was used to determine the minimal RF-power required to sustain and heat the plasma as a function of the H₂ pressure⁷ thus providing results similar to the experimental Paschen discharge characteristics. With the RF field⁴, initial electron- ions- and neutrals density distributions and the geometry of the cesiated surface prototype as input (but neglecting the permanent magnetic fields), the evolution of the plasma was studied for low electron density specific to plasma ignition and for densities up to 10^{18} m⁻³ typical for steady state operations⁸. The resulting time dependent electron densities and electron Energy Distribution Function (eEDF) were used as input into a collision radiation models to calculate the light emission from excited neutrals⁹ (see Fig. 2). As a preliminary result¹⁰, a very promising similarity between the simulation and the

Optical Emission Photometry (OEP) measurement of the H_α Balmer line during plasma ignition is observed.

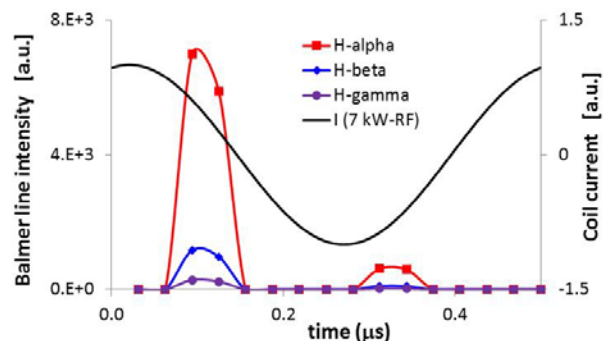

Figure 2: Simulated plasma light emission at plasma ignition, the phase of the RF-current passing through a 6 turns solenoid is indicated.

Within their domain of validity, these simulations effectively predict the RF-plasma coupling and provide a benchmark to observables in the visible light domain and provide an input to the simulation of the beam formation¹¹.

B. Operation and experimental results

Two ion sources were tested and operated, the first prototype of volume plasma generator directly inspired from the DESY geometry but with a different magnetic configuration and a 6-turn antenna upgraded for higher RF-power and directly molded on the alumina plasma chamber did produce a large current of co-extracted electrons but no useful H⁻ beam despite successfully holding up to 60 kW RF power with a RF-plasma coupling twice as high as the original DESY geometry. Solenoid antennas with 3 to 5 turns which should lead to lower RF-coupling have been produced and will soon be tested. After coupling to the new multistage extraction system, the copy of the DESY plasma generator produced at CERN was reliably functioning at low RF power (<20 kW) and at the nominal 45 keV beam energy. It was operated during 5 months for the ion source optics and LEPT measurement and for the commissioning of the 3MeV RFQ and chopper line. A post mortem however showed that air ionization had burned the insulation and some of the structural material.

The pulsed high voltage system and its active overcurrent protection functioned seamlessly, no trace of a spark found on the electrodes. The density regulation of the pulsed hydrogen injection demonstrated stability below 0.05%. The low level RF-control system is based on arbitrary functions of the RF-power and RF-frequency, this feature is essential to optimize the ignition and RF-coupling to the plasma. The stability of the ion current during the pulse is tuned by a ramp of the RF-power. A detailed analysis of the beam optics and magnetized einzel lens based low energy dumping of co-extracted electrons¹² predicted the typically 0.5-0.6 πmm-mrad H⁻ beam

emittance measured in the LEBT¹³. A detailed analysis of the beam parameters and high voltage currents shed light on the presence of secondary electrons that are captured by the electric fields¹⁴ and should be included in beam simulation. The hydrogen density regulation in the LEBT is operational and the effect of space charge compensation due to rest gas ionization was measured¹⁵. The beam current issued from the DESY plasma generator showed a very clear 2 MHz ripple ($\pm 10\%$) that is correlated to the reversal of the axial electrical field of the solenoid antenna.

C. Optical emission spectroscopy and test stands

The plasma light is collected through up to three viewports, either composed of O-ring sealed Quartz tubes or sealed with brazed sapphire windows, and focused via lenses on four quartz fibers per view port that transport the signals outside the high voltage protection cage. The setup allows simultaneous optical emission Spectroscopy (OES) and photometry (OEP) measurement. The OEP setup consists of Hamamatsu phototubes with a bandwidth of 10 MHz and the OES spectrometer is a double grating (2400 and 100 lines/mm) FHR1000 from Horiba equipped with an Intensified Charge Coupled Device (ICCD) camera and an optical port allowing the extraction of any wavelength of interest (i.e. into the OEP equipment). In the visible light spectrum, the Fulcher band characterizes excited hydrogen molecules and the Doppler broadening of the Balmer lines allows to determine the temperature of the hydrogen atoms.

The expected lowering of the work function of a Molybdenum surface relies on a thin layer of cesium, Inficon quartz micro-balance that can be moved along the vertical axis is installed in a test stand for Cs-evaporation that is equipped with flanges compatible to the Cs-oven of the ion source. The aim of this test stand is to coarsely measure the distribution of the cesium flow along the vertical axis and to calibrate the Cs-flux at the precise location of the cesiated Mo-surface for various transfer line and Cs-oven temperature settings. A vacuum chamber equipped with a fast vacuum gauge¹⁶ located within a mockup reproducing the inner geometry of the plasma chamber is assembled and ready to compare and measure the dynamic behavior of various types of valves.

II. CONCLUSION AND OUTLOOK

A new multi-electrode extraction system has been successfully implemented with a volume source, and a 45keV beam delivered to the RFQ for commissioning. The focus shall now be given to systematic testing of the cesiated prototype and improvement of the emittance. The plasma generators will be first tested on the Linac4 ion source with identical beam optics; however, the magnetized einzel lens that is designed to dump large amounts of co-extracted electrons also slows down the H⁺ ions. The extraction system will therefore be dedicated to

the measurement of electron to ion ratios that is an important input to the design of a new beam optics optimized for the cesiated plasma generator ion source and to reach the Linac4 emittance specification. Detailed simulation of the RF-solenoid heating, CR-modeling and OES measurements shed light on the capacitive plasma ignition process. Continued study of the plasma ignition and steady state properties, both through measurement and simulation, will improve the understanding of H⁺ ion generation.

¹J. Lettry, D. Aguglia, Y. Coutron, A. Dallochio, H. Perreira, E. Chaudet, J. Hansen, E. Mahner, S. Mathot, S. Mattei, O. Midttun, P. Moyret, D. Nisbet, M. O'Neil, M. Paoluzzi, C. Pasquino, J. Sanchez Arias, C. Schmitzer, R. Scrivens, D. Steyaert, J. Gil Flores, H- Ion Sources For CERN's Linac4, AIP Conf. Proc. 1515 (2013) pp.302-311.

²J. Peters, PAC05 Conference Proceedings, TPPE001, p. 788 (2005).

³M. Stockli, B. Han, T. Hardek, Y. Kang, S. Murray, T. Pennisi, C. Piller, M. Santana and R. Welton, Rev. Sci. Instrum. 83, 02A732 (2012)

⁴A. Grudiev, J. Lettry, S. Mattei, M. Paoluzzi, and R. Scrivens, *Numerical Simulation of Electromagnetic Fields and Impedance of CERN LINAC4 H Source taking into Account the Effect of the Plasma*, these proceedings.

⁵K. Nishida, S. Mochizuki, M. Yasumoto, M. Ohta, J. Lettry, S. Mattei, and A. Hatayama, *Equivalent Circuit of RF-Plasma with The Transformer Model*, these proceedings.

⁶S. Yoshinari, T. Hayami, R. Terasaki, A. Hatayama, and A. Fukano, Review of Scientific Instruments 81, 02A728 (2010)

⁷M. Ohta, S. Mattei, M. Yasumoto, A. Hatayama and J. Lettry, *Numerical Study of the Inductive RF-discharge Initiation for the Linac4 H- Ion Source*, these proceedings. *Hydrogen Atom Production Density Profile and H_α Intensity by CR Model*, these proceedings.

⁸S. Mattei, M. Ohta, M. Yasumoto, A. Hatayama, J. Lettry, A. Grudiev, *Plasma ignition and steady state simulations of the Linac4 H- Ion Source* these proceedings.

⁹T. Yamamoto, T. Shibata, M. Ohta, M. Yasumoto, K. Nishida, A. Hatayama, S. Mattei, J. Lettry, K. Sawada and U. Fantz, *Modeling of Neutrals in the Linac4 H- Ion Source Plasma*;

¹⁰T. Shibata, Private communication 2013.

¹¹M. Mochalski, J. Lettry, T. Minea, A. F. Lifschitz, C. Schmitzer, O. Midttun, D. Steyaert, Numerical modeling of the Linac4 negative ion source extraction region by 3D PIC-MCC code ONIX, AIP Conf. Proc. 1515 (2013) pp.31-40.

¹²Ø. Midttun, T. Kalvas, M. Kronberger, J. Lettry, R. Scrivens, A magnetized Einzel-lens electron dump for the Linac4 H- ion source, AIP Conf. Proc. 1515 (2013) pp.481-490.

¹³R. Scrivens, G. Bellodi, O. Crettiez, V. Atanasov Dimov, D. Gerard, E. Graneman Souza, R. Guida, J. Hansen, J.-B. Lallement, J. Lettry, A. Lombardi, Ø. Midttun, C. Pasquino, U. Raich, B. Riffaud, F. Roncarolo, C. A. Valerio-Lizarraga, J. Wallner, T. Zickler, *Linac4 Low Energy Beam Measurements with Negative Hydrogen Ions*, these proceedings.

¹⁴Ø. Midttun, J. Lettry, and R. Scrivens, *Measurements of Linac4 H Ion Source Beam with a Magnetized Einzel Lens Electron Dump*, these proceedings.

¹⁵C. A. Valerio-Lizarraga, J.-B. Lallement, I. Leon-Monzon, J. Lettry, Ø. Midttun, R. Scrivens, *Space Charge Compensation in the Linac4 Low Energy Beam Transport Line with Negative Hydrogen Ions*, these proceedings.

¹⁶E. Mahner, J. Lettry, S. Mattei, M. O'Neil, C. Pasquino, C. Schmitzer, Gas injection and fast-pressure-rise measurements for the Linac 4 H-source, AIP Conf. Proc. 1515 (2013) pp.425-432.