

Design study of an ERL Test Facility at CERN

E. Jensen, C. Bracco, O. Brüning, R. Calaga, N. Catalan-Lasheras, B. Goddard, M. Klein, R. Torres-Sanchez, A. Valloni, CERN, Geneva, Switzerland

Keywords : Energy Recovery Linac (ERL) Test Facility

Abstract

The modern concept of an Energy Recovery Linac allows providing large electron currents at large beam energy with low power consumption. This concept is used in FEL's, electron-ion colliders and electron coolers. CERN has started a Design Study of an ERL Test Facility with the purpose of 1) studying the ERL principle, its specific beam dynamics and operational issues, as relevant for LHeC, 2) providing a test bed for superconducting cavity modules, cryogenics and integration, 3) studying beam induced quenches in superconducting magnets and protection methods, 4) providing test beams for detector R&D and other applications. It will be complementary to existing or planned facilities and is fostering international collaboration. The operating frequency of 802 MHz was chosen for performance and for optimum synergy with SPS and LHC; the design of the cryomodule has started. The ERL Test Facility can be constructed in stages from initially 150 MeV to ultimately 1 GeV in 3 passes, with beam currents of up to 80 mA. Parameters to serve the above-mentioned purposes are well defined and lattice designs have well advanced.

Presented at :

5th International Particle Accelerator Conference, Dresden, Germany

Geneva, Switzerland

June, 2014

DESIGN STUDY OF AN ERL TEST FACILITY AT CERN[#]

E. Jensen^{*}, C. Bracco, O. Brüning, R. Calaga, N. Catalan-Lasheras, B. Goddard, M. Klein[†], R. Torres-Sanchez, A. Valloni, CERN, Geneva, Switzerland

Abstract

The modern concept of an Energy Recovery Linac allows providing large electron currents at large beam energy with low power consumption. This concept is used in FEL's, electron-ion colliders and electron coolers. CERN has started a Design Study of an ERL Test Facility with the purpose of 1) studying the ERL principle, its specific beam dynamics and operational issues, as relevant for LHeC, 2) providing a test bed for superconducting cavity modules, cryogenics and integration, 3) studying beam induced quenches in superconducting magnets and protection methods, 4) providing test beams for detector R&D and other applications. It will be complementary to existing or planned facilities and is fostering international collaboration. The operating frequency of 802 MHz was chosen for performance and for optimum synergy with SPS and LHC; the design of the cryomodule has started. The ERL Test Facility can be constructed in stages from initially 150 MeV to ultimately 1 GeV in 3 passes, with beam currents of up to 80 mA. Parameters to serve the above-mentioned purposes are well defined and lattice designs have well advanced.

INTRODUCTION

The Large Hadron electron Collider (LHeC, [1]) is a proposed electron-proton collider that uses one of the 7-TeV LHC proton beams, colliding it with a 60 GeV electron beam, generated in a proposed electron accelerator. The preferred concept for the latter is an energy recovery linac (ERL), since it would allow to keep the power consumption below 100 MW, even for beam parameters of 6.4 mA, 60 GeV, i.e. with a "virtual" beam power of 384 MW at the IP! These numbers illustrate the clear advantage of the modern concept of an ERL and give the motivation of this study; an ERL recovers the beam energy instead of wasting it on a dump.

CERN is starting design studies for accelerator projects to prepare for the post-LHC era, which include vigorous R&D on high-field magnets and high-gradient accelerating structures [2]. CERN's capabilities in superconducting RF (SRF) fell somewhat behind during LHC construction and significant effort is now being invested to make up this deficit; this includes upgrading our facilities for fabrication and testing of SRF cavities and cryomodules.

GOALS OF AN ERL TEST FACILITY

Study of a high-energy, multi-pass ERL

The main goal of the proposed ERL test facility is to study fundamental questions in the behaviour of an ERL itself: what fraction of beam energy can be extracted? How will the planned use of the high energy beam (FEL, collisions or other) affect the beam quality and thus limit this recovery process? If such limitation exists: what could be done to improve it? What are the beam dynamics where accelerated and decelerated beams share cavities and lattices? The basic parameters of the ERL were chosen such that it can give relevant answers to questions like these.

Test facility for SRF cavities and cryomodules

As mentioned in the introduction, CERN has started to strengthen its capabilities in SRF. These are needed to remain able to repair and upgrade LHC and HL-LHC cavities (401 MHz, 802 MHz), to design, construct, build and run cavities e.g. for HIE-ISOLDE. In the framework of the SPL study (704 MHz), 4-cavity cryomodules with 5-cell cavities have been designed and built (in close collaboration with ESS, Lund); SRF cavities have to be studied for future projects like the FCC (401 MHz, 802 MHz, [3]). For all of these projects and studies, the proposed ERL test facility would serve as training ground for technicians and engineers, with relevant parameters, including the possibility to study operational aspects with full power and beam interaction, but without perturbing the important physics exploitation of the LHC and its injector chain. To cite W. Funk from [4]: "*Be prepared to test, with full RF power systems and beam*".

Study injector and electron gun

An important part of the study is the injector and the electron gun, which should provide 330 pC bunches at a rate of 40 MHz. The preferred option would be a photo injector, but other options are currently also considered. A booster would accelerate the electron beam to at least 5 MeV (66 kW beam power) – ongoing simulations will indicate whether this energy has to be increased to better cope with space charge effects.

Possible use as beam facility

In addition to the use as a R&D facility for SRF and FELs themselves, the finished ERL could become a beam facility with interesting parameters for other applications, amongst them:

[#] This work is partially supported by the European Commission within the oPAC project under Grant Agreement 289485

^{*} mailto: Erk.Jensen@cern.ch

[†] University of Liverpool and CERN

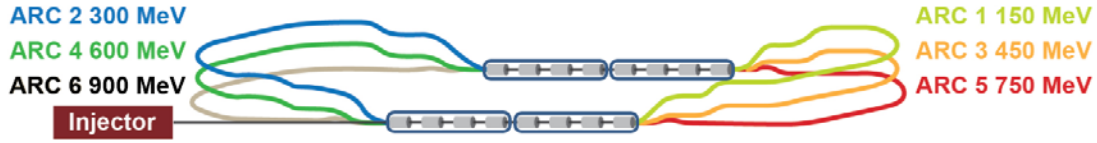

Figure 1: Conceptual layout of the ERL Test Facility

Controlled beam induced quenches: First FLUKA studies indicate that the beam parameters would allow relevant tests of quench thresholds in superconducting magnets for the next generation of accelerators. Stacks of superconducting cables, short sample magnets and even full-length LHC-type superconducting magnets could be tested extracting a small fraction of the electron beam at relevant energies.

In addition to superconducting cables and magnets, beam induced quenches in superconducting cavities could equally be studied.

Free Electron Laser: 10 mA of continuous electron beam at 900 MeV could be manipulated through an undulator or wiggler to produce nanometre or sub-nanometre radiation with narrow bandwidth.

PARAMETERS OF THE TEST FACILITY

Layout

In its full energy version, the ERL test facility will consist of two anti-parallel linacs with two 4-cavity cryomodules in each (cf. Fig.1). No focussing elements are foreseen in the linac. Vertical spreaders/combiners separate the beams into up to 3 vertically separated arcs, each of which is optimized for its nominal energy. The highest energy arc is adjusted in length to assure arrival in the decelerating phase when entering the linac again.

Table 1: Basic parameters of the test facility

Parameter	Value
injection energy	5 MeV
RF frequency	801.59 MHz
acc. voltage per cavity	18.7 MV
# cells per cavity	5
cavity length	≈ 1.2 m
# cavities per cryomodule	4
RF power per cryomodule	≤ 50 kW
# cryomodules	4
acceleration per pass	299.4 MeV
bunch repetition f	40.079 MHz
injected beam current	< 13 mA
nominal bunch charge	$320 \text{ pC} = 2 \cdot 10^9 e$
number of passes	2 3
top energy	604 MeV 903 MeV
duty factor	CW

RF System parameters

While a frequency of 721 MHz was used in [1], it was later found that a frequency of 802 MHz is possible for the LHeC (it has to be a harmonic of 40.1 MHz). Other

frequencies in discussion for the test facility were 704 MHz (SPL) or 1.3 GHz (X-FEL, ILC). A frequency of 802 MHz was eventually chosen since it is identical to the CERN SPS harmonic system, the LHC harmonic system presently under discussion and one of the frequencies envisaged for the FCC study.

Cavity and cryomodule concepts

The cavity design is based on existing SPL and JLAB experience; a first estimate of the cavity shape is sketched in Fig. 2. The cavities should be optimized for Q_0 while the accelerating gradient is kept at about 15 MV/m. HOM dampers will have to be designed for 3 accelerating and 3 decelerating passes, adding up to 80 mA and thus have to cope with substantial power.

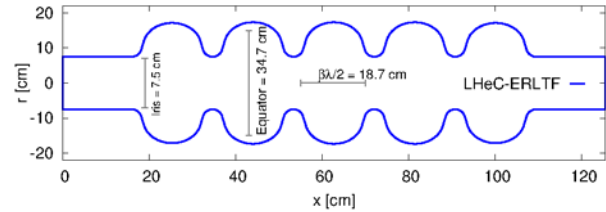

Figure 2: Approximate dimensions of a 5-cell cavity for 802 MHz

JLAB had designed an 805 MHz cryomodule for SNS, which is a good starting point for the 802 MHz design; the concept is indicated in Fig.3.

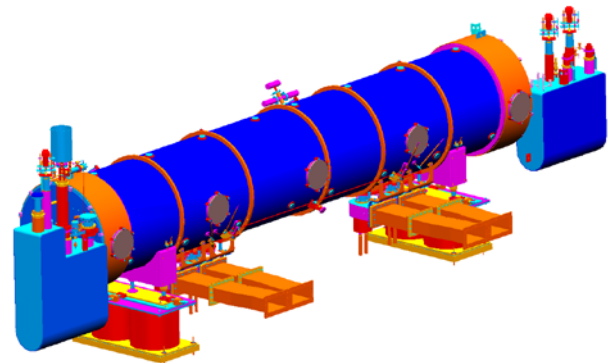

Figure 3: Conceptual design of the 802 MHz CM, SNS style [6]

Lattice

Appropriate recirculation optics are important to preserve beam quality. The design comprises 3 different regions, the linac, the arcs and the mergers. Due to the demand of providing a reasonable validation of the LHeC final system our design is, at present, involving a FMC cell based lattice featuring isochronicity, path length

controllability, large energy acceptance, small higher-order aberrations and tunability.

An example layout which fulfils these conditions is shown in Fig. 4, describing the lowest energy arc optics as example. It includes a two-step achromat spreader and a mirror symmetric combiner to direct the beam into the arc. The vertical dispersion introduced by the first step bend is suppressed by the quadrupoles located appropriately between the two stages. The switchyards separate all 3 arcs into a 90 cm high vertical stack, the highest energy arc is not elevated and remains at the linac-level. A horizontal dogleg, used for path length adjustment, is placed downstream of each spreader. The recirculating arc at 155 MeV is composed of four 90 cm long dipoles to bend the beam by 180° and of a series of quadrupoles (2 triplets and 1 singlet).

Diverse plausible optics layouts have been studied. A possible option would consist of arcs with identical configurations in order to have compact magnets stacked on top of each other. A complete first-order layout for switchyards, arcs and linac-to-arc matching sections has been accomplished for the arcs on both sides. The total beam path for a full 3 pass accelerating cycle is around 280 m. This leads to a total magnet count of approximately 200.

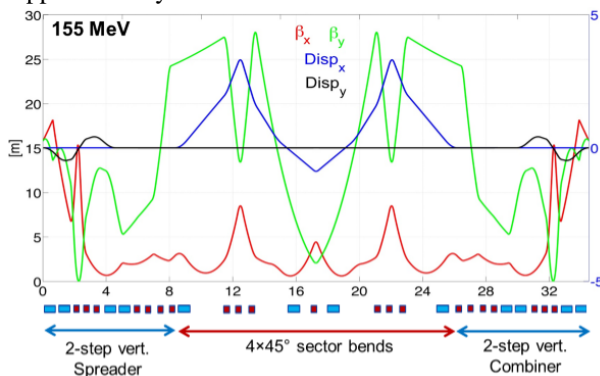

Figure 4: Optics based on an FMC cell of the lowest energy return arc at 155 MeV. Horizontal (red curve) and vertical (green curve) β -functions are shown. Blue and black curves show horizontal and vertical dispersion, respectively.

Site choices

Even while only in the conceptual design phase, we have started to look into possible existing buildings suited to host the ERL test facility. With an approximate footprint of $(45 \times 15)\text{m}^2$ of the ERL itself and the need for correctly dimensioned injector, dump and place for cryogenics, power supplies, RF amplifiers and instrumentation, not many existing halls are available on the CERN sites. A suitable hall of $(70 \times 16.5)\text{m}^2$ was identified near LHC P2, another one of even larger size on the Prévessin site.

PROPOSED STAGED DESIGN

The ERL test facility is designed to be constructed in stages. A first phase with recirculation would only use two 4-cavity cryomodules and single recirculation – it could reach 150 MeV. A second phase could feature multi-pass operation to reach 300 MeV (2 passes) or 450 MeV (3 passes). Adding two more cryomodules could boost the top energy to 900 MeV. More detailed description of the staged design can be found in [7].

INTERNATIONAL COLLABORATIONS

Strong synergy has been identified with the MESA project at Mainz University [8]; help with the design and construction of the 802 MHz cavities and cryomodules will result from collaboration with JLAB, who have already contributed significantly to the lattice and with their relevant experience operating CEBAF in ERL mode. CERN invites further collaborations, e.g. for the injector, magnets and other subsystems.

ACKNOWLEDGEMENTS

The authors wish to acknowledge the contributions to this work by many others, namely Kurt Aulenbacher (Mainz), Alex Bogacz and Andrew Hutton (JLAB) and Karl Schirm (CERN). We also acknowledge the support by present CERN directorate and former DG Herwig Schopper.

REFERENCES

- [1] LHeC Study Group: A Large Hadron Electron Collider at CERN, JPhysG **39**(2012) <http://iopscience.iop.org/0954-3899/39/7/075001>
- [2] The European Strategy for Particle Physics, Update 2013, <http://council.web.cern.ch/council/en/EuropeanStrategy/esc-e-106.pdf>
- [3] Future Circular Collider Study – Kickoff Meeting, Geveva, Switzerland 2014, <http://indico.cern.ch/event/fcc-kickoff>
- [4] W. Funk, “Jefferson Lab: Lessons Learned from SNS Production”, ILC Workshop 2004
- [5] A. Valloni et al., “Strawman Optics Design for the LHeC ERL Test Facility”, IPAC2013, Shanghai, <http://accelconf.web.cern.ch/AccelConf/IPAC2013/paper/tupme055>
- [6] A. Hutton, “JLAB ERL and a 802 MHz Cavity Design”, LHeC Workshop 2014, Chavannes-de-Bogis, <https://indico.cern.ch/event/278903/contribution/44>
- [7] A. Valloni, “TF - Stages and optics LHeC Workshop 2014, Chavannes-de-Bogis, Switzerland, <https://indico.cern.ch/event/278903/contribution/38>
- [8] K. Aulenbacher and F. Maas, “MESA – Mainz Energy-Recovering Superconducting Accelerator”, <http://www.prisma.uni-mainz.de/mesa.php>