

The High Voltage Protection Boards for the RICH Detectors of LHCb

C. Arnaboldi, T. Bellunato, P. Gobbo, D. L. Perego and G. Pessina

Abstract— We present the circuit protection system for the monitoring of the High Voltage bias for the Hybrid Photon Detectors (HPDs), of the Ring Imaging Cherenkov (RICH) detectors of LHCb. The protection system buffers the voltage lines, attenuated by about 12700 V/V, in normal operating conditions and limits the output voltage excursion to the ADC monitoring system to a safe range (between -2.5 V and +5 V) in case of discharge. The circuit is designed and tested to be radiation tolerant. The protection system has been fully characterized with radiation and temperature under the whole expected working conditions of LHCb. Results have shown that the developed protection boards are fully adequate for the whole LHCb lifetime.

I. INTRODUCTION

TWO Ring Imaging Cherenkov (RICH1 and RICH2) detectors [1], [2] will be used to identify charged particles, in the wide momentum range 1-100 GeV/c, at the LHCb experiment [3] under construction at the Large Hadron Collider machine, LHC. The photon detection is provided by a total of 484 Hybrid Photon Detectors, HPDs, developed by LHCb in close collaboration with industry [2]. RICH1 has 196 HPDs arranged in 14 columns with 14 photon detectors per column; RICH2 has 288 HPDs integrated in 18 columns with 16 HPDs per column. Three Cherenkov radiators are present, solid silica aerogel [5] and gaseous C_4F_{10} [3] in RICH1 and gaseous CF_4 in RICH2. Details on the two RICH detectors can be found elsewhere [2], [3].

The HPDs are biased with three High Voltages, HV: -20 KV, -19.7 KV and -16.4 KV. These three voltages are necessary to accelerate and to focalize the photoelectrons created by the Cherenkov photons striking on the multialkali layer deposited in the innermost part of the 7 mm thick entrance quartz window, having a diameter of 84 mm. A dedicated system based on Printed Circuit Boards, HV_PCB, one every 2 HPDs, developed to sustain the huge electric fields is directly integrated on each column, for the distribution of the HVs [6].

A very important feature is the monitoring of the HVs. Each half-column of the two RICH has a HV_PCB that houses three voltage attenuators that replicate the HVs at a level compatible with the reading system, the Embedded Local Monitor Board, ELMB [7]. Although the voltages at the attenuator output are expected to stay within an adequate

range, some precautions must be adopted to assure safe operation in case of accidental discharge from the HV lines. In this paper we will describe the system we have developed for this purpose. Experimental results are shown also for what concern the study of the radiation hardness to which the whole system must face during the LHCb lifetime.

II. THEORY OF OPERATION

The monitoring of the HV of the RICH detectors is possible from each half-column. Three voltage attenuators are present on one of the HV_PCB. The attenuators are shown in Fig. 1. The output in_{HV} is the HV scaled down by 12755 V/V factor. A capacitance and a Surge Arrester are put in parallel to the output resistor to limit the energy in case of accidental discharge. The limit is set to about $|100|$ V.

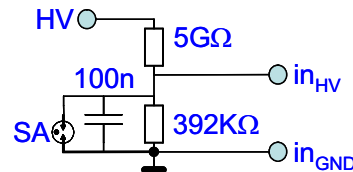

Fig. 1: Voltage attenuator present on the HV board. 3 such attenuators are present, one for every HV line. A Surge Arrester, SA, limit any discharge to be less than ± 100 V.

The ELMB is a multi-inputs instrument and it is foreseen to read out the HVs, at DC, from many attenuators like that of Fig. 1. The absolute maximum input range of the ELMB is from -2.5 V to +5 V. A further protection system, therefore, is necessary between the in_{HV} line of Fig. 1 and the ELMB input. Since the operating range of the ELMB is larger for positive signals and the HVs have negative polarity we have chosen to implement a differential input, differential output inverting unity gain buffer stage, able to guarantee the required safe operating range.

The circuit configuration of the buffer is shown in Fig. 2. The Operational Amplifiers, OA, used are the quad LMC6064 from National Semiconductor. They are CMOS OAs selected because at every input a pair of diodes connected to the supply rails is present. Diodes are put in such a way that their conduction state is set only if the corresponding input try to exceed any rail. This feature is guaranteed if the current flowing to the input is maintained below 10 mA. To satisfy this constraint we put resistors R_1 and R_2 in series to U_1 input and R_3 , R_4 to U_2 input. In this way the corresponding input signal may swing up to 660 V, while the OA outputs saturate towards the rail. Actually, safe operation of the 1 W selected resistors is 150 V, well above that expected at the Surge

Manuscript received November 26 2007.

C. Arnaboldi, T. Bellunato, P. Gobbo, D. L. Perego and G. Pessina, are with INFN, Sezione di Milano-Bicocca and Dipartimento di Fisica dell'Università di Milano-Bicocca, P.za della Scienza 3, Milano I-20126, Italy, Gianluigi.Pessina@mib.infn.it

Arrester terminals of Fig. 1 in case of discharge. To further limit the slew rate, capacitances C_1 and C_2 are added in the circuit of Fig. 2.

The buffer of Fig. 2 is connected to the homonymous terminals of Fig. 1. Since the Protection Board, PRB, that will house the buffers will be located about 20 m from the detector, the differential input configuration allows to reject common mode noise.

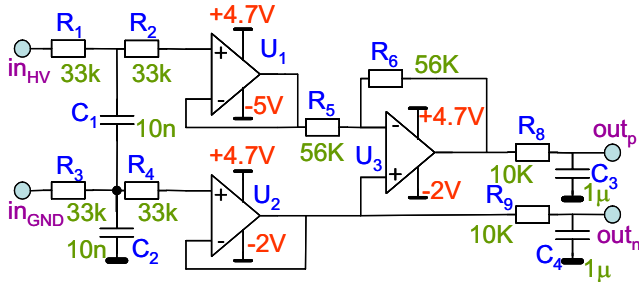

Fig. 2: Schematic diagram of the buffering of the attenuated HV of Fig. 1.

In normal operating condition the input current of U_1 and U_2 is very small. As a consequence the voltage drops across R_1 to R_4 are negligible and no DC offset is added to in_{HV} and in_{GND} : the input stage operates as a standard unity gain buffer stage. U_3 invert the signal of U_1 and U_2 to generate a positive differential voltage at the out_p and out_n terminals in response to a negative input swing. As stated above, when a large voltage is applied to the inputs U_1 and U_2 saturate their output stages towards the rail. As a consequence saturation of the output occurs also at the output of U_3 . To comply with the safe operation of the ELMB we simply operate the 3 OAs with supply voltage rails having adequate levels. As it can be seen in Fig. 2 the outputs of U_2 and U_3 can saturate to values larger than -2 V and smaller than $+4.7$ V. In this way the out_p and out_n can be connected to the differential inputs of the ELMB with safe margin even if the input swings to more than $|100|$ V. At the output of Fig. 2 a pair of low pass filters is present to lower the noise at the differential inputs of the ELMB.

The supply voltages necessary to the PRB are generated on the board itself. Fig. 3 shows the circuit solution. Only one positive input voltage is necessary in the limit between $+6$ V and $+15$ V. The linear regulator LP2981 generates a 5 V output to which Zener Z_1 , 5.6 V, is connected for over voltages protection. Zener Z_2 is connected to the 5 V line through a 56 Ω resistor to generate the 4.7 V positive rail.

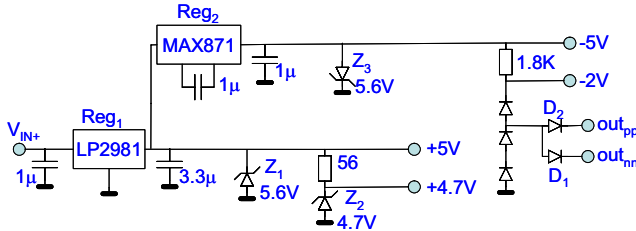

Fig. 3: Regulation system present on the PRB.

The inverter, charge-pump type, MAX871 generates the -5 V starting from the regulated $+5$ V. Also in this case Z_3 ,

5.6 V, protects it from over-voltages. The -2 V negative rail is generated by the series combination of 3 diodes and a 1.8 K Ω resistor. Two additional outputs are present connected to diodes D_1 and D_2 , out_{pp} and out_{nn} . These 2 lines limit the corresponding excursion to be above about -2 V. This arrangement is exploited from the buffer circuit of Fig. 4. The Silicon chip present at the base of each HPD need a positive bias voltage of $+100$ V, which needs to be monitored, too. An inverting buffer stage is not needed for this monitoring. Nevertheless the negative and positive swings must also comply with the ELMB. OAs U_4 and U_5 of Fig. 4 are part of a LMC6064, that is a quad OA. They are in the same package with other 2 OAs that have the rails at -5 V and $+4.7$ V. To obtain the compliant value of -2 V out_{pp} and out_{nn} are connected to the homonymous lines of the supply voltage of Fig. 3.

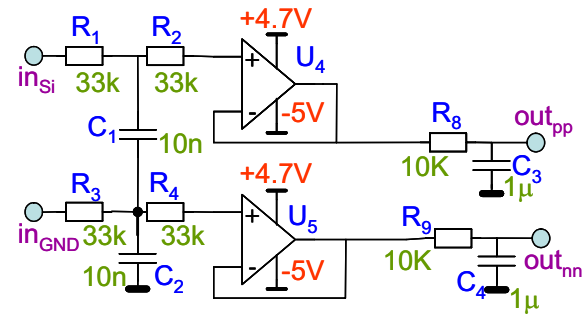

Fig. 4: Schematic diagram of the buffering of the Silicon bias voltage.

Each PRB is configured with the 6 inverting buffers, Fig. 2, one buffer, Fig. 4 and the bias supply generators of Fig. 3. In this way one complete column can be monitored by one PRB. The layout of the PRB occupies an area of 100×220 mm², on two layers. In total 32 PRBs are necessary to equip RICH1 and RICH2. In Fig. 5 the Top and Bottom layers of the PRB are shown. In the upper part of the Bottom layer 2 lines consisting of the 1 W resistors (R_1 to R_4 of Fig. 2) for the 7 channels are visible. They are integrated on the board with large clearance to avoid possible side discharge effects. Voltage regulators are in the lower part of the Bottom layer. All the OAs and the filtering capacitances (all polyester types) are integrated on the Top layer. Final versions of the PRB prototype have been already tested with satisfactory results [8], [9]. The production of the PRB is being equipping the 2 RICH.

III. TEST SET-UP

LHCb is an experiment expected to take data for 10 years without, or with a very minimal, human intervention in the experimental area. The equipment to be used must guarantee a high level of reliability and, very important, to be radiation tolerant. We have considered a crucial step in the development of the PRBs their validation under all the possible working conditions. Since the many parameters that characterize any PRB, an automatic system controlled by a Personal Computer, PC, has been developed to manage data and measuring.

An interface card provides the input signals to the boards, in order to simulate the full experimental condition. In Fig. 6 we show the interface card configuration. A set of bi-stabile, double switch, relays, SW_1 to SW_5 , are programmed by means of a Digital I/O card, PCI-6503 from National Instruments, embedded in the PC.

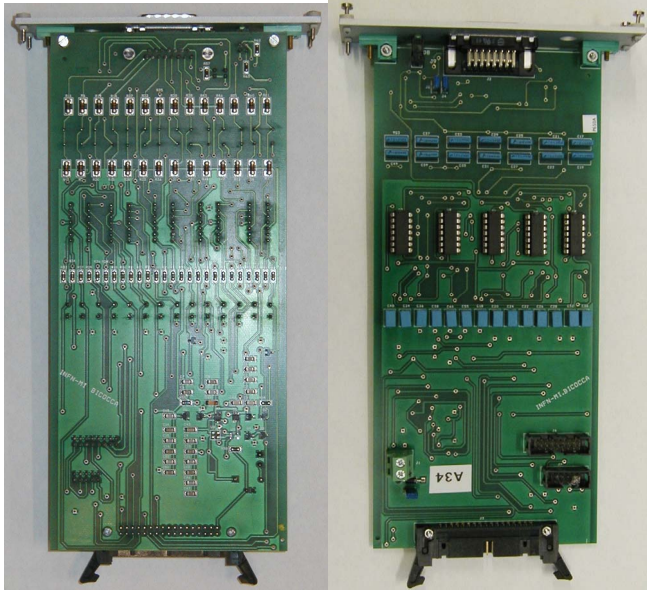

Fig. 5: Picture of the PRB, bottom view on the left and top view on the right.

SW_5 has its two outputs connected to one PRB. One of its outputs feeds the odd channels, the other feeds the even channels and the seventh channel dedicated to the buffering of the monitoring of the Silicon bias. With SW_5 it is possible to swap the two outputs of SW_3 . This last relay allows for two options. In the first one both of its outputs are shorted together, feeding in this way the same low voltage signal to all the 7 channels. Four levels are possible, combining the setting

of SW_1 and SW_2 : Ground, -0.65 V, -1.27 V and -1.87 V. The Ground connection was chosen for studying the offset versus the temperature. The other 3 signal voltages allow characterizing linearity and gain. The second option offered by SW_3 consists in the application of the, sudden, -150 V discharge on one output and -1.87 V at the other output. In this way 3 channels of the PRB are subjected to a simulated discharge, while the others are in normal operating condition. This is the worst case condition.

SW_4 has its outputs connected to two inputs of the reading multimeter allowing safe operation. Before any discharge the multimeter inputs are shorted to ground by SW_4 , then, after the transient is ended, the reading lines are re-connected.

The inspection of the discharge applied to the PRB can be done with an oscilloscope connected to the discharge line at the SW_3 output via the voltage attenuator given by R_7 to R_{10} .

The PC, via MATLAB^{®1}, controls the SWs of Fig. 6, the multimeter and the scope. The multimeter is a Keithley-2700 that was configured with 40 multiplexed inputs with which we were able to read all the signals of interest and also the supply voltage levels. In addition, the PC was also able to control the environmental chamber, Vötsch VC 4070, to study the temperature behaviour.

An example of output of a single channel from a PRB in response to the signal pattern that can be generated from the set-up of Fig. 6 is shown in Fig. 7. During the measurement shown in Fig. 7 the temperature was varied from -10°C to 60°C with a slope of about $0.1^{\circ}\text{C}/\text{min}$, in order to maintain the PRB in thermal equilibrium.

The input signals to the PRB are recorded (see SW_4 in Fig. 6). By correlating the input pattern and the data from the PRB outputs it was possible to extract the complete diagnostic for all the channels.

Results obtained on the full production of 34 boards were

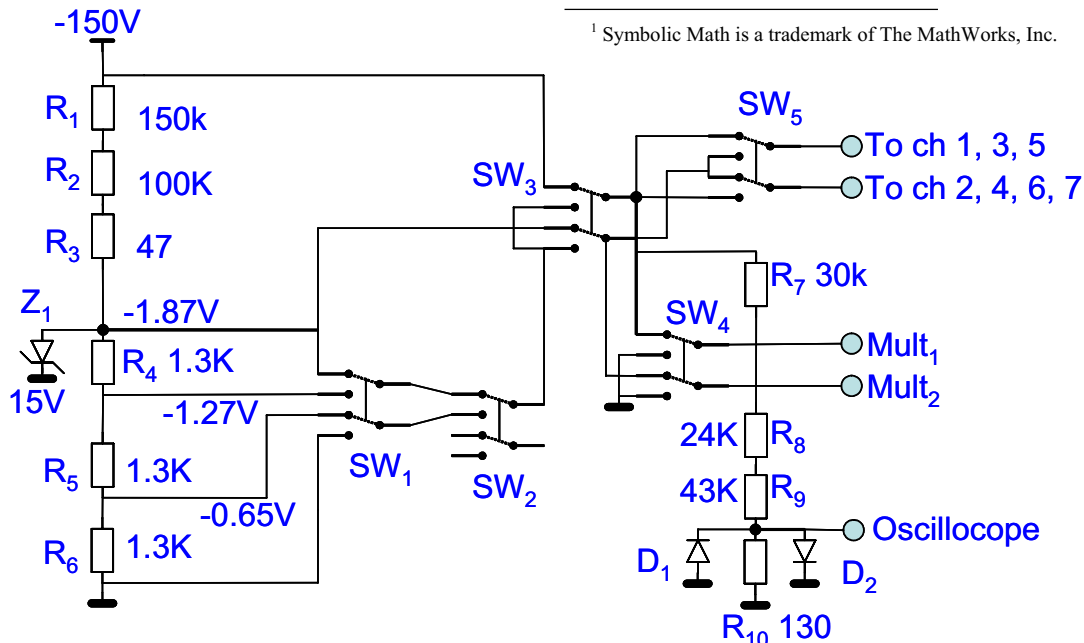

Fig. 6: Set-up for the test of the PRB against discharges, linearity and offset.

¹ Symbolic Math is a trademark of The MathWorks, Inc.

very good. The offset resulted 0.040 ± 0.730 mV on the average, with a drift of only 0.264 ± 4.640 $\mu\text{V}/^\circ\text{C}$. Linearity was excellent thanks to the small closed loop gain of the buffer. The drift of the gain resulted -0.368 ± 6.280 ppm/ $^\circ\text{C}$.

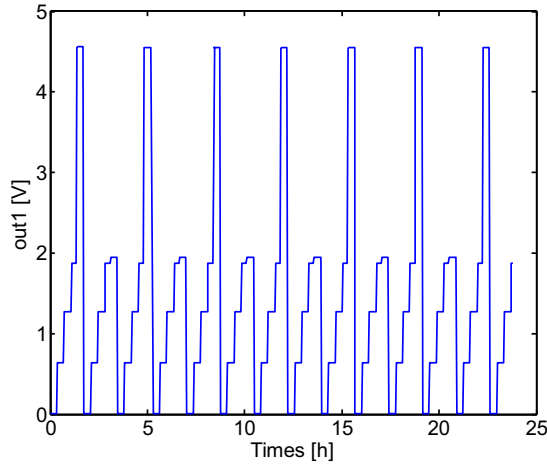

Fig. 7: Output from one channel of the PRB in response to the input pattern generated with the set-up of Fig. 6.

Three boards have been tested at the TRIGA MARK II reactor in Pavia (Italy) against radiation. During 6 hours of irradiation the boards have been exposed to an integrated fluence of 4×10^{13} 1 MeV equivalent neutrons/cm² and 43 kRad dose from γ -rays. This corresponds to about 40 times the lifetime of LHCb in the location of the PRBs, the bunker. No appreciable effect has been observed on the behavior of the OAs. The bias supply voltages changed only by 7 % after the whole irradiation period. The radiation effect on the supply voltages is negligible for doses corresponding to the lifetime of LHCb.

ACKNOWLEDGMENT

We thank Antonio De Lucia and Giulio Galotta for the accurate layout preparation of the circuits and measurement set-up.

REFERENCES

- [1] T.Ypsilantis, J.Seguinet, Theory of ring imaging Cherenkov counters, Nucl. Inst. and Meth. in Phys. Res., Vol. A343, 30-51, 1994.
- [2] The LHCb Coll., LHCb RICH Technical Design Report TDR3, CERN/LHCC/2000-037 (2000).
- [3] The LHCb Coll., LHCb Reoptimized Detector Design and Performance TDR, CERN/LHCC/2003-030 (2003).
- [4] M. Moritz, G. Aglieri Rinella, L. Allebone, M. Campbell, T. Gys, C. Newby, A. Pickford, D. Piedigrossi, and K. Wyllie, Performance study of new pixel hybrid photon detector prototypes for the LHCb RICH counters, IEEE Trans. Nucl. Sc., Vol. 51, 1060-1066, 2004.
- [5] T.Bellunato, M.Calvi, C.Matteuzzi, M.Musy, D.L.Perego, B.Storaci, Refractive index dispersion law of silica aerogel, Eur. Phys. J. C 52, 759-764, 2007.
- [6] C.Arnaboldi, T.Bellunato, T.Gys, E.Panzeri, G.Pessina, and D.Piedigrossi, The high voltage distribution system for the hybrid photodetector arrays of RICH1 and RICH2 at LHCb, IEEE Trans. Nucl. Sc., Vol. 53, 1397-1402, 2006.
- [7] The ELMB homepage, <http://elmb.web.cern.ch/ELMB/ELMBhome.html>.
- [8] M.Adinolfi, G.Aglieri Rinella, E.Albrecht, M.Ameri, C.Arnaboldi, T.Bellunato, J.Bibby, T.Blake, S.Cuneo, J.Dickens, S.Easo, U.Egede, F.Fontanelli, V.Gibson, T.Gys, R.Hallam, N.Harnew, A.Howard, N.Kanaya, S.Katvars, C.Matteuzzi, J.McCarron, G.Mini, F.Muheim, E.Panzeri, M.Patel, G.Pessina, D.Piedigrossi, R.Plackett, M.Sannino, J.Storey, P.Sullivan, S.Topp-Jorgensen, A.Van Lysebetten, G.Vidal-Sitjes, D.Websdale, S.Wotton, K.Wyllie, Performance of the LHCb RICH photodetectors in a charged particle beam, Nucl. Inst. and Meth. in Phys. Res., Vol. A574, 39-49, 2007.
- [9] Davide L. Perego, on behalf of the LHCb RICH Collaboration, The performance of the LHCb Pixel Hybrid Photon Detectors in a 25ns structured test-beam, submitted to IEEE Trans. Nucl. Sc. on November 2007.