

Upgrade of the ATLAS Muon Trigger for the SLHC

This article has been downloaded from IOPscience. Please scroll down to see the full text article.

2010 JINST 5 C12016

(<http://iopscience.iop.org/1748-0221/5/12/C12016>)

View [the table of contents for this issue](#), or go to the [journal homepage](#) for more

Download details:

IP Address: 137.138.124.142

The article was downloaded on 11/07/2011 at 13:51

Please note that [terms and conditions apply](#).

TOPICAL WORKSHOP ON ELECTRONICS FOR PARTICLE PHYSICS 2010,
20–24 SEPTEMBER 2010,
AACHEN, GERMANY

Upgrade of the ATLAS Muon Trigger for the SLHC

J. Dubbert, S. Horvat, O. Kortner, H. Kroha and R. Richter¹

*Max-Planck-Institute for Physics,
Munich, Germany*

E-mail: richterr@mpp.mpg.de

ABSTRACT: The outer shell of the ATLAS experiment at the LHC consists of a system of toroidal air-core magnets in order to allow for the precise measurement of the transverse momentum (p_T) of muons, which in many physics channels are a signature of interesting physics processes [1, 2]. For the precise determination of the muon momentum Monitored Drift Tube chambers (MDT) with high position accuracy are used, while for the fast identification of muon tracks chambers with high time resolution are used, able to select muons above a predefined p_T threshold for use in the first Level of the ATLAS triggering system (Level-1 trigger). When the LHC peak luminosity of $10^{34} \text{ cm}^{-2} \text{ s}^{-1}$ will be increased by a factor of 4–5 in about a decade from now ("SLHC"), an improvement of the selectivity of the ATLAS Level-1 triggering system will be mandatory in order to cope with the maximum allowed trigger rate of 100 kHz. For the Level-1 trigger of the ATLAS muon spectrometer this means an increase of the p_T threshold for single muons. Due to the limited spatial resolution of the trigger chambers, however, the selectivity for tracks above $\sim 20 \text{ GeV}/c$ is insufficient for an effective reduction of the Level-1 rate. We describe how the track coordinates measured in the MDT precision chambers can be used to decisively improve the selectivity for high momentum tracks. The resulting increase in latency will also be discussed.

KEYWORDS: Muon spectrometers; Particle tracking detectors; Large detector systems for particle and astroparticle physics; Particle tracking detectors (Gaseous detectors)

¹Corresponding author.

Contents

1	Introduction	1
2	Performance limits of RPC trigger chambers	1
3	Inclusion of the MDT precision chambers into the L1 decision	4
3.1	Towerwise structure of the Level-1 trigger	4
3.2	Interface between MDT and RPC	5
3.3	Synchronization of the readout with the TTC clock	5
3.4	Reduction of the drift time resolution	6
4	Summary	6

1 Introduction

While peak luminosities at the SLHC will be 4–5 times higher compared to the LHC design luminosity of $10^{34} \text{ cm}^{-2} \text{ s}^{-1}$, the Level-1 trigger rate will have to remain at about 100 kHz. For this to happen the trigger selectivity for muons with high transverse momentum (p_T) has to be improved, the p_T distribution of muons falling off strongly with increasing p_T (figure 1). Total muon cross sections above p_T values like 10, 20 and 40 GeV are 734, 47 and 3 nb, respectively.

Many interesting physics processes with small cross sections have a signature of one (or more) muons above ~ 20 GeV. The capability to trigger on high- p_T tracks was therefore one of the principal requirements for the design of the ATLAS muon spectrometer [1, 2]. For this purpose a system of trigger chambers was implemented, covering the full acceptance of the muon detector, capable to detect tracks above a predefined p_T within a sufficiently short latency to be used in the ATLAS Level-1 trigger. In the barrel and end-cap regions different chamber technologies were chosen, adapted to the different configurations of the magnetic field in these detector domains. In this article we describe the barrel region, where the Resistive Plate Chamber (RPC) technology is used.

2 Performance limits of RPC trigger chambers

RPCs use pick-up strips perpendicular to the z -direction (cf. figure 4) to sense the avalanches generated by traversing particles in the chamber gas, measuring the coordinates of the tracks along the bending direction of the magnetic field. The time resolution of about 20 ns of the RPC chambers is sufficient to tag the beam crossing with about 95 % confidence. Figure 2 shows the schematics of the Level-1 triggering system in the barrel region. RPC trigger chambers (marked in green) are positioned at three radial positions of the barrel, one in the outer detector layer (BO) and two in the middle layer (BM), below and above the middle MDT.

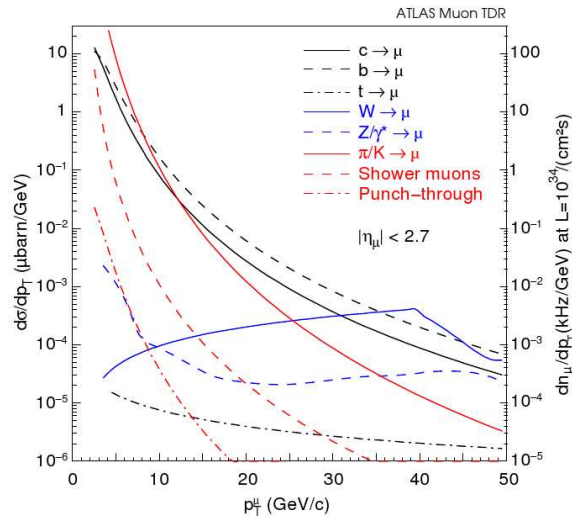

Figure 1. Transverse momentum distribution of muons in the ATLAS muon spectrometer for various production channels.

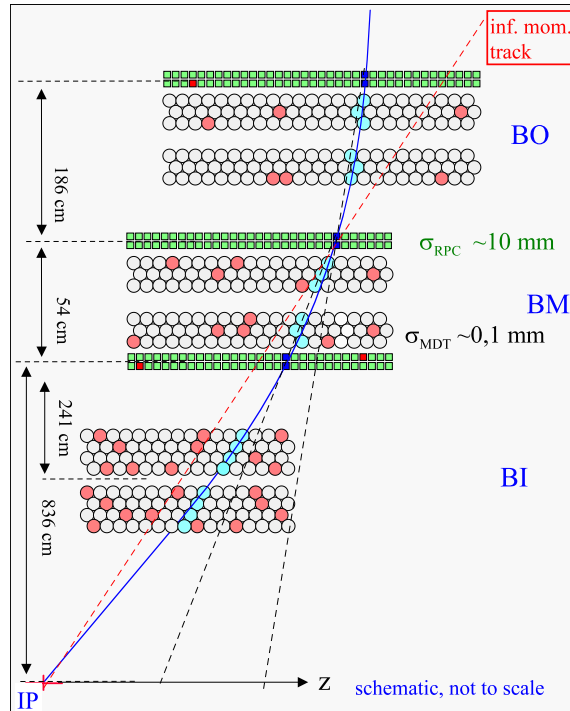

Figure 2. Implementation of the Level-1 trigger in the muon barrel region. The field lines of the B-field are perpendicular to the drawing plane.

The slopes in the bending direction (η) of the track between inner and middle as well as between middle and outer RPC layer are compared to the slope of a track with infinite p_T , i.e. a straight line coming from the interaction point (IP), the difference of the slopes being a measure of p_T , where large deviations mean low p_T , while tracks with small deviation from a straight

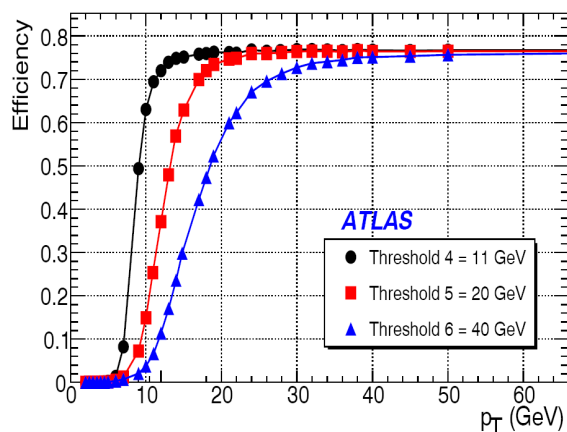

Figure 3. Acceptance of the Level-1 trigger vs. p_T for three typical trigger thresholds. For the 20 and 40 GeV thresholds the transitions from 90–10% efficiency cover a wide p_T -range, leading to high rates of unwanted triggers.

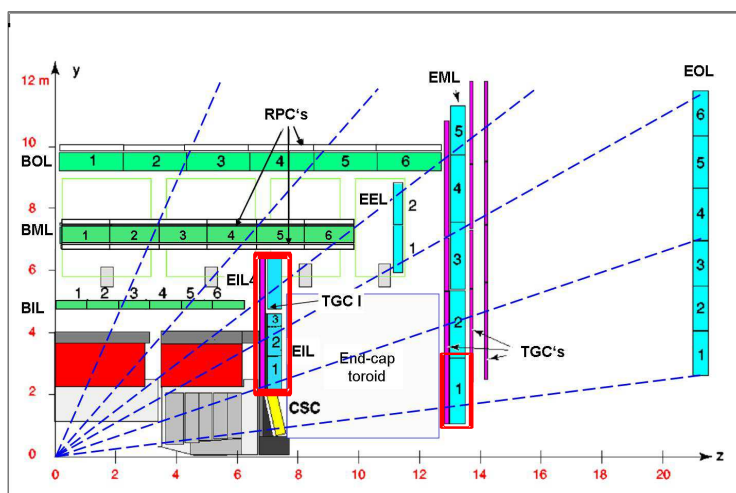

Figure 4. Tower structure of the muon spectrometer. In the barrel there are 12 towers along the η and 16 along the ϕ -direction (see text). Each tower only contributes a small rate of high- p_T Level-1 triggers (< 100 Hz), reducing bandwidth requirements for the readout.

line mean high p_T . For the fast comparison of the slope of a track with the one of a infinite momentum track a system of coincidences between the pick-up strips of the three RPC layers is used ('coincidence matrices').

The width of the RPC strips of about 30 mm limits the precision of the slope measurement of the track. At a p_T of 10, 20 and 40 GeV sagittas are 48, 24 and 12 mm, respectively, leading to a corresponding uncertainty of the threshold, as shown in figure 3. With a threshold setting of 20 GeV (square dots) the trigger is still accepting about 60% of the 15 GeV and 15% of the 10 GeV tracks and is thus not efficiently selecting the interesting physics events. Replacing the present RPC chambers by ones with higher spatial resolution would be an obvious solution. This costly conversion could be avoided, however, if the high spatial resolution of the nearby MDT chambers

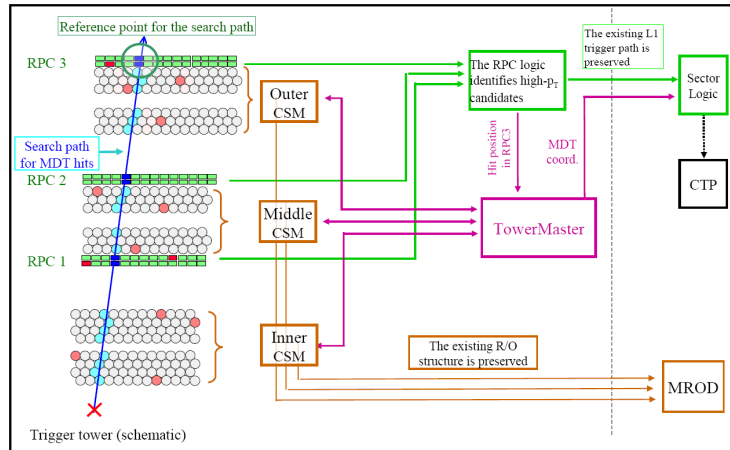

Figure 5. Readout architecture to combine the precision track coordinates determined in the MDT chambers with the trigger information supplied by the RPC's. Only MDT hits along the search path are read out, those outside (mainly background hits from γ conversions) are ignored, reducing the required bandwidth.

could be used for the Level-1 trigger. For this to happen, the transfer of information from the MDT to the Level-1 triggering system must be sufficiently fast to remain inside the overall ATLAS trigger latency.

The challenge for an improvement of the Level-1 trigger is to design a MDT readout scheme and an interface to the RPC trigger, able to deliver a refined p_T -value inside the latency limits of the ATLAS trigger. The present latency budget of $2,5 \mu\text{s}$, adapted to the situation at the original LHC, is insufficient for any refinement of the trigger decision. For SLHC, however, an increase of the latency to $6,4 \mu\text{s}$ or even $10 \mu\text{s}$ will be implemented for the frontend data storage of all subdetectors, providing considerable design freedom for Level-1 trigger improvements.

3 Inclusion of the MDT precision chambers into the L1 decision

3.1 Towerwise structure of the Level-1 trigger

The muon spectrometer is partitioned in projective towers along the direction of pseudo rapidity η and the azimuthal direction ϕ , where trigger and precision chambers are matched in size and location in each tower, see figure 4. High- p_T tracks, following nearly straight lines, will mostly travel inside one projective tower, and therefore each tower can evaluate its high- p_T triggers independently from neighbouring towers. The straight high- p_T tracks define narrow search paths, where MDT hits, belonging to the triggering track must be located. The readout of the MDT chamber can therefore be limited to a small number of tubes along the track trajectory (see left part of figure 5). The search path is communicated from the RPC to the MDT via the coordinate of the track in the outer RPC.

The present readout architecture of the MDT chambers is described in [3]. Being sequential and asynchronous with the TTC, it is not suited for the Level-1 refinement. An additional, fast readout path of the MDT is therefore required, in parallel and independent of the existing one (see

This quality check of the drift time reading becomes particularly important at high background rates, where conversion events may occur at a high rate and may frequently degrade the drift time reading from a traversing muon.

3.4 Reduction of the drift time resolution

The resolution of the MDT drift time will be reduced from 12 to 6 bit, the corresponding position resolution of the MDT of about 1 mm (RMS) being still about a factor 10 better than the one of the RPC, sufficient for a decisive sharpening of the Level-1 trigger threshold. Corrections for the non-linear r-t relation in the MDT gas and other small effects can be neglected at this level of precision. With the reduction of the number of bits, data volumina and transmission delays are reduced. In addition, data redundancy and format overheads will be reduced to the strict minimum.

An analysis of the time behaviour of such a readout model shows that a latency of 4,5–5,5 μs could be achieved and thus would be a realistic option for the upgrade of the muon Level-1 trigger for the SLHC. A significant advantage of this scheme would be that the existing RPC trigger chambers, except electronics, would not need any modifications.

A similar upgrade scheme could also be applied to the Level-1 trigger in the end-cap region where trigger chambers of the TGC type are used [1, 2]. Because of the different geometry of the toroidal magnetic field and the different location of trigger and MDT chambers, however, a modified architecture and specialized algorithms will have to be used.

4 Summary

The upgrade scheme for the Level-1 muon trigger described above allows to sharpen the threshold of the high- p_T trigger by about an order of magnitude, sufficient for the luminosity increase envisioned for the SLHC. This way the existing RPC trigger chambers can stay in place. The readout electronics of RPC as well as MDT will need complete replacement. A number of readout units along the data path will have to be designed to contain local intelligence and the possibility for precise timing adjustment in order to fulfill the synchronicity requirement, mentioned above. Design, prototyping, production and installation will require a significant effort and a strong contribution from the ATLAS muon spectrometer community.

References

- [1] ATLAS collaboration, *ATLAS muon spectrometer: technical design report*, [CERN-LHCC-97-022](#) (1997).
- [2] ATLAS collaboration, *The ATLAS experiment at the CERN Large Hadron Collider*, [2008 JINST 3 S08003](#).
- [3] Y. Arai et al., *ATLAS muon drift tube electronics*, [2008 JINST 3 P09001](#).