

EUROPEAN ORGANIZATION FOR NUCLEAR RESEARCH
CERN - ACCELERATORS AND TECHNOLOGY SECTOR

CERN-ATS-2010-019

COOLING SYSTEM FOR THE MERIT HIGH-POWER TARGET EXPERIMENT

F. Haug¹, H. Pereira¹, P. Silva¹, M. Pezzetti¹, O.Pavlov¹, O. Pirotte¹, J. Metselaar¹, I. Efthymiopoulos¹, A. Fabich¹,
J. Lettry¹, H.G. Kirk², K.T. McDonald³, P. Titus⁴, and J.R.J Bennett⁵

Abstract

MERIT is a proof-of-principle experiment of a target station suitable as source for future muon colliders or neutrino factories. When installed at the CERN (European Organization for Nuclear Research) PS (Proton Synchrotron) complex fast-extracted high-intensity proton beams intercepted a free mercury jet inside a normal-conducting, pulsed 15-T capture solenoid magnet cooled with liquid nitrogen. Up to 25 MJ of Joule heat was dissipated in the magnet during a pulse. The fully automated, remotely controlled cryogenic system of novel design permitted the transfer of nitrogen by the sole means of differential pressures inside the vessels. This fast cycling system permitted several hundred tests in less than three weeks during the 2007 data taking campaign.

- 1 CERN, European Organization for Nuclear Research, Geneva, Switzerland
2 BNL, Upton, NY, USA
3 Princeton University, Princeton, NJ, USA
4 NW22-225 MIT Plasma Science and Fusion Center, Cambridge, MA, USA
5 CCLRC, RAL, Chilton, UK

Presented at the Cryogenic Engineering Conference and International Cryogenic Materials Conference
(CEC/ICMC 2009) - 28 June-2 July 2009, Tucson, USA

Geneva, Switzerland

January 2010

COOLING SYSTEM FOR THE MERIT HIGH-POWER TARGET EXPERIMENT

F. Haug¹, H. Pereira¹, P. Silva¹, M. Pezzetti¹, O.Pavlov¹, O. Pirotte¹, J. Metselaar¹, I. Efthymiopoulos¹, A. Fabich¹, J. Lettry¹, H.G. Kirk², K.T. McDonald³, P. Titus⁴, and J.R.J Bennett⁵

¹CERN
CH-1211, Geneva, 23, Switzerland

²BNL
Upton, NY 11973, USA

³Princeton University
Princeton, NJ 08544, USA

⁴NW22-225 MIT Plasma Science and Fusion Center
185 Albany Street, Cambridge MA 02139, USA

⁵CCLRC, RAL
Chilton, OX11 0QX, UK

ABSTRACT

MERIT is a proof-of-principle experiment of a target station suitable as source for future muon colliders or neutrino factories. When installed at the CERN (European Organization for Nuclear Research) PS (Proton Synchrotron) complex fast-extracted high-intensity proton beams intercepted a free mercury jet inside a normal-conducting, pulsed 15-T capture solenoid magnet cooled with liquid nitrogen. Up to 25 MJ of Joule heat was dissipated in the magnet during a pulse. The fully automated, remotely controlled cryogenic system of novel design permitted the transfer of nitrogen by the sole means of differential pressures inside the vessels. This fast cycling system permitted several hundred tests in less than three weeks during the 2007 data taking campaign.

KEYWORDS: pulsed magnet, fast cycling cooling system, target experiment, muon collider.

INTRODUCTION

High energy particle accelerators, colliders and detectors allow the understanding of the basic structure of matter. Advances in high energy physics depends on the advances of the technologies in this domain. The range of particle beams available nowadays is limited to the interaction of stable charged particles: electrons, protons, their anti-particles and, heavy ions. With the LHC (Large Hadron Collider) collider being in the start-up phase at CERN, important discoveries will be possible over the next decade using stable particles

like protons and heavy ions at the high energy frontier. Beyond LHC new types of colliders are studied. Among them are the proposed muon colliders and neutrino factories. Muons accelerated to high energies would enlarge the particle physics horizon. They have the advantage of being 200 times heavier than electrons, however, are unstable and decaying with a $2.2 \mu\text{s}$ lifetime at rest. A rapid acceleration to relativistic velocities after their production is needed to increase their lifetime. Advanced technologies are required for such machines. One of them is the target to produce high intensity muon beams for which the MERIT experiment has been designed. Muons can be obtained from the decay of pions produced with intense proton beams intercepted by suitable targets.

The “Neutrino Factory and Muon Collider Collaboration” [1] investigates high-Z liquid metal jets such as mercury as the target. Based on previous studies at BNL [2] and CERN [3] the MERIT (MERcury Intense Target) experiment was proposed and built as the next milestone by combining a free mercury jet and a focusing/capturing solenoid magnet for the secondary particles, as sketched in FIGURE 1. The main objective was the optical observation of the jet target dispersal by the sudden energy deposition of the beam and the influence of the high magnetic field on the stability of the jet. The CERN PS accelerator complex was chosen as a suitable site. A large number of planned experiments (in excess of 100) had to be carried out in a comparatively short time span during PS beam availability. This dictated the design of an efficient automated cryogenic system capable of rapid recooling the magnet after pulses from a remote control room. This paper describes the setup of the experiment and the cryogenic system with the innovative process adopted. Some experimental results are also presented.

THE MAGNET AND MERCURY SYSTEM

The magnets for the target system of a muon collider or neutrino factory will be superconducting and produce a steady field. To minimize costs a normal-conducting, pulsed copper magnet was designed for the MERIT experiment. Magnet cooling to cryogenic temperatures results in a reduction of the coil resistance allowing the construction of a comparatively moderate-sized magnet for a given power supply. For the sake of simplicity, cooling with slightly pressurized nitrogen boiling at around 80 K was adopted. The solenoid magnet mainly consisted of three nested coils wound from solid, rectangular copper conductor. The 4000-kg magnet was housed in a cryostat with feedthroughs for the cryogen and the current leads. The operation of the solenoid at 80 K allowed a maximum magnetic field of 15 T when excited with a pulsed current of 7200 A

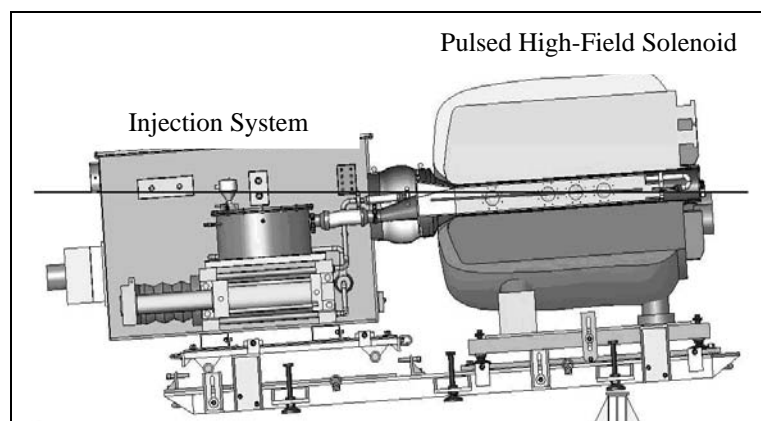

FIGURE 1. The pulsed high field magnet mated with the Hg injection system. The Hg jet intercepts the proton beam within the confines of the magnet.

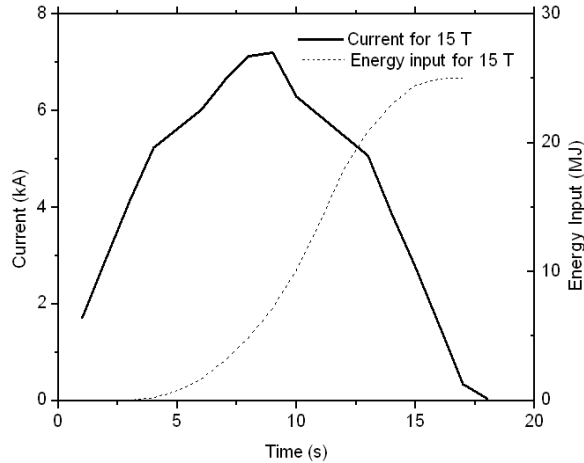

FIGURE 2. A magnet pulse of 15 T by ramping the current up and down. During the current plateau the beam intercepted the Hg jet. Energy deposition reached a maximum of 25 MJ.

at 600 V (4.32 MVA peak power). About 25 MJ of energy were deposited in the magnet due to Joule heating for each pulse to maximum field. The time needed to remove this heat determined the operational cycle time of the system. After each cooldown the magnet cryostat was filled with liquid nitrogen to obtain a uniform temperature of the magnet coils at all levels before the subsequent pulse. FIGURE 2 shows the ramp of the current and the calculated Joule heating. During the short plateau at maximum field the beam was extracted from the PS and intercepted by the mercury jet.

EXPERIMENTAL SET-UP OF THE CRYOGENIC SYSTEM

The cryogenic system was comprised of several units located at different areas which were interconnected by hydraulic links. The magnet and its cryostat were in the experimental tunnel TT2A where the extraction system of the PS collider guided the proton beam to the free-jet mercury target in the bore of the magnet. Two cryogenic lines, one for cooling, filling and emptying with LN₂ and one for the exhaust gas made the link with the distribution valve box (DVB). The DVB connected via a transfer line to the external 6000-litre LN₂ dewar installed on surface at a distance of approximately 50 m with 8 m difference in height. FIGURE 3 shows a simplified layout of the system. The dewar was pressurized to 5 bar permitting the transfer of LN₂ to the DVB. A further unit on the surface consisted of a pressurisation system which either used nitrogen gas from the dewar warmed up to ambient temperature, or from high pressure bottles. The pressurisation system permitted the emptying of the magnet cryostat after cool down and transfer the LN₂ back into the phase separator of the DVB. This was done to reduce the quantity of nitrogen activated by the proton beam, and to limit the pressure rise in the cryostat during a current pulse.

The DVB was the main device for the control of the cryogenic process and served as the interface between the external equipment of the cryogenic system, distributing and controlling the fluid flows from the surface dewar and to and from the magnet cryostat. It comprises several cold and warm control valves and instrumentation – the flow scheme is presented in FIGURE 4. The cryogenic system close to the magnet is called “proximity cryogenics”.

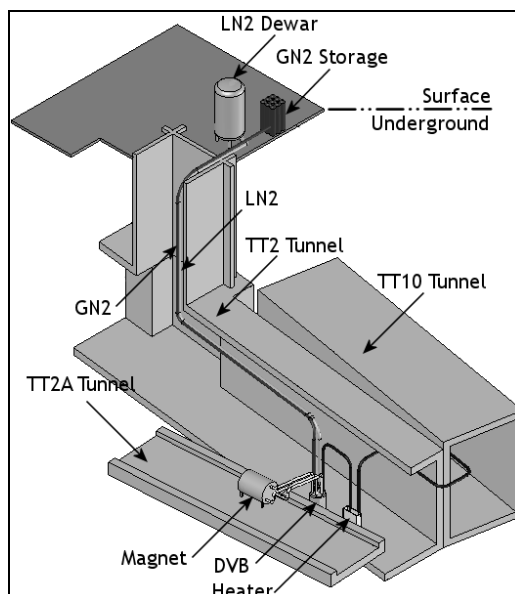

FIGURE 3. Layout of the cryogenic system.

Differential pressure transducers were used to monitor the liquid levels in the magnet cryostat and the DVB phase separator. Nitrogen gas and liquid flow rates were monitored by two venturi flowmeters: one was a standard venturi type measuring the flow rate of the vaporized nitrogen during cooling of the magnet; the second was a special development that operated as “double acting”, permitting measurement of the liquid flow rate in two directions (when the coolant was transferred from the DVB phase separator to the magnet, and, vice-versa, when the magnet cryostat was emptied by pressurisation). This innovative double-acting venturi flow meter was designed at CERN using the guidelines of [8] which were adapted to the concept [9].

The liquid mercury target jet with a peak velocity of 20 m/s was produced by an auxiliary hydraulic pump taking mercury from a vessel to which the jet flow returned. The solenoid and Hg target system were placed in the TT2A area of the CERN PS complex – FIGURE 5. The DVB, the high-speed cameras (used as optical diagnostic system) and all instrumentation cabinets were placed in the TT2 tunnel (adjacent to TT2A), behind a concrete wall which provided radiation shielding. The PLC (Programmable Logic Controller) control unit was also placed in the TT2 tunnel. The complete system supervision was made from a control room on the surface several hundred meters away from the MERIT experiment location.

CRYOGENIC SYSTEM OPERATION PROCEDURE

The CERN Standard for Slow Controls based on a Schneider Electric PLC TLX Premium and a remote PVSS supervision station was used for supervision and control via Ethernet. The flow process logic was designed and programmed for remote control from an operator work station.

Six steps were defined for every cooling cycle: standby mode, cooling of proximity cryogenics, magnet cool down, emptying the magnet cryostat, magnet pulse and recooling. During the standby mode the external LN₂ dewar was left unpressurized and isolated; nitrogen flow to/from the magnet was blocked by valve actuators for reasons of safety. During the cool down of the proximity cryogenics, LN₂ was slowly driven through the

transfer line from the surface dewar to the pressure controlled phase separator. Subsequently slow cool down of the magnet was done with limited flow rate. For the final

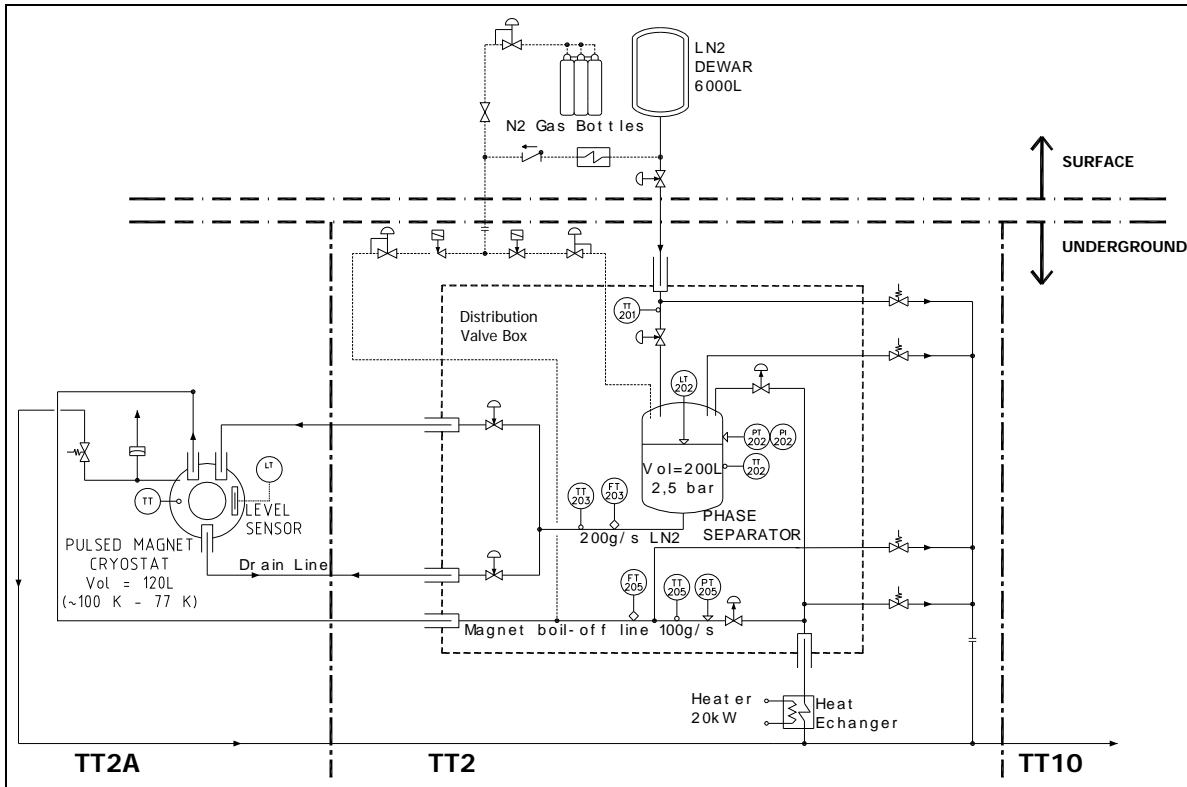

FIGURE 4. MERIT flow scheme.

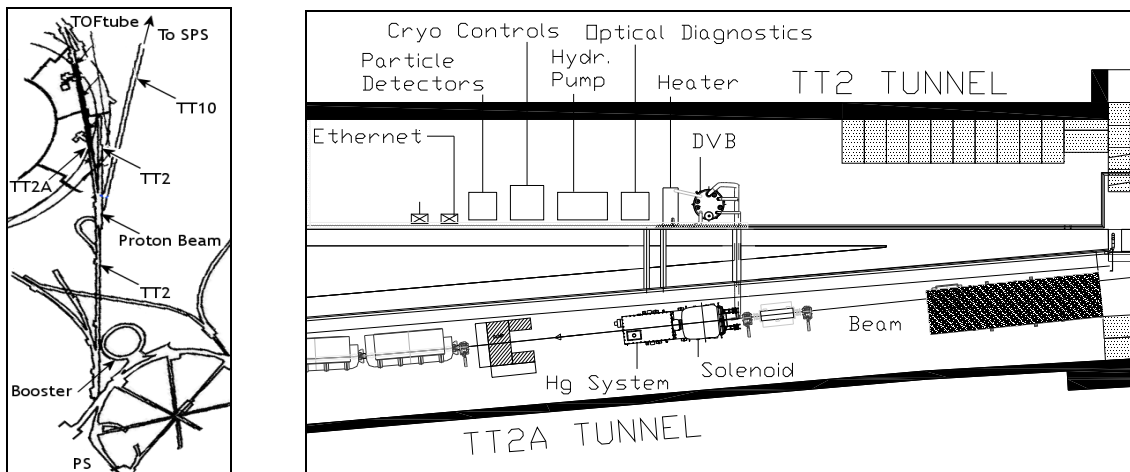

FIGURE 5. (a) CERN PS extraction tunnel complex. (b) Plan of the MERIT layout in the TT2 and TT2A tunnels.

cooling the cryostat was filled such that the full magnet was immersed in liquid nitrogen in order to guarantee a uniform temperature of its three coils at any location. Limiting parameters were, depending on the respective operation, the allowed maximum temperature gradient in the magnet coils of 50 K which had to be respected or the maximum flow of 200 g/s. When the magnet reached uniform temperatures a fast emptying process started in pressurizing the magnet cryostat to several bars with the ambient temperature nitrogen gas pressurization system. The liquid was pushed back against gravity to the phase separator of the DVB for intermediate storage and later re-use for the

recooling after the magnet ramp. Once the magnet cryostat was empty, the mercury hydraulic system was started to produce the jet and the magnet was ramped. During the plateau of the maximum magnetic field lasting 1 second the stored beam of the PS accelerator was extracted and intercepted with the mercury target. The electrical pulse warmed up the cold magnet. The temperature rise depended on the dissipated energy which was in relation to the maximum current applied. Eventually the magnet needed to be re-cooled for subsequent cycles.

Safety

All vapor generated during the cooling and recooling of the magnet, as well as during transfer and pressure control, was heated up to ambient temperature by a an electrical water heater of 20 kW and transferred via pipe run to n tunnel called “TT10” where activated gases were filtered and treated.

An ODH (Oxygen Deficiency Hazards) warning system was installed and linked to the process control of the cryogenic system. In case of accidental loss of cryogen the supply of liquid nitrogen from the dewar to the underground area would be interrupted by closing the supply valve. Further, online cameras for supervision of the underground area were used.

Access of personnel in the underground area was strictly controlled. During the test campaigns no undesired or insecure situations for personnel occurred.

During the test campaign three times failures of the PLC control unit occurred. Investigations lead to the conclusion that this happened at the moment of interception of high energy beams in the target. The PLC CPU were hit by high energy hadrons which were upset and stopped functioning. This effect is referred to as Single Event Effect (SEE). Each time the PLC had to be replaced. The target was surrounded by the 4 ton magnet and, the thickness of the wall between the experimental area and the PLC location we estimate to 2 to 3 meters.

CRYOGENIC SYSTEM RESULTS

Energy Input

A typical magnet-current-pulse profile had a ramp-up time of 9 seconds, a flat-top of 1 second and a ramp-down time of 5 seconds. The solenoid field levels during individual experiments were fixed to 5, 7, 10 or 15 T. In total, 183 current pulses were performed

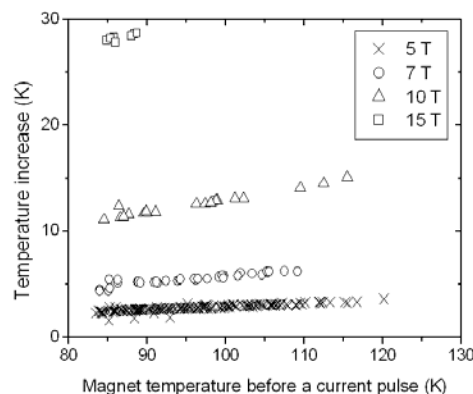

FIGURE 6. Magnet temperature increase for various current pulses as a function of the initial magnet temperature.

during the experiment run, most of them at medium magnetic field levels (119 pulses at 5 T and 35 pulses at 7 T), and 7 at maximum 15 T field. This was to investigate the influence of the field intensity on the dispersion of the mercury jet when “hit” by the intense proton particle beam.

Temperature Increase During a Magnet Pulse

The maximum allowed temperature of the magnet, before a recooling was required, was fixed to approximately 130 K. A magnet pulse to 15 T caused a temperature rise of 30 K, while a pulse to 10 T caused a rise of only 11 to 15 K, depending on the initial temperature of the magnet. Therefore, several pulses at lower field levels could be carried out before the magnet was recooled to 80 K. This procedure permitted a larger number of magnet pulses during the 3-week experimental campaign - FIGURE 6 and TABLE 1.

TABLE 1. Magnet temperature increase and LN₂ consumption as a function of the energy input.

Magnetic Field (T)	Energy Input (MJ)	Temperature Increase (K)	Allowed number of pulses below 130 K	LN2 Consumption	
				Theoretical (l)	Experimental (l)
5	3	3-4	9	19	27
7	5	5-6	5	31	54
10	12	11-1	2	75	119
15	25	28-29	1	156	258

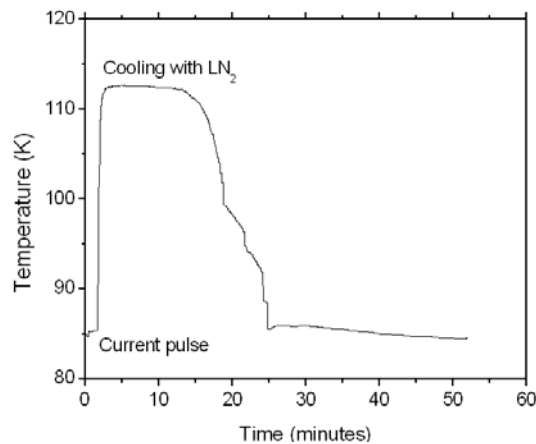

FIGURE 7. Magnet cryostat average temperature evolution for a cooling cycle after a 15 T pulse.

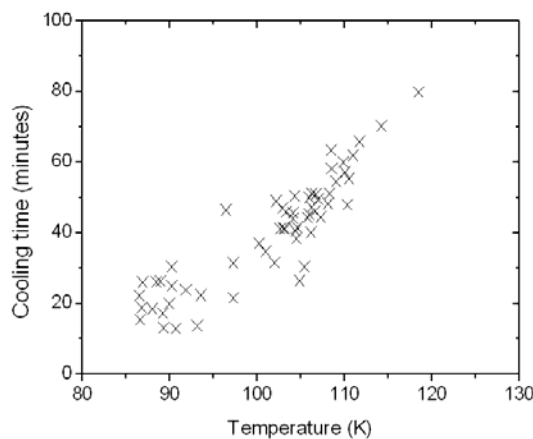

FIGURE 8. Cooling cycle time as a function of the magnet temperature.

Cooling Cycle

A cool down from 130 K to 80 K took about 40 minutes - FIGURE 7. FIGURE 8 shows the cooling time as function of the magnet temperature after the magnet pulses for the 60 cooling cycles performed during the MERIT test run at different magnet temperatures. When the magnet reached its nominal temperature of 80 K the LN₂ was removed from the magnet cryostat to the phase separator. This operation took an average of 4.5 minutes to be executed. The total cooling cycle time for the magnet was about 45 minutes. The theoretical LN₂ consumption for the magnet cooling was 6.2 l for each MJ of deposited Joule heating - TABLE 1. During the experimental run about 10 l/MJ were necessary, indicating an overall efficiency of the system of about 70%.

CONCLUSIONS

The MERIT experiment has been successfully completed. The principle of a free mercury jet target inside a strong magnet field as proposed for future accelerator facilities has been validated for pulsed beam powers exceeding 4 MW. The fully automated cryogenic system designed proved to satisfy the requirements for fast recooling cycles of the Joule heating of the normal conducting magnet. This permitted almost 200 magnet pulses during the three weeks of the 2007 experimental campaign.

REFERENCES

1. *The Neutrino Factory and Muon Collider Collaboration*, <http://www.cap.bnl.gov/mumu/>
2. Kirk, H. G., McDonald, K. T., et al. *Studies of a Target System for a 4-MW, 24-GeV Proton Beam*, CERN-INT-2004-016, 2004
3. Fabich, A., *High Power Proton Beam Shocks and Magnetodynamics in a Mercury Jet Target for a Neutrino Factory*, Ph.D.Thesis, Technischen Universitat Wien, 2002
4. Titus, P. H., *Design Report – MERIT BNL – E951 15T Pulsed Magnet for Mercury Target Development*, MIT Plasma Science and Fusion Centre, 2006
5. *Design, Operations, and Safety Report for the MERIT Target System, Report NO. 203-HJT-9010 Rev.0 (Draft A5)*, 2006
6. *Technical Specification for the fabrication of a Cryogenic Valve Box for liquid nitrogen distribution* EDMS document No.: 695878, CERN Internal Report
7. Haug, F., Santos Silva, P., Pereira H., *MERIT - On Surface Cryogenic System Commissioning – Preliminary Test Results*, CERN Internal Report, 2007
8. *International Standard 5167 (Measurement of fluid flow by means of pressure differential devices inserted in circular cross-section conduits running full)*
9. Haug, F., Pereira H., Santos Silva P., *Venturi Flowmeter Specifications*, CERN Internal Report, 2006