

## **EXTENDING THE APPLICATION OF HTS IN PARTICLE ACCELERATORS**

A. Ballarino, K.-H. Meß and T. Taylor

The year-to-year improvements in the characteristics of high temperature superconductor (HTS) materials encourage periodic reappraisal of their applicability for use in accelerators. With the successful large-scale application of HTS technology for the current leads of the Large Hadron Collider at CERN, this tendency is accentuated, and the new materials are now starting to receive more serious attention as candidates for other accelerator-related applications. The medium- to long-term goal will be to use the materials for magnets, but their characteristics are totally different from those of classical multi-filamentary Nb-Ti material and the transition will be difficult. In particular it seems likely to be inappropriate to carry over the presently conventional coil geometries and conductor excitation levels. A roadmap is proposed for R&D that will lead progressively to achieving the ultimate goal through consolidation of the necessary technology via intermediate steps, and progressive accumulation of successful applications.

CERN, Accelerator Technology Department, Geneva, Switzerland

Presented at the 8th European Conference on Applied Superconductivity (EUCAS'07)  
16-20 September 2007, Brussels, Belgium



# Extending the application of HTS in particle accelerators

**Amalia Ballarino, Karl Hubert Meß and Thomas Taylor**

CERN, European Organization for Nuclear Research, Geneva, CH

E-mail: Amalia.Ballarino@cern.ch

**Abstract.** The year-to-year improvements in the characteristics of high temperature superconductor (HTS) materials encourage periodic reappraisal of their applicability for use in accelerators. With the successful large-scale application of HTS technology for the current leads of the Large Hadron Collider at CERN, this tendency is accentuated, and the new materials are now starting to receive more serious attention as candidates for other accelerator-related applications. The medium- to long-term goal will be to use the materials for magnets, but their characteristics are totally different from those of classical multi-filamentary Nb-Ti material and the transition will be difficult. In particular it seems likely to be inappropriate to carry over the presently conventional coil geometries and conductor excitation levels. A roadmap is proposed for R&D that will lead progressively to achieving the ultimate goal through consolidation of the necessary technology via intermediate steps, and progressive accumulation of successful applications.

## 1. Introduction

In view of the continuous progress made on high temperature superconductors (HTS), it is confidently expected that these materials will play an increasing role in particle accelerator technology.

Over a thousand HTS current leads, with a total capacity of over 3 MA, have been designed, manufactured, and tested, and are now installed at the Large Hadron Collider (LHC) to conduct the current from room temperature down to the liquid helium environment of the LHC superconducting magnets [1]. As a result of this, the use of HTS is today considered mature technology for leads feeding cryo-magnets. Thanks to the steady improvement of conductor performance, and the appearance of potentially less costly materials, it is considered to extend the application of this promising new technology to other components of advanced particle accelerators. Based on the knowledge acquired through the experience of the current lead project, it is now proposed to apply the same technique of thorough engineering to incorporating HTS technology into those components that can benefit the most from the unique characteristics of these materials, and where their use may allow a modification to the layout. One application is the electrical connection of strings of superconducting magnets and their connection to the current leads that are at present accomplished with Nb-Ti superconducting wire or cable, stabilized with copper or aluminium. It is essential to keep these conductors below about 6 K, which is achieved efficiently by operating them in either liquid or supercritical helium. In certain locations it can be difficult to guarantee that interconnects are sufficiently cold, and it is interesting to consider the use of HTS material. Other examples are devices such as switches, and magnets situated in particularly hostile environments. In the longer term it can be confidently foreseen that some of the materials will be suitable for building very high field magnets, producing 20 T or more, levels of field that are impossible to achieve with classical low

temperature superconductors (LTS). Our preferred approach is to progress to this final goal by stages, consolidating the technology and engineering for a sequence of useful intermediate applications, and collaborating with the conductor manufacturers to develop materials that are suitably optimized. This approach calls for intimate knowledge concerning the choice of materials, and experience in the optimization of designs that takes into account the material constraints. Examples are given of how this technology could be usefully applied to systems being studied for the consolidation and upgrade of the LHC.

## 2. Conductors

Remarkable progress is being made year-to-year in the long-length fabrication of HTS. Developments aim to enhance the wire's electrical and mechanical performance, to manufacture long lengths of engineered material with reproducible and uniform properties, and to establish processes that reduce the manufacturing cost of the conductor. The Bi-2212, Bi-2223, Y-123, and MgB<sub>2</sub> tapes and wires have all achieved a level of performance that makes them suitable, or even preferable to low temperature superconductors, for some specific applications.

Bi-2212/Ag conductors are produced in the form of wire of about 0.8 mm diameter with critical current in self-field (s.f.) above 500 A at 4.2 K, and long-length Rutherford cables with a current capability at 4.2 K of up to 12000 A in self-field and about 5000 A at 6 T have been manufactured successfully [2]. For these Bi-2212/Ag cables, the heat treatment at high temperature (~ 895 °C) is performed after cabling, which implies the use of a wind-and-react technology during assembly of the electrical devices.

Long lengths of homogeneous Bi-2223/Ag tape with critical current above 150 A (77 K, s.f.) are produced [3], with typical mechanical properties including minimum bending radius of about 50 mm and tensile strength at room temperature of 100 to 170 MPa.

An enormous effort is being put into the manufacture of second generation Y-123 conductors, and substantial progress has been made. Lengths of tape of up to 100 m have been produced with critical current above 300 A/cm-width (77 K, s.f.), approaching the typical electrical performance of the 4 mm wide Bi-2223/Ag tape, and a 600 m long conductor with good current uniformity (~ 6.4 %) and minimum critical current of 173 A/cm-width has been manufactured [4], marking an important milestone in terms of long length production. Ongoing improvements and optimization in the tape manufacturing processes, aiming to enhance the critical current by increasing the thickness of the superconducting layer (presently only about 1 μm) and to reduce the cost of the conductor by achieving higher production speeds and/or employing processes bringing to simplified tape architectures, makes of the Y-123 a promising high-performance and low-cost superconductor.

When used in the vicinity of 4.2 K, Bi-2212/Ag, Bi-2223/Ag, and Y-123 are interesting conductors for applications in very high fields (> 15 T), where the materials exhibit good current retention behavior and performance competes with that of the conventional Nb-Ti and Nb<sub>3</sub>Sn LTS.

Multi-filamentary long-length MgB<sub>2</sub> tape and wire are now becoming available for application to electrical devices [5]. Critical currents above 200 A at 30 K and 300 A at 27.5 K are well established performances in self-field conditions. The small filling factor of the presently available PIT tapes (~ 10 %) leaves room for improvement of the electrical properties. While the conductor has a promising high field performance - an upper critical field H<sub>c2,0K</sub> over 60 T has been achieved in suitably oriented MgB<sub>2</sub> films - further development still has to be made in order to enhance the critical current in strong fields, and the wires produced today are suitable for applications below 5 T. The relatively easy fabrication process and the low cost of raw materials potentially make MgB<sub>2</sub> a low-cost superconductor for low temperature applications (< 30 K).

## 3. Applications

The cryogenic system of an accelerator such as the LHC makes available cold gaseous helium at various temperature levels (5–20 K and 50–75 K) for the cooling of accelerator components (e.g. beam and thermal screens). As a consequence, HTS can be operated at temperatures below that of

liquid nitrogen, bringing the advantage of enhanced electrical properties. Besides the current leads, which after the development for the LHC have become a mature technology for the powering of superconducting systems, other devices required in accelerators could benefit from employing HTS technology. These include feeders, switches, special magnet shielding, and beam instrumentation.

In addition to large-scale applications, specific small-scale applications can be identified. In view of the ongoing successful development of HTS filters made with Y-123 thin films [6], low-loss HTS filters can be designed for incorporation in the front-end electronics of the beam positioning and beam tune monitors of the accelerator. These devices, presently installed in the radiation environment of the accelerator tunnel, operate at a frequency corresponding to the frequency structure of the beam (80 MHz for the LHC machine), and filter the pick-up electrostatic or electromagnetic signals that provide the horizontal and vertical position of the beam all around the ring, and the characteristic frequency of the magnet lattice. The combination of low temperature, low resistance, high selectivity, and radiation resistance properties makes of these filters low-noise and high performance devices that could improve the accuracy of the conventional electronic components.

### *3.1. Current Leads*

The LHC current leads are the first large-scale application of HTS. They transport about 3 MA of current for feeding thousands of electrical circuits operating at currents ranging from 600 A to 13000 A [1]. When the potential of using HTS in current leads was first identified [7], it was not clear which HTS technology would have been the most appropriate. After an R&D activity aiming to characterize different HTS materials incorporated in high-current leads, the choice of the Bi-2223/Ag tape, with 5% wt gold in the matrix, was made. A total length of 31 km of Bi-2223 tape was purchased from two commercial manufacturers (AMSC and EHTS) and incorporated in the current lead devices according to procedures that were developed at CERN. The maximum operating temperature of the HTS is 50 K, and 20 K helium gas is used for the cooling of the resistive part of the lead. Following thorough qualification of the designs through measurements performed on prototypes, more than a thousand HTS leads were manufactured, tested in nominal operating conditions and installed in the LHC tunnel, where they are now undergoing the cool-down and powering tests foreseen in the framework of the hardware commissioning activities.

The use of HTS in current leads offers the potential of saving in the total cost of the refrigeration by reducing the heat load into the cryogenic environment. In the LHC accelerator the reduction of heat load into the 4.5 K liquid helium bath is a factor 10 with respect to conventional self-cooled current leads, and the corresponding saving in total cooling power is about 30 % [1]. In addition, thanks to the reduced cryogenic load it became possible to envisage independent powering of the quadrupole magnets in the matching sections, leading to increased flexibility in the optics.

HTS current leads are now also the natural choice for feeding superconducting systems cooled by cryo-coolers. In this case, the use of HTS conduction-cooled current leads is appropriate for low-current applications ( $< 1$  kA), where the use of HTS is essential in that it enables a significant reduction of the heat load at the lower stages ( $< 20$  K) of the cryo-cooler, where the refrigeration capacity is too limited to absorb the losses of optimized conventional conduction-cooled current leads.

Current leads have been an ideal application of HTS from the early days of the first generation of superconductors. The benefit of the application is such that HTS is preferable to conventional materials, while the mechanical and electrical performances requested of the superconductor are much less demanding than other applications where homogeneity of electrical properties along long lengths, high current capabilities in magnetic fields, and good mechanical properties are key issues of the design. In this way HTS current leads have now become the standard choice for the powering of superconducting systems.

### *3.2. Cables*

The interest of using HTS cables in particle accelerators has already been identified, and it is discussed in detail elsewhere [8]. This applies to the interconnection of string of magnets, connection of

magnets to power converters and/or to current leads, where the replacement of conventional LTS bus or warm cables with HTS offers significant potential benefits.

In the case of LTS conduction-cooled magnets, where the use of LTS bus requires a sophisticated cooling approach to avoid quenches, and of LTS magnets operating in areas where heat losses (e.g. sporadic radiation losses and direct heat load coming from the beam with increasing beam intensities) may become important, the use of HTS offers a significant gain in temperature margin.

In the case of magnets made with HTS coils, an HTS bus is needed.

In the context of a complex accelerator such as the LHC, HTS buses can be used to connect the resistive part of the leads to the magnets, providing flexibility in the location of the cryostats housing the leads. These cryostats, which in the LHC tunnel are in line with the magnets in zones where the space is limited and the radiation environment is severe (i.e. near the high luminosity interaction points), can be removed to alcoves or to underground areas parallel to the main accelerator tunnel, where the power converters are also located. Together with the cryostats, also the sensitive devices associated with the leads (control valves, heating system and related electronics) can be removed to radiation free areas, which can be easily accessed during operation or for maintenance issues. The bulky warm cables presently connecting the power converters to the leads can be taken away from the tunnel and replaced with compact HTS buses joining the bottom end of the resistive part of the lead to the interconnecting bus leading to the magnet cold mass. This implies a major simplification in the architecture of the electrical distribution in the tunnel. The LHC, for instance, has thousands of warm cables individually connected to the leads and pulled and guided from the alcoves to the position in the tunnel where the leads are located.

In the case of the LHC, the need has been identified for (1) replacing existing Nb-Ti links, up to 500 m long and operating in helium at about 5 K, located in the vicinity of the collimators and subjected to intense radiation heating, and (2) connecting displaced feedbox cryostats to the Inner Triplet magnets being studied in the framework of the LHC luminosity upgrade. In both cases, the HTS cable would contain multiple circuits - up to 24 - operating in quasi-DC mode at currents ranging from 600 A to 13000 A.

In view of the low temperature operating range provided by the cold helium gas available in the LHC cryogenic system, MgB<sub>2</sub> as well as first and second generation HTS materials are potential candidates being considered for this application.

### 3.3. *Switches*

An HTS current lead can be optimized in such a way that the top section of its HTS element operates at any temperature between about the inlet temperature of the cooling gas and the critical temperature of the superconductor. The incorporation at the bottom of the resistive part of the lead of an HTS element having switching properties enables the construction of a device associating low-loss transport and switching characteristics. The parallel connection in the same device of a safety lead, a thin resistive lead designed for transporting the current during the short time needed for the discharge of the magnet, brings to a 3-in-1 compact lead that, connected to the negative pole of the power converter, can be used for the protection of the superconducting circuit (see figure 1). The HTS switching element would be normally superconducting, and it would be triggered to its resistive state in case of quench of a magnet. The switching time needed for the protection of the superconducting magnet circuit is of the order of few milliseconds, and the resistance of the switch is imposed by the resistance of the room temperature dump resistor in series with the safety lead. In this case, the HTS switch incorporated in the lead would replace the warm extraction switch presently used for the protection of the superconducting magnet. Both magnetic and thermal activation can be used, since the HTS is made to work near the critical temperature, where the material is sensitive to the magnetic field. The recovery time for this type of application does not need to be fast, since the time of recovery after the quench of a magnet is driven by the recovery of the global system (magnet and cryogenics), and can be of the order of 30 minutes or more.

In the LHC machine, most of the individually powered magnets do not have dump resistors and rely on quench heaters, installed between the insulated coils and the collars, which are powered in case of quench to distribute the resistive length along the LTS winding and avoid overheating. The full stored energy is absorbed by the magnet itself. For these individual magnets, the 3-in-1 lead provides an alternative protection method. In addition, in case of failure of quench heaters after installation of the magnet in the tunnel, the replacement of an HTS lead with the 3-in-1 version would be a solution that may be simpler than accessing the magnet – and probably removing it – for repair.

In the case of the LHC main dipole chain, which contains a series of 154 magnets powered with current up to 13000 A, two HTS leads are connected to the power converter, and two additional HTS leads, located at the end of the arc, are connected to a warm switch based on electro-mechanical breakers [9]. This switch, normally closed, has a parallel warm dump resistor, where the energy is dissipated in case of quench of a magnet. The opening time of the switch is of the order of 25 milliseconds. The two leads used for energy extraction transport the total current in and out of the cold mass during powering. The introduction of an HTS switch, short-circuiting the cold part of these two leads (see figure 1), would bring a simplification of the system by replacing the resistive part of the leads with thin safety leads, only powered for a short time in case of quench of a magnet, eliminating the warm connecting cables, and suppressing the warm circuit breaker.

The use of the 3-in-1 lead for protection can also be applied to fast pulsed magnet circuits, where the high inductive voltage generated during the ramp makes difficult the use of cold diodes for the protection of the magnets.

HTS second generation conductor has been developed for application to fault current limiters, and in view of its high resistance in the normal state, is a good candidate for this application [10], as well as bulk  $MgB_2$ , which can be engineered for incorporation in a current lead device.

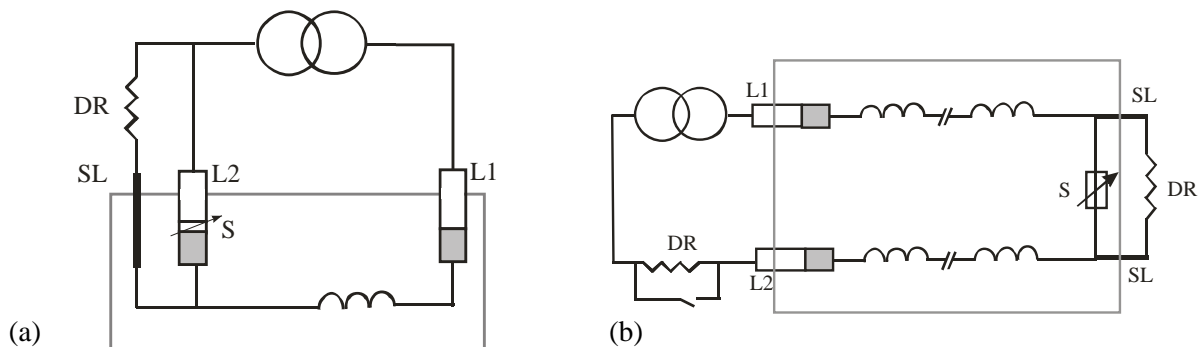

**Figure 1.** (a) Powering with a 3-in-1 lead, (b) Energy extraction with HTS switch (L1 and L2 = HTS leads, DR = Dump resistor, SL = Safety lead, S = HTS switch).

### 3.4. Magnets

The ultimate application of HTS in particle accelerators is for the coils of magnets. The brittle materials are more akin to A15 (e.g.  $Nb_3Sn$ ) than conventional Nb-Ti low temperature superconductors, being brittle once reacted. Their other properties, however, already make them attractive for certain specific applications, such as in places where the windings risk being vulnerable to heating due to radiation, and this in particular for the coils of magnets that can be superferric [10]. A number of demonstration HTS magnets have also been built and tested for applications other than particle accelerators, such as MRI and energy storage [12], as well as insert windings for high-field magnets [13]. As the materials improve and experience is gained with their use, the field of application will extend to both the economic replacement of resistive coils in iron-dominated magnets, and the provision of higher fields than those achievable with LTS material.

Magnets require long lengths of conductor that may be wound before (wind-and-react), or after (react-and-wind) the high temperature reaction required to render the conductor superconducting. Most of the magnets built to date using HTS material are of the react-and-wind type, using tape

material. Some model high-current accelerator-type magnets have been designed and built using cabled Bi-2212 that was reacted after winding [14]. For the relatively large-scale application to particle accelerators, the HTS material needs to be accepted by the community as being both reliable and having either demonstrable economic benefits or qualities that can not be achieved using a more classical approach. There is still progress to be made with the materials before they achieve the status of being the standard commodity that can satisfy such requirements – progress that requires a collaborative understanding between accelerator scientists and engineers and the producers of the materials to target the important parameters. In order to nurture this collaboration and to gain acceptance in the accelerator community, it is necessary to select specific applications and press ahead with careful engineering and integration into the big facilities. With this in mind we are investigating the possible advantages of two types of magnet that could be made using racetrack coils of presently available material, (1) iron-free dipole and/or quadrupole magnets for installation on the beam-line within the experiments to enhance the efficiency of the final focusing system, and (2) superferic magnets for beam orbit correction in regions of high radiation, such as near the interaction points or the beam collimation regions. The flexibility of the LHC cryogenic system, which can supply gaseous helium at 5 to 20 K, besides liquid, and gas at about 50 K, is an important enabling factor.

An aspect of the engineering of high-performance HTS magnet systems for accelerators that should not be overlooked is the quench protection, as the behaviour of a quenching HTS magnet is not the same as that of an LTS magnet. While the magnet will need to be protected against a full quench, by correct choice of the level at which the quench is detected, a quench can be reversed (with consequent reduction of thermal stresses) by extracting the energy from the magnet while the superconductor remains in the flux-flow regime. This calls for detecting an integrated signal at a few millivolts threshold, and this has been shown to be feasible in the accelerator environment [15].

#### 4. Conclusion

Medium-term applications of HTS to particle accelerators have been identified, and a roadmap is proposed for a R&D activity that will enable the consolidation of the necessary technology via intermediate steps and progressive accumulation of robust engineering solutions. For long-term applications, in view of the continued rapid improvement of the conductor performance, it is expected that HTS material will play an increasing role in the accelerator technology field.

#### References

- [1] Ballarino A 2002 *IEEE Trans. Appl. Supercond.* **12** 1275-80
- [2] Gupta R *et al.* 2004 *IEEE Trans. Appl. Supercond.* **14** 1198-201
- [3] Ayai N *et al.* 2006 *Journal of Physics* **43** 47-5
- [4] SuperPower Inc. 2007 at <http://www.superpower-inc.com/pdf/2G+highlights+0607.pdf>
- [5] Braccini V, Nardelli D, Penco R and Grasso G 2007 *Physica C* **456** 209-17
- [6] Malozemoff A, Mannhart J and Scalapino D 2005 *Phys. Today* 41-7
- [7] Ballarino A and Ijspeert A 1994 *Adv. Cryogenic Eng.* **39** 1139-42
- [8] Ballarino A, Meß K H and Taylor T 2007 *Proc. Int. Conf. MT-20*
- [9] Dahlerup-Petersen K *et al.* 2001 *IEEE Int. Pulsed Power Conf.* **2** 1473-76
- [10] March S A, Ballarino A, Beduz C, Meß K H and Yang Y 2007 *Presented at EUCAS'07*
- [11] McMahon R *et al.* 2004 *IEEE Trans. Appl. Supercond.* **14** 608-11
- [12] Musenich R *et al.* 2005 *IEEE Trans. Appl. Supercond.* **15** 1452-56
- [13] Markiewicz W, Miller J, Schwartz J, Trociewitz U and Weijers H 2006 *IEEE Trans. Appl. Supercond.* **16** 1523-26
- [14] Gupta R *et al.* 2004 *IEEE Trans. Appl. Supercond.* **14** 1066-69
- [15] Denz R 2006 *IEEE Trans. Appl. Supercond.* **16** 1725-28