

DEVELOPMENT OF L-BAND HIGH-POWER RF SOURCE FOR THE JAPANESE HADRON PROJECT PROTON LINEAR ACCELERATOR

MASAAKI ONO, SHOZO ANAMI, HIROBUMI HANAKI, TADASHI KUBO,
CHIKASHI KUBOTA, KIKUO KUDO, EIICHI TAKASAKI, TATERU TAKENAKA,
HITOSHI BABA and MOTOHIRO KIHARA
National Laboratory for High Energy Physics(KEK)
1-1 Oho, Tsukuba-shi, Ibaraki-ken, 305 Japan

Abstract A high-power and high-duty RF source for an intense proton linear accelerator of the Japanese Hadron Project (JHP) is under development at KEK. The construction of a long pulse modulator and a pulse transformer designed to produce pulses with a 400 μ sec pulse width and a maximum 140 kV pulse voltage was successfully completed. Test operations of a L-band klystron (1.296 GHz) planned to be used at the high- β structure of the linac are also accomplished, producing a 5MW peak RF power at a 400 μ sec pulse duration. Feasibility of the L-band RF source of a 6 MW peak power with a 600 μ sec pulse duration will be discussed.

INTRODUCTION

In the present design of the 1-GeV proton linac for the JHP^{1,2}, 36 L-band klystrons are required as the high power RF source for the high- β accelerating structure. In order to achieve a stable accelerating field in the cavity for a 600 μ sec pulse duration, a feedback system is proposed³ to compensate beam loading; the output power of the klystron will be modulated by a drive power. In this scheme, the klystrons must be operated at unsaturated state. Another crucial point to consider is reliability of the operation for such a large number of klystron system. Therefore, every components of a prototype test station are designed to meet the requirement for producing a 6MW peak power, even though a nominal peak power is 4MW at the proposed linac. The line type modulator was constructed⁴ at KEK for the test station to test the RF power generation with such the long pulse duration. After the initial operation of the modulator with 200 μ sec of pulse length and maximum 140 kV of cathode voltage, the pulse width was doubled by extending a PFN section of the modulator. Fairly well operation of the klystron was achieved up to a maximum 5MW peak power with almost 400 μ sec of pulse duration at a cathode voltage of 130 kV. An accumulation of the experiences of such the long pulse operation will be very essential to reach our final goal.

MODULATOR AND PULSE TRANSFORMER

The expected 6MW output power klystron would need 140 kV and 105 A pulses where the 40% conversion efficiency and 2×10^{-6} beam perveance are estimated from currently available pulsed klystrons. The maximum pulse voltage of the modulator is chosen as 20 kV for assurance of a stable operation of thyratrons which are used as a switching device of the modulator. Consequently, a 7:1 step up ratio is required for a pulse transformer. The details of the transformer are discussed in the reference 5.

As shown in Fig. 1, the modulator consists of a high voltage DC power supply, a charging circuit, the

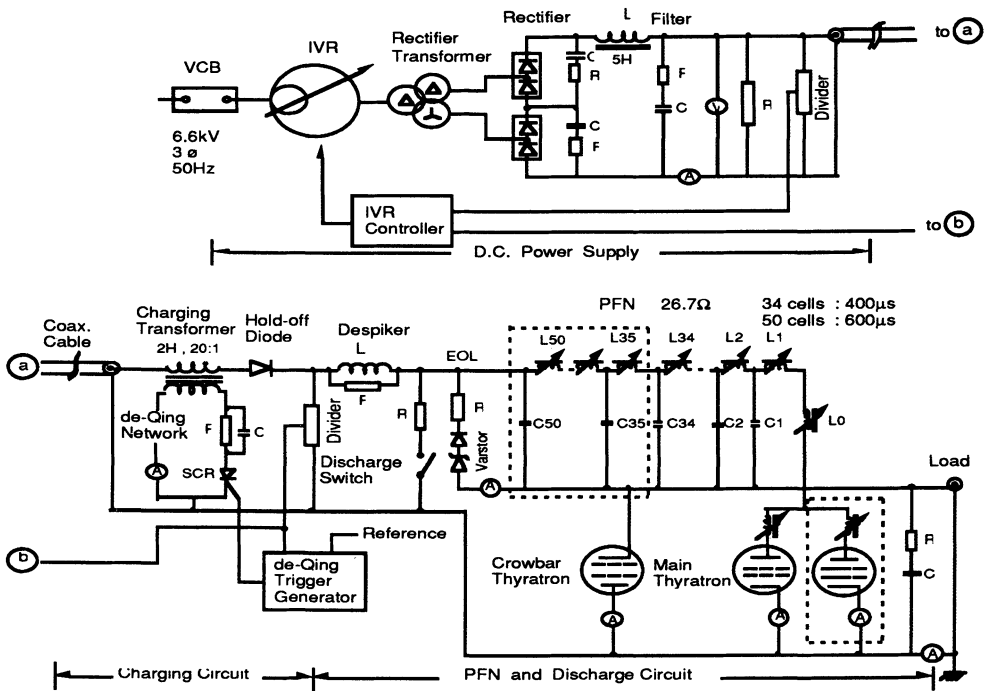

Figure 1 Schematic circuit of the prototype modulator.
(Dashed boxes show a possible future extension).

PFN and thyatron switching devices. The present PFN consists of 34 cells which correspond to a 400 μsec pulse width. At the final objective, 50 cells will be installed to generate 600 μsec pulses. The crowbar thyatron is also installed not only for a protection of the klystron but also for the stable operation of the main thyatron. In the high duty modulator as in our case, it is suspected that the main thyatron will not always cease its fire at a pulse-end period for a wide range impedance of the klystron load. Because an amount of charging up voltage at the pulse-end timing is proportional to a square of the duty. (Notice; Once the hold off diode becomes turned on, the charging up current flow into the PFN continuously, irrelevant to the conduction of the main thyatron.) And because, at low rating power, a positive mismatch of the klystron load may occur and a reflected positive voltage may be applied to the anode of the main thyatron for more than twice the pulse width. The crowbar thyatron triggered at the pulse-end timing always shorten the positive voltage reflection, then it ceases the main thyatron conduction. This pulse-end triggered conduction current of the crowbar is not so heavy (both peak current and pulse duration), therefore we expect much stable operation of this tube compared to the main thyatron. The klystron protection is another function of the crowbar. However, it is expected that an energy dissipation at the klystron is not so much even when an arcing is happened inside of it because almost all of the supplied pulsed energy (stored energy in the PFN) is reflected at the shortened load and is finally dissipated at the modulator. The estimated energy dissipation at the klystron is about 10 joules for 600 μsec duration if the arcing voltage across the klystron gun is the order of 100 V and the current is around 180 A. (Owing to the characteristic impedance of the PFN, the current is restricted less

than the twice the nominal current, even if the load is shortened). This means that not so much a fast triggering system ($< 1\mu\text{sec}$) is required for the klystron protection. The basic parameters of the modulator are summarized in Table 1. More details are discussed in the reference 4.

TABLE I Basic Parameters.
(* indicate at 600 μsec pulse width).

(1) Modulator Output	
Peak Power	15 MW ; 20 kV x 750 A
Pulse Width	400 μsec , (* 600 μsec)
Pulse Rise Time	$< 25 \mu\text{sec}$
Pulse Repetition Rate	50 pps
Average Power	300 kW , (* 450 kW)
(2) Pulse Transformer	
Step-up Ratio	7 : 1
(3) PFN parameter	
Cell Number	34 , (*50)
Impedance	26.7 Ω
Charging Voltage	40 kV
Flat top ripple	$< 0.5 \%$
Inductance/cell	160 μH
Capacitance/cell	0.22 μF

KLYSTRON AND DUMMY LOAD

A high power pulsed klystron (Thomson, TH2104A) which can produce a peak power of more than 5MW at a 600 μsec pulse duration was installed at the test station to do high power test of the modulator, the pulse transformer, the klystron itself and other components. The TH2104A tube, according to the factory data, can produce a 7.3MW peak power for a reduced pulse duration (270 μsec) when the 140 kV and 108 A beam power is supplied. The produced RF power is directed to a dummy load (Varian, L650BA4) guided by a WR-650 waveguide system which is filled with a SF6 gas at 1.5 bar absolute pressure for preventing breakdown of RF windows of the klystron and dummy load. The klystron was operated at 1298 MHz and 400 μsec of pulse duration. Typical operational parameters of the klystron are described in the next section. The waveguide type water dummy load with a beryllia ceramic window has capability of a 5MW peak and 300 kW average power. The limitation to the energy per pulse is also exist; the maker guarantee up to 2000 joules/pulse which correspond to a 5MW peak and 400 μsec duration. A factory data sheet shows a small VSWR (< 1.1) for a water temperature range between 15°C and 30°C. More powerful dummy load system, for example parallel use of it, is needed at the 6MW peak and 600 μsec duration power test.

HIGH POWER TEST

The output power of the klystron is calibrated by a calorimetric measurement of the dissipated power at the dummy load. The power measured by a directional coupler mounted on the waveguide is consistent with the calorimetric measurement within 5% discrepancy. Neither a dissipation power at the waveguide nor a escape of the heat to atmosphere are taking into account in the calorimetric measurement, because these corrections are negligible small compared to the uncertainty of the temperature difference and water flow rate

measurements. A calculated dissipation power at the waveguide is around 144W/m for 5MW peak and 3% duty operation for an aluminum waveguide and a temperature rise at the surface of the waveguide is estimated around 30°C at 30°C atmosphere. The measured temperature rise of the surface is quite consistent with the calculated one, even though this comparison has been done at low duty (0.3%) operation with 5MW peak power. In any case, a lowering the temperature rise or cooling of the waveguide may be required at the higher duty operation. In the calorimetric measurement, the pulse width of the drive power is reduced to 300 μ sec to produce an almost rectangular shape output power as shown in Fig. 2. Other quantities such as cathode voltage, beam current, reflection power and phase fluctuation are also shown as indicated in the Fig. 2.

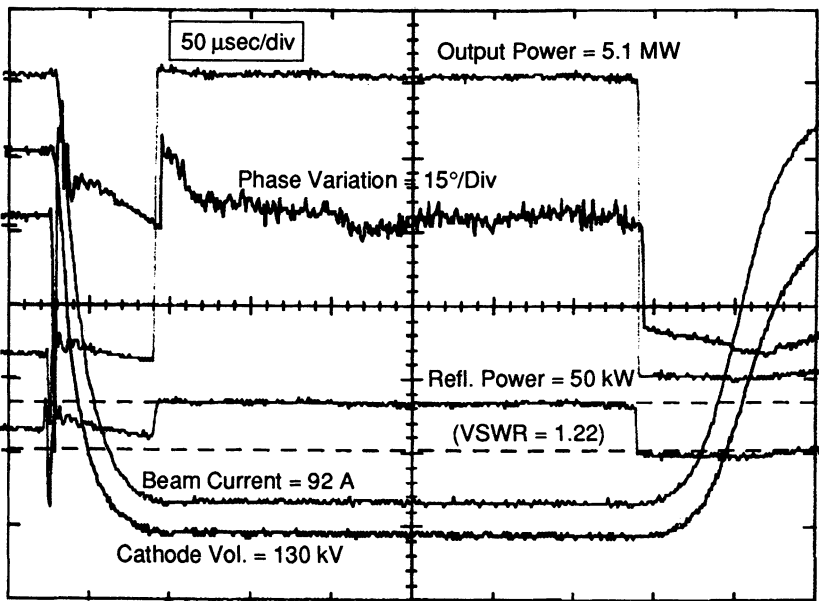

FIGURE 2 Typical pulse shape data at 5MW output.

The rise time of the cathode voltage is around 28 μ sec at this moment. A small dip near the middle of the pulse top can be seen in the phase measurement even though no clear dip can be observed in the cathode voltage at this measuring scale. We don't yet finish the final adjustment of the inductance of the PFN for flattening the pulse top and shortening the rise time. Figure 3 shows the phase variation as a function of the cathode voltage (V_k). Where the phase difference is measured between the drive and output powers. Using the slope of $\Delta\phi = 8.4^\circ/\text{kV}$ and the phase dip of Fig. 2, the cathode voltage variation is estimated to be the order of 0.2%. The output versus drive powers at several operation points are shown in Fig. 4. Unfortunately, owing to a power limitation of the present driver amplifier, the saturation is not clearly observed even though the factory data show the saturation at 120W drive power for 5.4MW peak power generation. Typical operation parameters at 130 kV are shown in Table 2. The measured gain and the efficiency are also a little less than the factory values as shown in Table 2. We don't yet resolve these discrepancy.

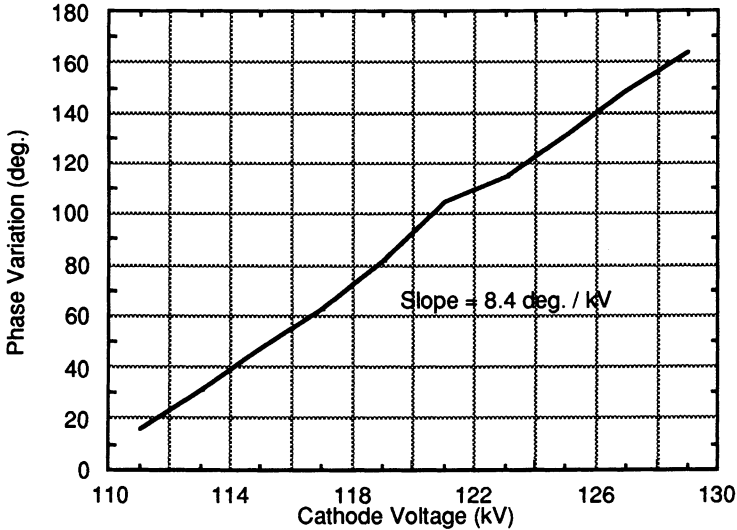

FIGURE 3 Phase variation vs. cathode voltage.

TABLE II Typical operation parameters.
(3rd column show the factory data).

Peak Power	5.2 MW	5.4 MW
Pulse Duration	300 μ sec	600 μ sec
Cathode Voltage	130 kV	125 kV
Beam Current	92.4 A	91 A
μ Perveance	1.97	2.06
Efficiency	43.3 %	47.5%
Gain	44.2 dB	46.5 dB
Drive Power	200 W	120 W

DISCUSSION

The prototype L-band test station can now generate a 5MW peak power for around 400 μ sec of pulse duration. The extension of the pulse width of the modulator to 600 μ sec is feasible as we did at the pulse width widening from 200 μ sec to 400 μ sec. However, we expect severe operational situation of the main thyatron at the higher duty operation even though the thyatron is replaced⁴ to a currently most powerful thyatron (ITT F-259; 50 kV, 10 kA peak and 25 A average) from two ITT F-175 thytrons connected in parallel. Actually, even after the replacement, we observed a less stable operation of the modulator when the repetition rate is increased at the present 400 μ sec pulse width. In that case, a delicate adjustment of the operational parameters of the thyatron is required; for example, fine tuning of the reservoir voltage. The parallel use of the two F-259 thytrons as the main switching device as shown in Fig. 1 will be one solution to withstand the higher duty operation. At the initial phase of this modulator, where the ITT F-175 thytrons were used⁴, we have already tried parallel operation of the thyatron and we feel confident of such parallel operation. For the crowbar thyatron, the ITT F-175 is still used, because of a low duty operation for positive reflection short

and very low frequency of the true crowbar work. We are also seeking another possibility to use solid state devices such as a SCR and GTO instead of tubes. Needless to say, the feasibility of the high duty and high power klystron is the most essential point to attain our final objective. As stated before, the TH2104A tube already produce 7MW for 270 μ sec pulse duration. We should check the actual state of the art for present available klystrons; how far is it from our goal, or is it already reached there ?

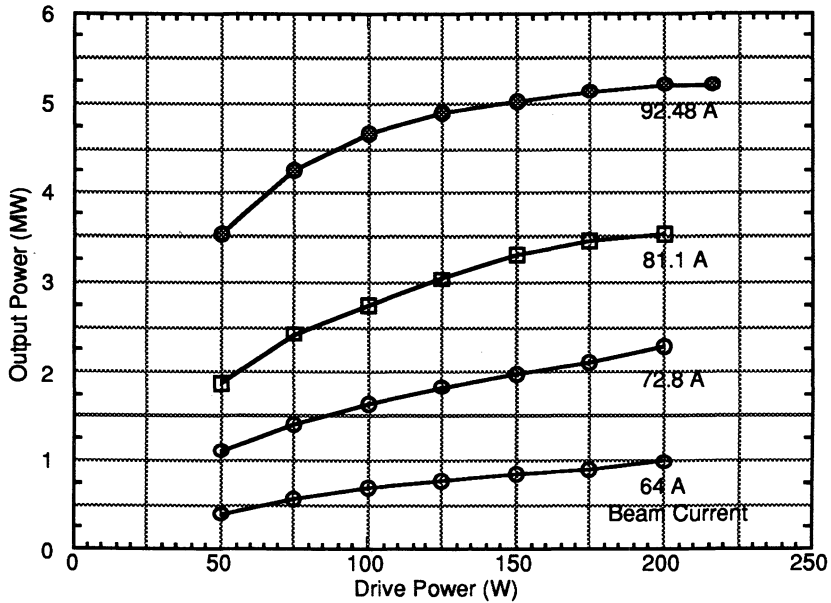

FIGURE 4 Output power vs. Drive power.

REFERENCES

1. Y. Yamazaki et al., Proceeding of the Advanced Hadron Facility Accelerator Design Workshop, LA-11432-C, 80 (1988).
2. Y. Yamazaki et al., "The 1 GeV Proton Linac for the Japanese Hadron Facility", Proc. 1988 Linear Accelerator Conf., Williamsburg, VA, USA.
3. H. Hanaki et al., "Control of an RF Amplifier for Japanese Hadron Facility", Proc. 1988 Linear Accelerator Conf., Williamsburg, VA, USA.
4. S. Anami et al., "Design and Construction of a Long-Pulse Modulator", Proc. 1989 Particle Acceleration Conf., Chicago, IL, USA.
5. Ta. Kubo et al., "Design and Construction of a Pulse Transformer for a Long Pulse klystron", Contribution paper to this Conf.